

# LabVIEW Driver: "Radwag Balances & Scales"

DEVICES:  
DEVICES USING SI PROTOCOL

USER MANUAL

ITKU-96-02-12-16-EN



**RADWAG BALANCES AND SCALES**  
ADVANCED WEIGHING TECHNOLOGIES

## Information on document

Project name:

LabVIEW "Radwag Balances & Scales" Driver

## Versions management

Version	Date	Description
1.0.0	2015	<ul style="list-style-type: none"><li>● RS-232 communication exclusively</li><li>● communication protocol based on R series commands</li><li>● taring, setting tare</li><li>● zeroing</li><li>● collection of stable or unstable measurement expressed in user or calibration unit</li><li>● autocalibration</li><li>● setting mass of a single part (parts counting)</li><li>● keypad lock</li><li>● mass thresholds configuration</li></ul>
2.0.0	02.12.2016	<ul style="list-style-type: none"><li>● adding TCP/IP communication</li><li>● future supporting of GPIB.VXI,GBIP-VXI, PXI, USB, FireWire communication</li><li>● optimization and advanced operation of communication buffer</li><li>● attempt to re-establish connection when broken</li><li>● creating the following document</li></ul>

## Table OF CONTENTS

<b>1. INTRODUCTION.....</b>	<b>3</b>
<b>2. REQUIRED SOFTWARE.....</b>	<b>3</b>
<b>3. “Radwag Balances &amp; Scales” DRIVER INSTALLATION.....</b>	<b>3</b>
<b>4. “Radwag Balances &amp; Scales” DRIVER OPERATION.....</b>	<b>4</b>
<b>5. CONNECTING WITH RADWAG DEVICES.....</b>	<b>4</b>
5.1. Defining connection using NI-VISA driver.....	4
5.2. Defining Connection by Defining ConnectionString Value.....	9
5.3. Remarks on Initiating and Terminating the Connection.....	9

## 1. INTRODUCTION

LabVIEW “Radwag Balances & Scales” driver enables operating Radwag balances and scales in LabVIEW environment. This driver is written in LabVIEW environment without using external libraries. It is available on each platform on which LabVIEW environment is installed and configured. The driver implements basic commands of SI protocol.

## 2. REQUIRED SOFTWARE

- [LabVIEW 2016](#) graphic development environment or newer.
- [NI-VISA 16.0](#) LabVIEW driver or later.

## 3. “Radwag Balances & Scales” DRIVER INSTALLATION

.zip archive includes “Radwag Balances & Scales” driver. Unpack it to `instr.lib` subdirectory of LabVIEW environment installation directory.

## 4. “Radwag Balances & Scales” DRIVER OPERATION

On driver installation all available controls are in Function palette available from Block Diagram window. Available controls are to be found in *Instrument I/O* section, *Radwag balances and scales* subsection.

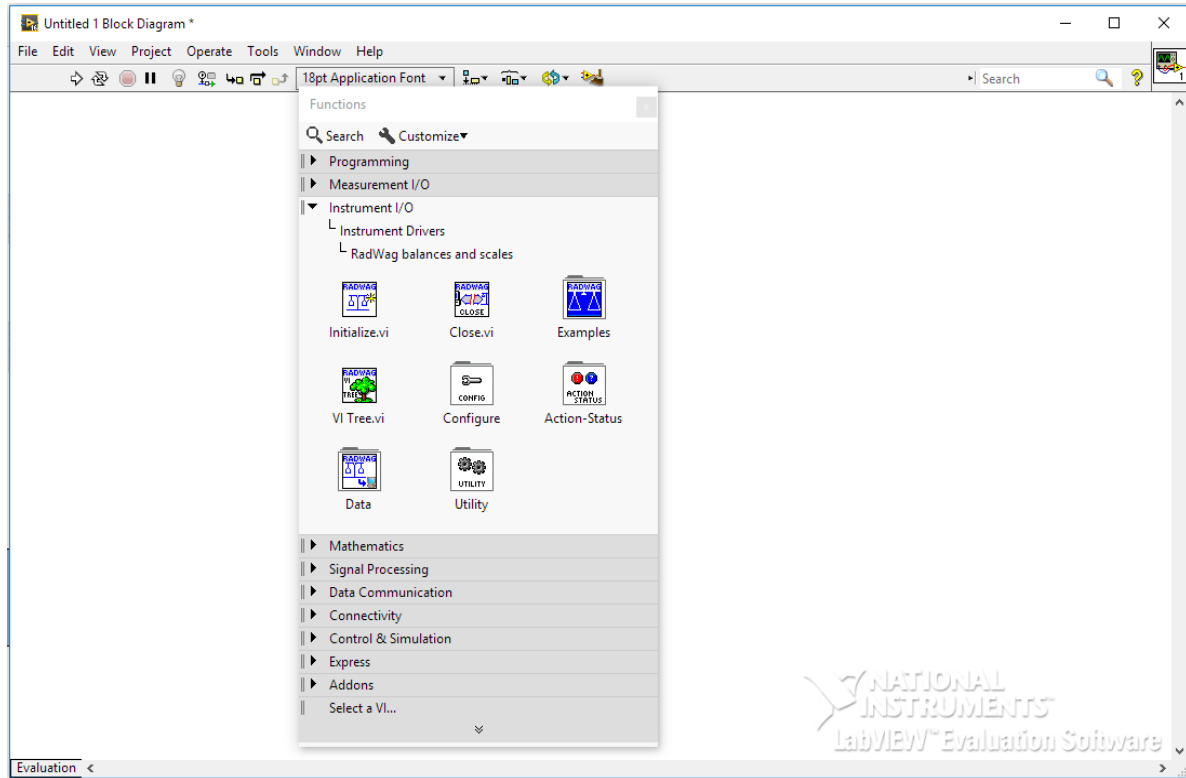

## 5. CONNECTING WITH RADWAG DEVICES

### 5.1. Defining connection using NI-VISA driver

On NI-VISA driver installation, a NI-MAX tool can be found in the system. The tool enables defining connection with selected devices.

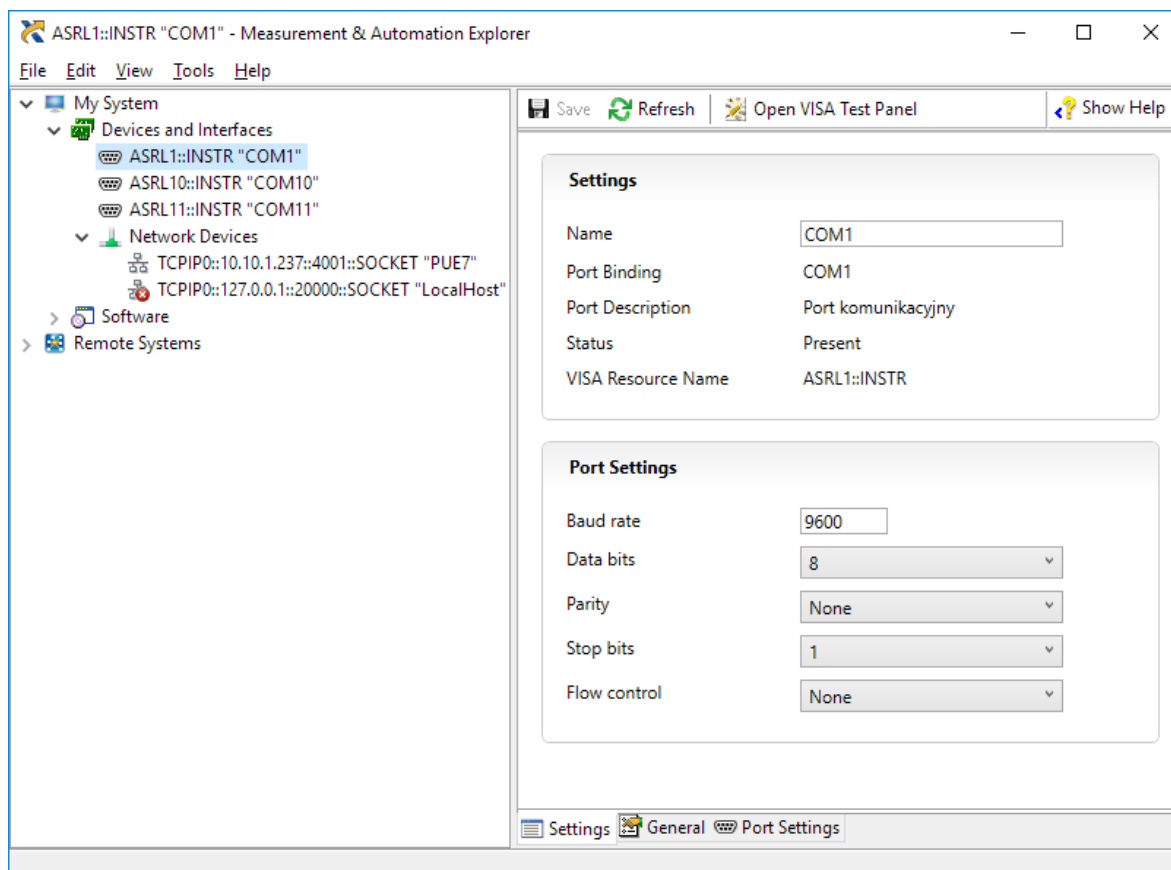

Devices connected to serial ports are available at once since NI-VISA driver automatically creates a connection with each found serial port. In such case, only the configuration of serial port parameters is required.

If the device has defined static IP address, TCP/IP connection for our device can also be defined using NI-MAX tool. Click right mouse button on a menu item: *Network Devices* and select *Create New TCP/IP VISA Resource ...* command.

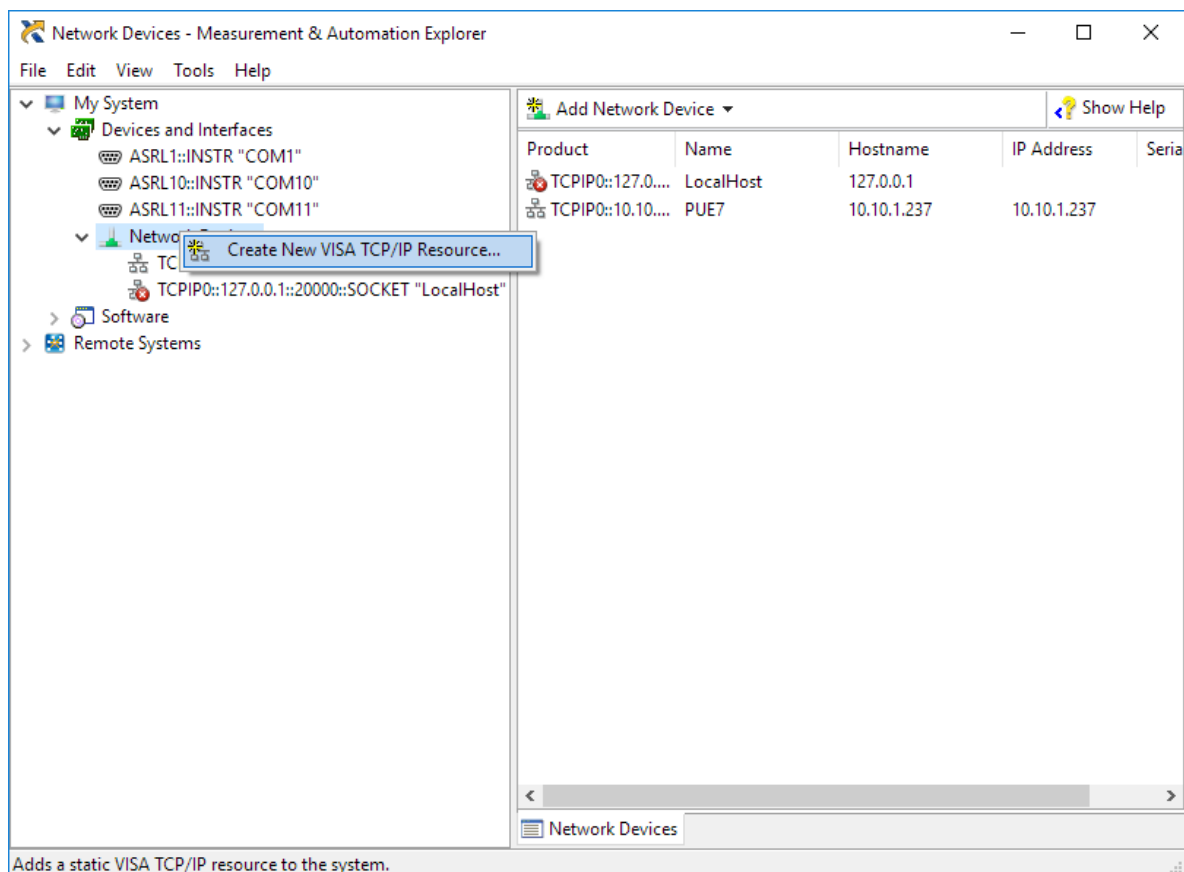

In a displayed wizard select *Manual Entry or Raw Socket*, then press *Next* button.

Next, fill device's IP address and the number of communication port. Press *Next* button.

Define *alias* - the short name for defined connection. Keep in mind *Resource Name* value.

On pressing *Next* button, summary window is displayed. Press *Finish* button to shutdown the wizard - new connection definition is created. It is possible to shutdown the wizard using *Cancel* button - all implemented changes are cancelled.

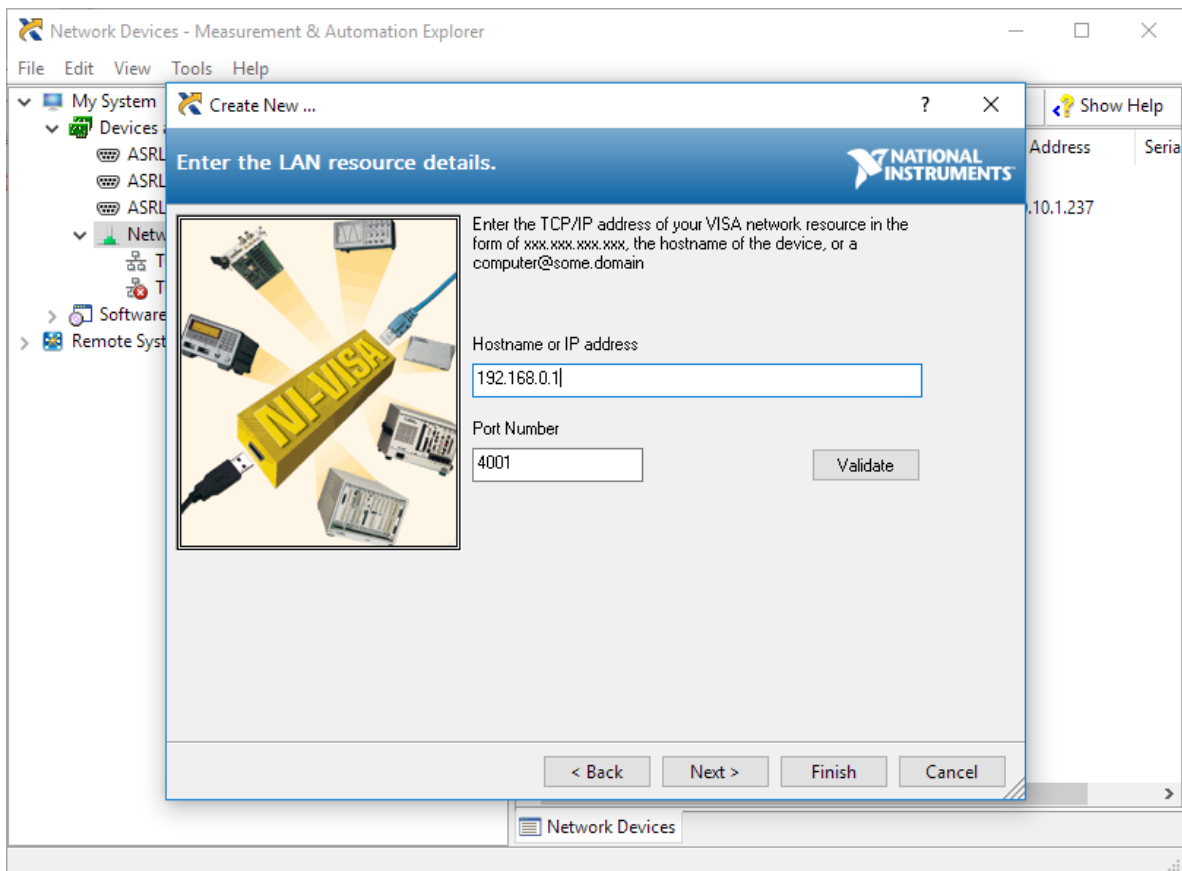
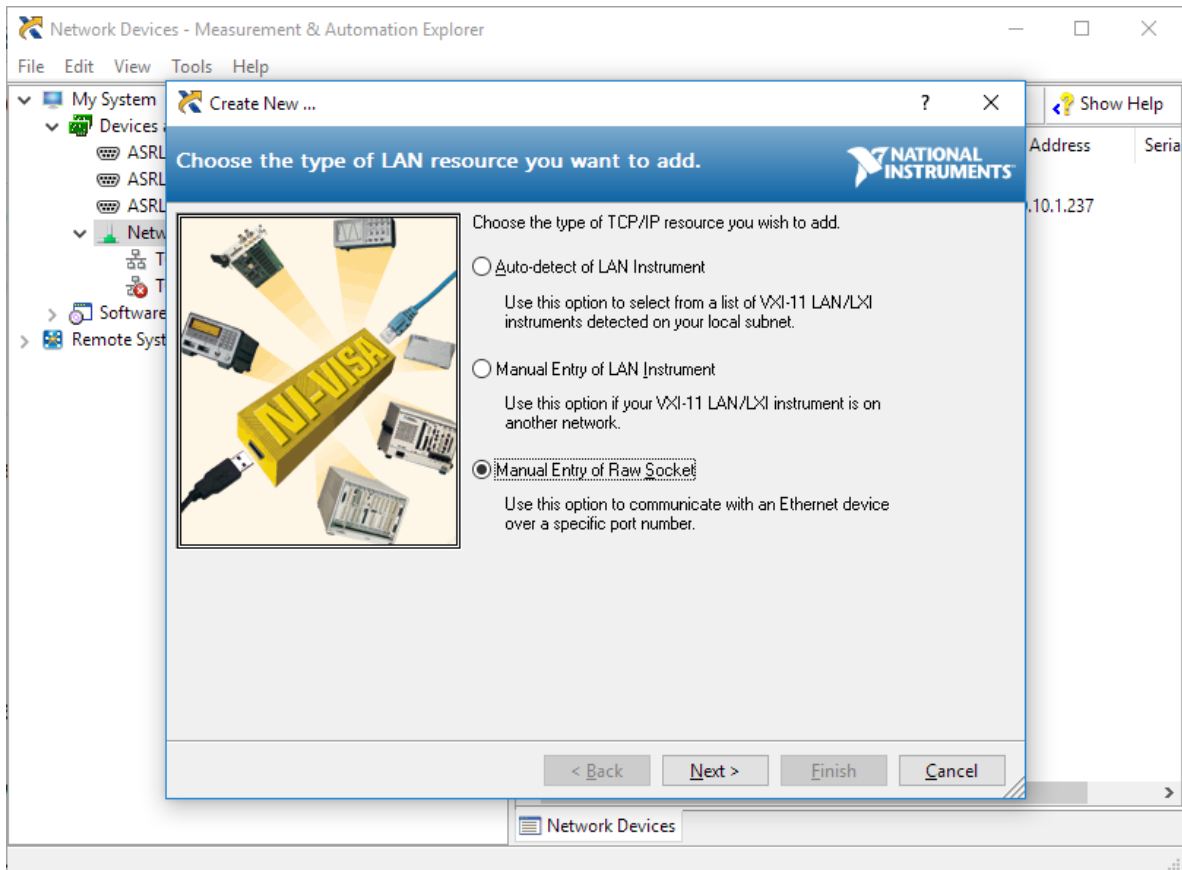



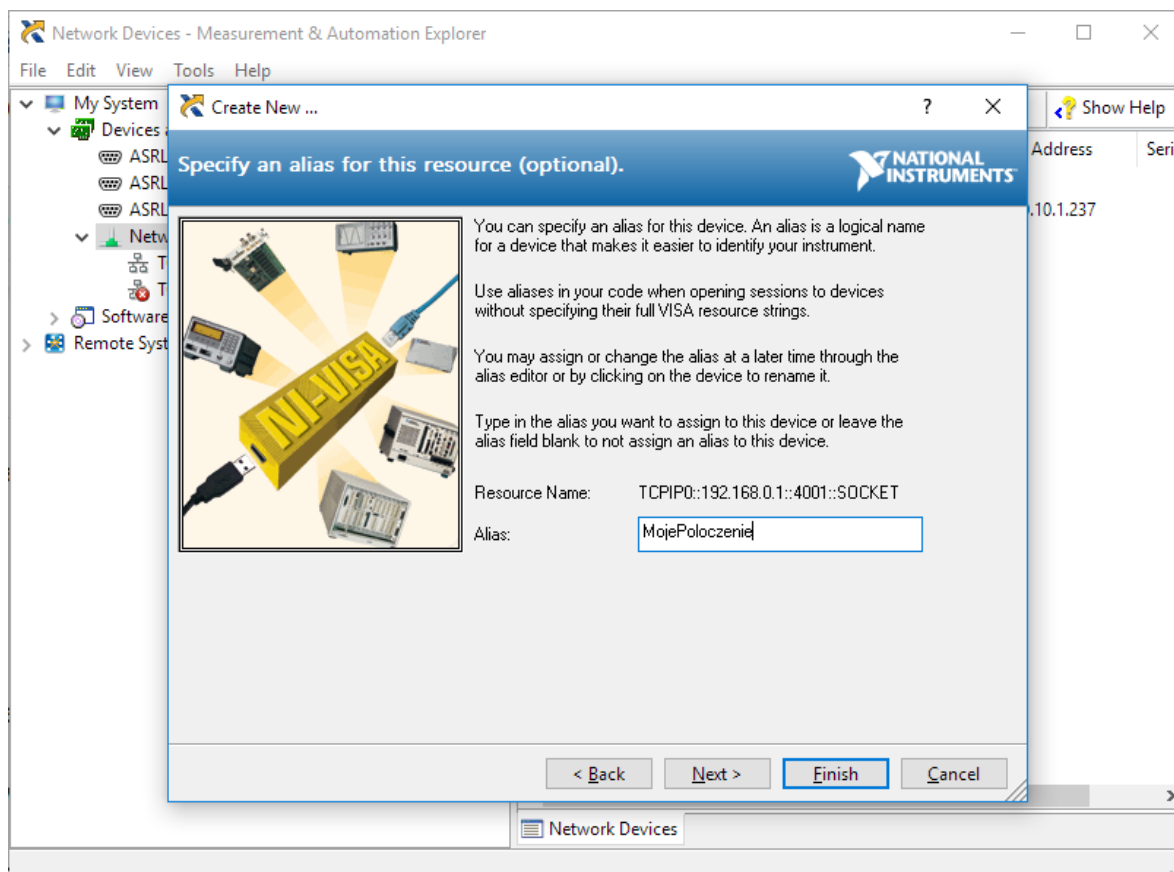

To connections defined like this, we can refer in the program by using *VISA resource name* control. In Block Diagram window, connect the pictogram representing control with connector pane used for defining VISA connection.

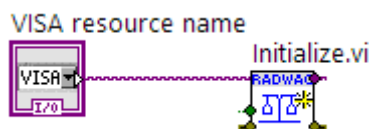

In the front panel the control is represented by a combo box in which all existent aliases of VISA connections or names of connections (when the aliases are not defined) are displayed.

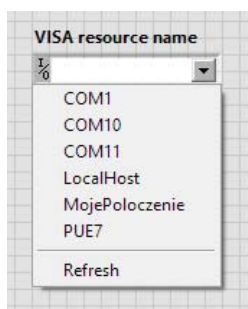

## 5.2. Defining Connection by Defining ConnectionString Value

The connection can be defined by connecting connector panes, for determining VISA connection, with appropriately formatted ConnectionString value. Format of such value is to be defined on the following page: [https://zone.ni.com/reference/en-XX/help/371361J-01/lvinstio/visa\\_resource\\_name\\_generic/](https://zone.ni.com/reference/en-XX/help/371361J-01/lvinstio/visa_resource_name_generic/).

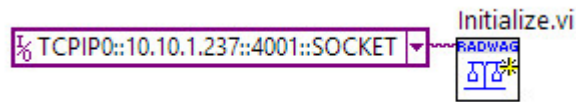

## 5.3. Remarks on Initiating and Terminating the Connection

Use *Initialize* pictogram representing control before pictograms representing operations of data reading and saving. Use *Close* pictogram representing control to organize unused resources. This assures correct operation of buffers for reading and saving information from and to the device.

A diagram of a program using TCPIP protocol for connection with a device of the following address: 10.10.1.237:4001, and collecting measurement from this device.

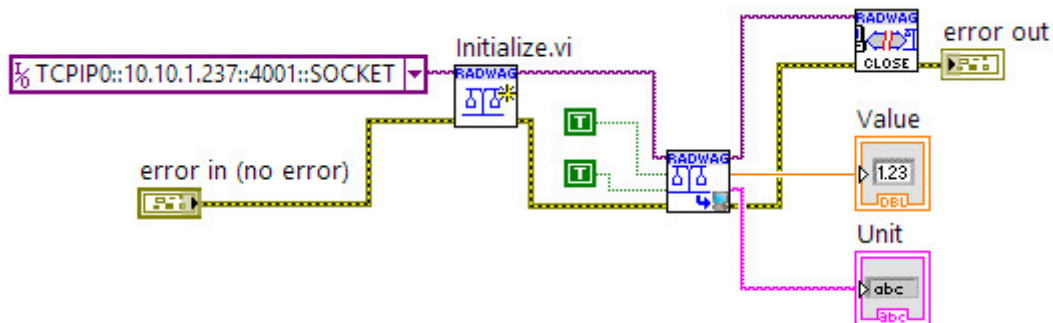



**RADWAG BALANCES AND SCALES**  
ADVANCED WEIGHING TECHNOLOGIES

