

# Weighing modules

## Electromagnetic Weighing Modules

MWSH

MWMH

MWLH

## USER MANUAL

IMMU-18-04-10-18-EN



[www.radwag.com](http://www.radwag.com)

MWMH series modules are not offered or distributed in the following countries: Germany, Switzerland, Italy, Japan and the USA.

Congratulations and thank you for selecting RADWAG product.  
You have purchased a device that has been designed and manufactured to give you years of service.  
Please read this user manual carefully, this shall guarantee reliable operation.

OCTOBER 2018

<b>1.</b>	<b>GENERAL INFORMATION.....</b>	<b>4</b>
1.1.	MWSH Dimensions .....	4
1.2.	MWMH Dimensions.....	5
1.3.	MWLH Dimensions .....	6
1.4.	Connectors Arrangement, MWSH and MWLH Modules.....	7
1.5.	Connectors Arrangement, MWMH Module .....	8
1.6.	Technical Specifications, Basic Parameters.....	9
1.7.	Intended Use .....	10
1.8.	Warranty Conditions .....	10
1.9.	Supervision over Metrological Parameters .....	11
1.10.	User Manual Significance.....	11
1.11.	Operator Training.....	11
<b>2.</b>	<b>TRANSPORT AND STORAGE .....</b>	<b>11</b>
2.1.	Delivery Checklist.....	11
2.2.	Packaging.....	11
<b>3.</b>	<b>UNPACKING AND INSTALLATION .....</b>	<b>11</b>
3.1.	Place of Use .....	11
3.2.	Unpacking.....	12
3.3.	Levelling .....	13
3.4.	Electrical Connection.....	13
<b>4.</b>	<b>USE AND CONFIGURATION.....</b>	<b>14</b>
4.1.	Communication with the Module.....	14
4.2.	Default Communication Parameters .....	14
4.3.	Module Configuration via MWMH-Manager .....	14
4.4.	Integration with Weighing Indicators .....	15
4.5.	Integration with R-LAB Program .....	15
4.6.	Adjustment .....	15
4.7.	Start Mass.....	16
4.8.	Weighing Pan Loading.....	16
4.9.	Maintenance Activities .....	17
<b>5.</b>	<b>CHARACTER-BASED COMMUNICATION PROTOCOL .....</b>	<b>18</b>
5.1.	General Information.....	18
5.2.	Commands Overview.....	20
<b>6.</b>	<b>COMMUNICATION CABLES, POWER SUPPLY .....</b>	<b>28</b>
6.1.	MWSH, MWLH Cables.....	28
6.2.	MWSH, MWLH Power Supply .....	31
6.3.	Diagrams of Connection Cables of MWMH.....	31
<b>7.</b>	<b>ERROR MESSAGES.....</b>	<b>33</b>

# 1. GENERAL INFORMATION

## 1.1. MWSH Dimensions

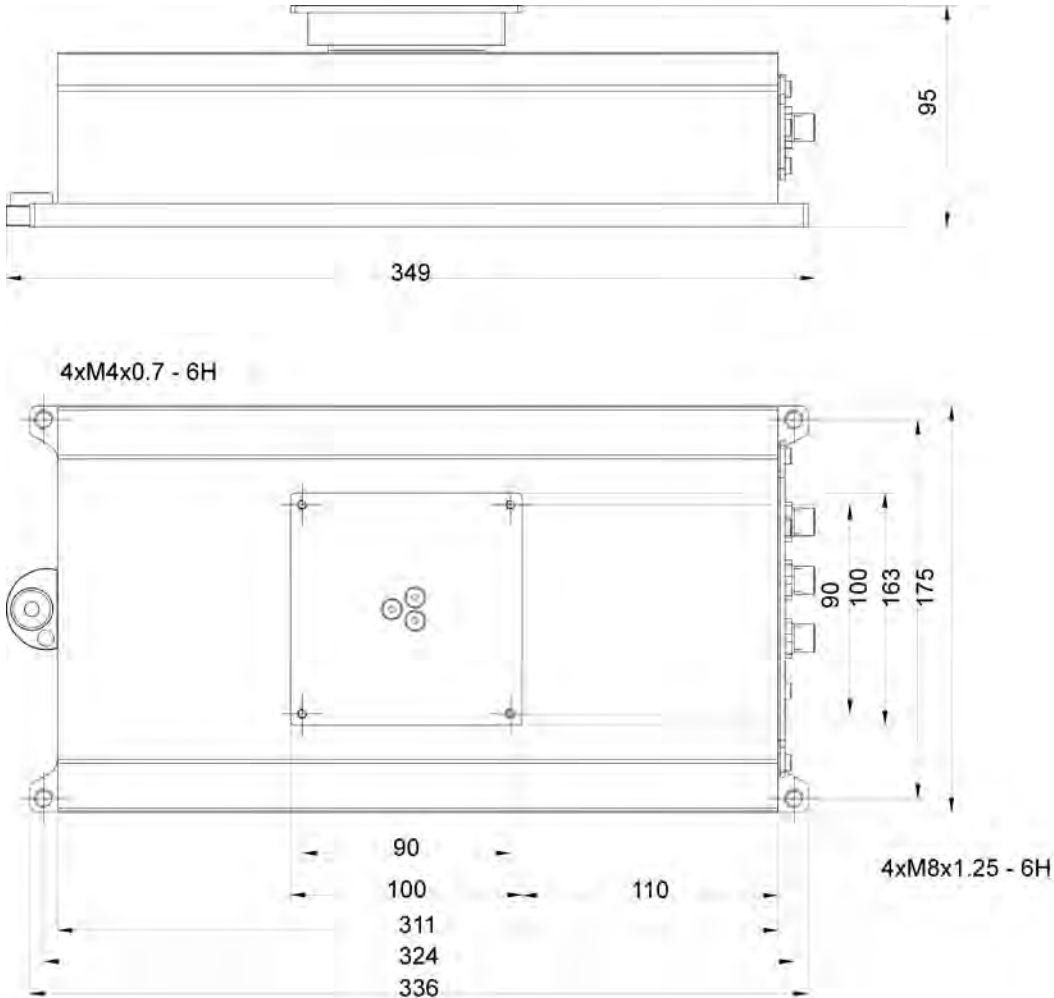

## 1.2. MWMH Dimensions

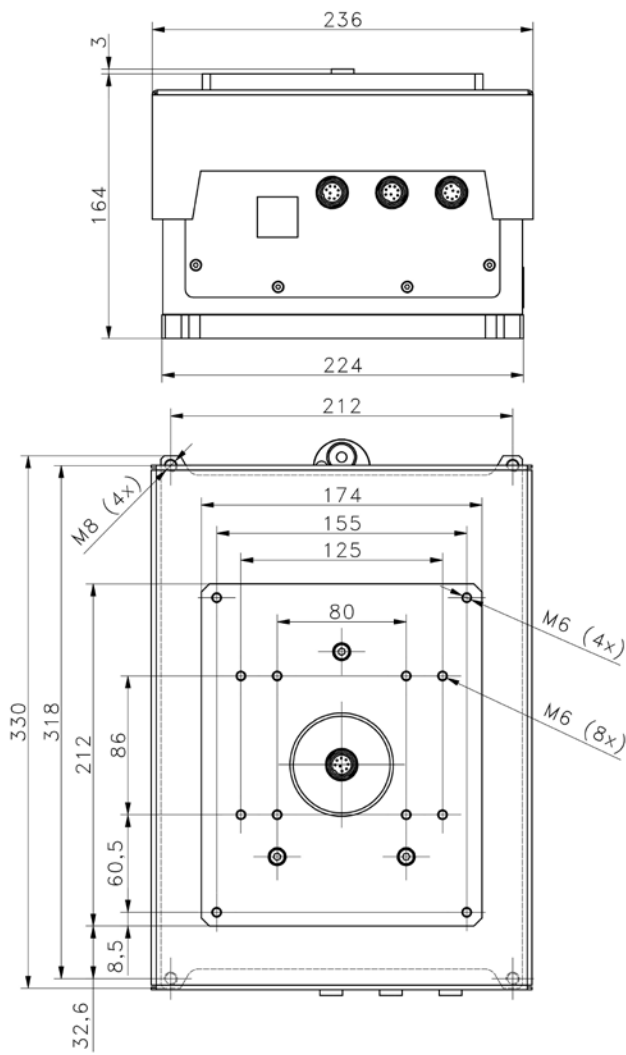

MWMH IP65-H

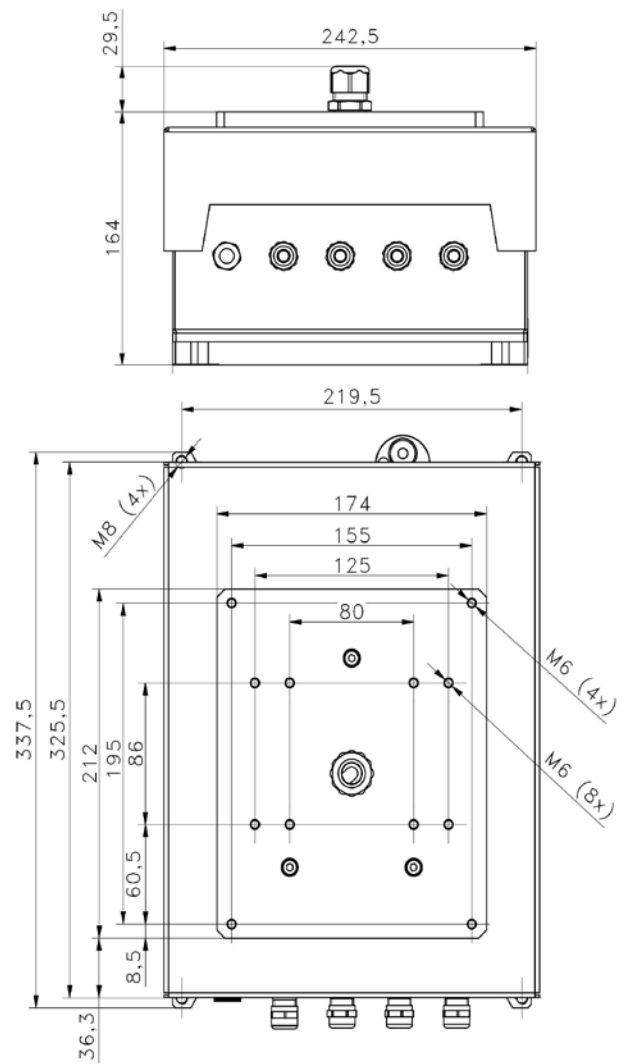

MWMH IP69K

### 1.3. MWLH Dimensions

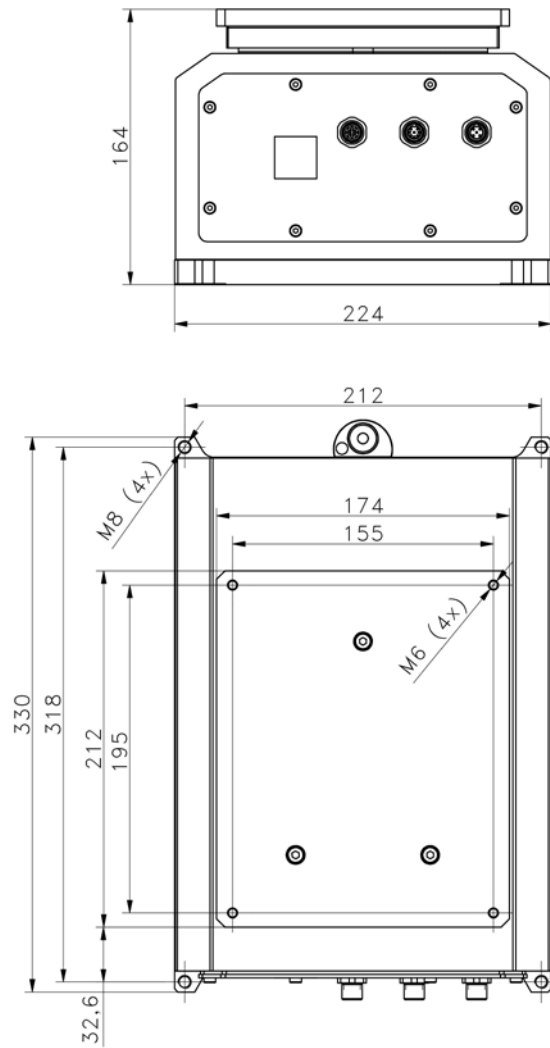

*MWLH IP65*

## 1.4. Connectors Arrangement, MWSH and MWLH Modules

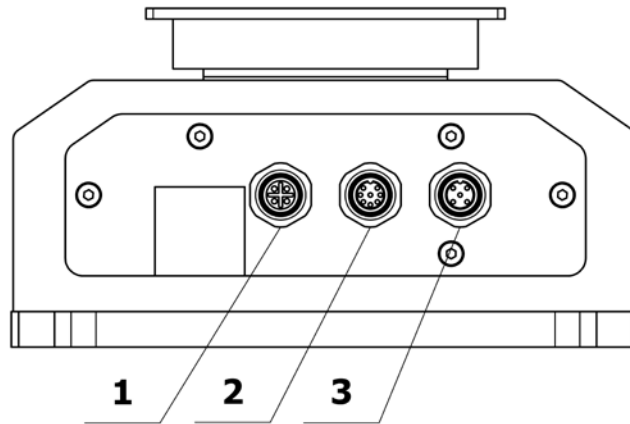

### Standard version

- 1 - Ethernet connector
- 2 - In/Out connector
- 3 - RS232, RS485 + power supply connector

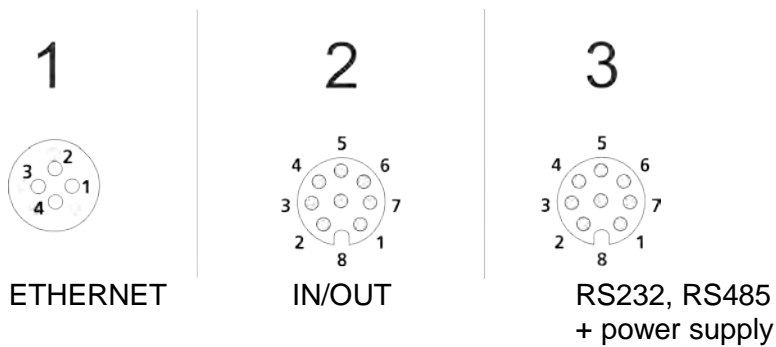

### Profibus version

- 1 - Profibus OUT connector
- 2 - Profibus IN connector
- 3 - RS232 + power supply connector

**Caution:** Module version with Profibus is not equipped with RS485, digital In/Out and Ethernet.

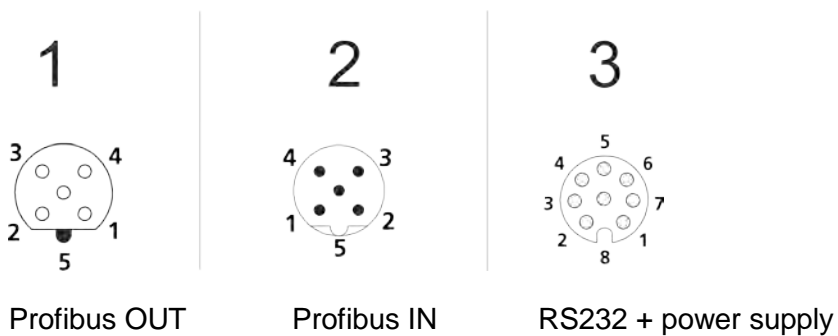

Voltage on a Profibus OUT connector is 5V DC, this provides correct operation of a terminator. M12 5 pin B coded connectors are installed (for PROFIBUS DP).

**HY10, PUE 5, PUE 7.1 versions**

- 2 - In/Out connector
- 3 - RS232, RS485 + power supply connector

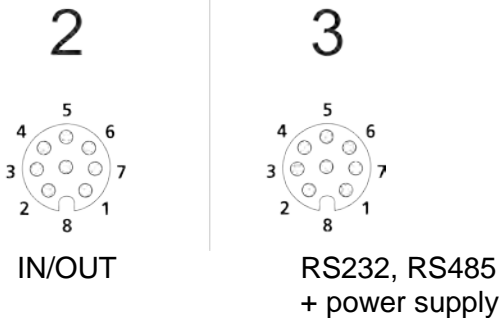

**1.5. Connectors Arrangement, MWMH Module**

Optional version with cables led onto the weighing pan

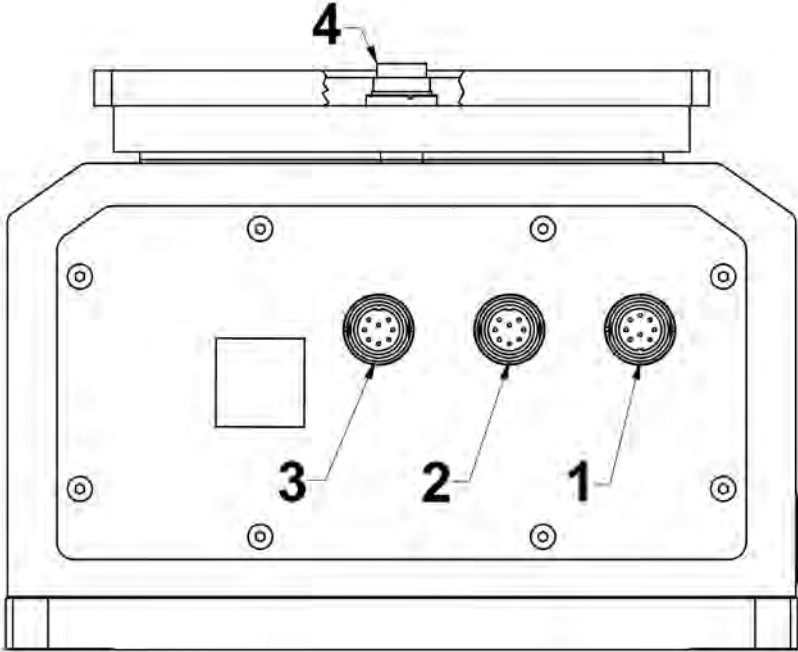

- 1 - In/Out + power supply connector
- 2 - RS232 + Ethernet connector
- 3 and 4 - connectors leading the electric signal onto the weighing pan<sup>1</sup>

<sup>1</sup> Optional version

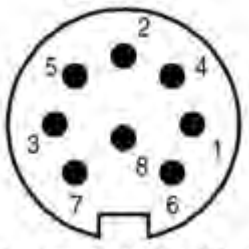
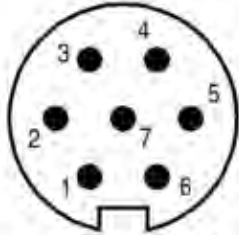
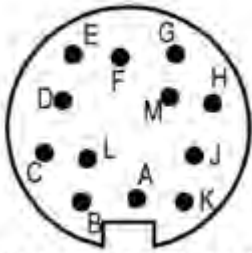

 <p>Binder 09-0173-80-08</p>	 <p>Binder 09-0127-80-07</p>	 <p>Binder 09-0131-80-12</p>
<ul style="list-style-type: none"> <li>1- Power supply</li> <li>2- Control</li> <li>3- Control</li> <li>4- Control</li> <li>5- Control</li> <li>6- Not used</li> <li>7- Power supply</li> <li>8- Power supply</li> </ul>	<ul style="list-style-type: none"> <li>1- RS232 Tx</li> <li>2- Ethernet Tx -</li> <li>3- Ethernet Tx +</li> <li>4- Ethernet Rx -</li> <li>5- Ethernet Rx +</li> <li>6- RS232 Rx</li> <li>7- RS232 GND</li> </ul>	<ul style="list-style-type: none"> <li>A – IN1</li> <li>B – GND Module</li> <li>C – VCC Module</li> <li>D -</li> <li>E – OUT 1</li> <li>F – OUT 2</li> <li>G – VCC Input/Output</li> <li>H – GND Input/Output</li> <li>I –</li> <li>J – IN 2</li> <li>K -</li> <li>L -</li> <li>M -</li> </ul>

Connector No. 3 is internally connected with connector No. 4 located on the weighing pan. The connectors send electrical signals onto the weighing platform. With this solution it is possible to control automation systems that are installed directly on the weighing pan. External electrical wiring, disturbing the weighing process, is no longer needed. Pins 2 - 5 connect control signals. Pins 1, 8 and 7 power the installed equipment. Pins 1 and 8 are electrically connected inside of the module.

### 1.6. Technical Specifications, Basic Parameters

Power supply	12 ÷ 24V DC
Operating temperature	+10 °C - +40 °C
Relative humidity	15% ÷ 80%
Ingress protection	IP 65 or IP68/69K
Output supply voltage	12 ÷ 24V DC
Max output current	100 mA
Input voltage range	12 ÷ 24V DC
Max voltage for connectors 3 and 4	24V DC, 12V AC
Max current for connectors 3 and 4	Pins 2-5 200 mA, Pins 1, 8,7 5A

## 1.7. Intended Use

Professional electromagnetic high resolution modules are intended for use at mass measurement workstations. The modules are designed to be incorporated into customer's weighing systems requiring high IP (ingress protection), great weighing accuracy and high measurement speed. Brand new compact design allows the module to be adapted to various production and processing lines. It may be equipped with customer's weighing pan or conveyor. Signal cables led onto the weighing pan enable connecting automation system devices directly to the module without the need to use external electrical wiring (disturbing the weighing process).

### Precautions

- Prior the first use, carefully read this user manual. Use the device only as intended;
- In case of damage, immediately unplug the device from the mains;
- Module to be decommissioned, should be decommissioned in accordance with valid legal regulations.

## 1.8. Warranty Conditions

- A. RADWAG feels obliged to repair or exchange all elements that appear to be faulty by production or by construction.
- B. Defining defects of unclear origin and means of their elimination can only be realized with assistance of the manufacturer and user representatives.
- C. RADWAG does not bear any responsibility for damage or losses resulting from unauthorized or inadequate performing of production or service processes.
- D. The warranty does not cover:
  - mechanical damage caused by product exploitation other than intended, damage of thermal and chemical origin, damage caused by lightning, overvoltage in the power network or other random event,
  - damage caused by product exploitation other than intended,
  - mechanical damage, if service claims removing or destroying security seal stickers which protect construction against unauthorized access,
  - damage caused by liquids and natural wear,
  - damage caused by inappropriate setting or by electrical wiring failures,
  - damage caused by overloading of the measuring system,
  - inappropriate cleaning habits.
- E. Loss of warranty takes place if:
  - a repair is carried out outside RADWAG authorized service point,
  - service claims intrusion into mechanical or electronic construction by unauthorized people,
  - the platform does not bear Radwag security stickers.
- F. For detailed warranty conditions read the warranty certificate.

## **1.9. Supervision over Metrological Parameters**

Metrological parameters need to be checked in determined time intervals. Inspection frequency is conditioned by ambient conditions in which the module is used, type of carried out processes and adopted quality management system.

### **1.10. User Manual Significance**

Even if you are experienced and have already worked with this type of weighing instrument, you are still obliged to read this user manual carefully prior switching the device on. This user manual provides all necessary operation-related information. Following the user manual guidelines guarantees correct weighing instrument performance.

### **1.11. Operator Training**

Modules can be operated and supervised only by the trained staff.

## **2. TRANSPORT AND STORAGE**

### **2.1. Delivery Checklist**

Upon delivery it is necessary to check the package and the device. Make sure that your package and the instrument bear no signs of damage.

### **2.2. Packaging**

Keep all package elements should your device be transported in the future. Remember that only original packaging can be used for shipping purposes. Prior packing, uncouple any cables, remove any separable components (weighing pan, shields, inserts). The device components must be packed into an original packaging providing protection against potential damage during transportation.

## **3. UNPACKING AND INSTALLATION**

### **3.1. Place of Use**

- Make sure that the ambient temperature ranges between: +10 °C ÷ +40 °C,
- Make sure that the relative humidity is not higher than 80%,
- Make sure that temperature change in the course of operation is not rapid,
- Ground the module's base should the static electricity affect the weighing result,

- Install the module on a stable vibration-free construction, away from heat sources and magnetic field,
- The module and its weighing pan have to be shielded against air drafts,
- In case of modules stored in temperature that significantly differs from the temperature in the place of installation, wait until the module reaches temperature stabilization.

### **3.2. Unpacking**

Cut the adhesive tape. Take the device out of the packaging. Be particularly careful while unpacking the device and installing its components so as not to cause any damages to the module mechanism.

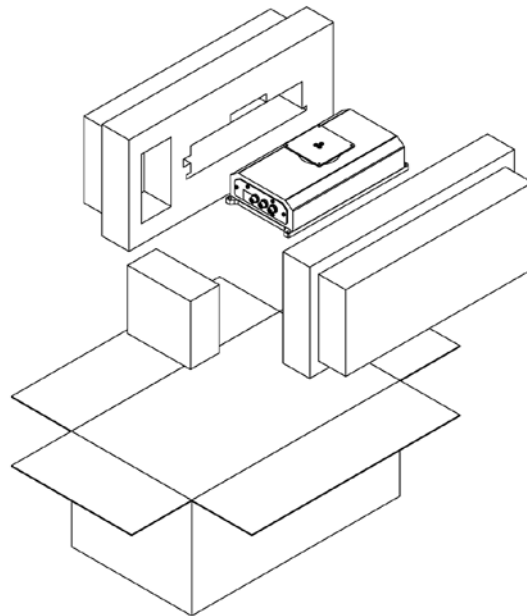

*MWSH Module*

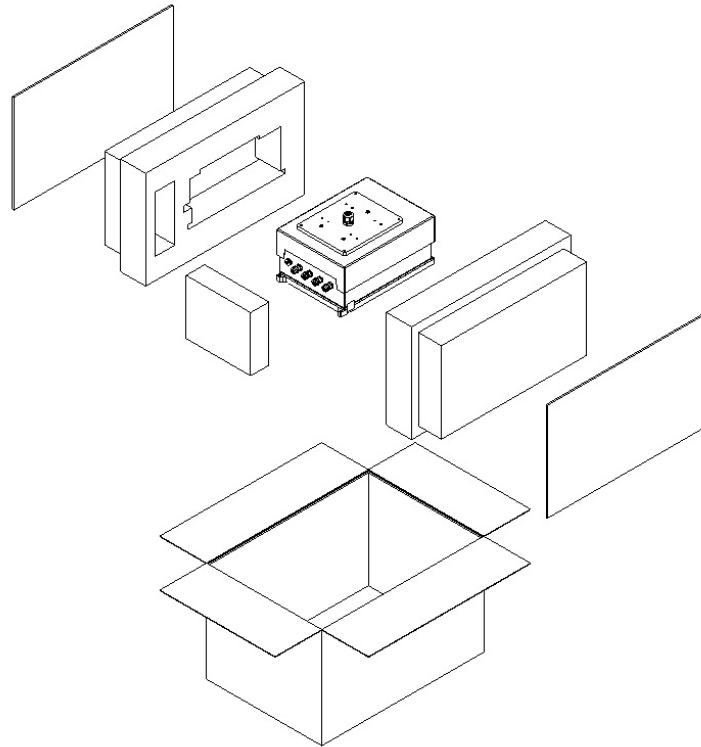

*MWMH / MWLH Module*

### **3.3. Levelling**

Upon placing the weighing instrument at the workstation, carry out levelling. To level the device turn its feet, keep turning the feet until the air bubble takes central position.

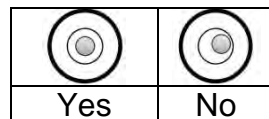

### **3.4. Electrical Connection**

Upon completed mechanical installation, carry out electrical connections. Depending on the preferred communication type, connect respective communication cables to the appropriate connector. It is recommended to use original communication cables supplied by RADWAG. Nominal voltage of the power supply (specified on the power supply data plate) has to be compatible with the mains nominal voltage.

## 4. Use and Configuration

### 4.1. Communication with the Module

RADWAG-manufactured electromagnetic modules can communicate with weighing indicators, computer applications and industrial controllers via RS232, Ethernet, RS485 and Profibus connectors.

Communication protocols of the modules:

- RADWAG character-based protocol
- Modbus RTU (RS485)
- Modbus TCP (Ethernet)
- Profibus

Standard version of the module additionally features digital 2 In and 2 Out which enable taring, zeroing, dosing start and stop, and signalling of the weighing thresholds.

#### **Caution:**

*Module version with Profibus is not equipped with RS485, digital In/Out and Ethernet.*

### 4.2. Default Communication Parameters

- RS232

Baud rate	57600
Data bits	8
Parity	none
Stop bits	1
- RS485

Baud rate	57600
Data bits	8
Parity	none
Stop bits	1
Module address	1
- TCP/IP

IP address	192.168.0.2
Subnet mask	255.255.255.0
Default gateway	192.158.0.1
Port	4001

### 4.3. Module Configuration via MWMH-Manager

„**MWMH-Manager**” is a computer software, operating in MS Windows environment, intended for operation and configuration of parameters of MWSH, MWMH, MWLH electromagnetic weighing modules. The program enables: mass readout, taring,

zeroing, filters setting, adjustment, communication parameters configuration, simulation of digital inputs and outputs.

„**MWMH-Manager**” software communicates with the modules via RS232, RS485 and TCP/IP. For detailed description of the **MWMH-Manager** software read MWMH-Manager user manual.

#### 4.4. Integration with Weighing Indicators

Electromagnetic weighing modules are compatible with the following indicators: HY 10, PUE 5 and PUE 7.1. Communication between the devices is established via RS232, RS485 and Ethernet connectors. A set comprising the weighing module and the indicator makes a high resolution weighing instrument offering applications intended for industry. The weighing indicator enables unlimited access to module parameters and allows carrying out adjustment procedure.



**PUE HY10 Indicator**



**PUE 5 Indicator**



**PUE 7.1 Indicator**

#### 4.5. Integration with R-LAB Program

R-LAB program is a computer application that enables readout of mass values from connected modules, collection of measurements, taring and zeroing. The program connects with the module via RS232 and Ethernet.

#### 4.6. Adjustment

In order to ensure high weighing accuracy, it is necessary to correct indications periodically against a mass standard, this requires entering a corrective factor to module memory. Adjustment has to be carried out before weighing, after a long break between measurement series or in case of rapid ambient temperature change. The adjustment has to be carried out when the weighing pan is unloaded and working conditions are stable (no drafts and vibrations). If one of the above conditions is not fulfilled, an error message is displayed. In such case, unload the weighing pan or eliminate other distorting factors and repeat the adjustment. Do not use the module until the adjustment is carried out. In the course of the adjustment follow the displayed messages. In case of modules equipped with an internal weight, the adjustment can be carried out using either this weight or an external one. Modules not equipped with an internal weight can only be adjusted using external weight.

There are three types of adjustment:

- adjustment performed using an external weight,

- automatic internal adjustment initiated by the module,
- internal adjustment initiated by an operator.

The adjustment performed using an external weight can be carried out via:

- MWMH-Manager - program for platforms and modules operation,
- weighing indicator connected to the module.

Internal adjustment can be initiated by:

- MWMH-Manager - program for platforms and modules operation,
- weighing indicator connected to the module,
- **IC** command of the communication protocol,
- command of the Profibus protocol,
- command of the Modbus protocol.

### **Caution**

*Verified modules cannot be adjusted using an external weight.*

## **4.7. Start Mass**

You can determine zero point of an electromagnetic weighing module. This option is used in case of applying an additional conveyor, or container, that permanently loads the module. Determining start mass with an additional load does not reduce module's maximum capacity. Option is available via:

- MWMH-Manager - program for platforms and modules operation,
- weighing indicator connected to the module.

### **Caution**

*Determination of start mass carried out by an operator is not possible in case of verified modules.*

## **4.8. Weighing Pan Loading**

- A. Place weighed loads in the centre of the weighing pan;

**CORRECT**

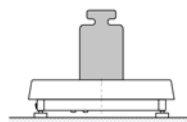

**INCORRECT**

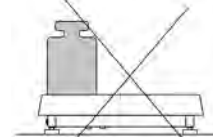

- B. Load the weighing pan with loads of gross weight which does not exceed the maximum capacity;



- C. In case of eccentric loading make sure that:
- the weight of loads placed close to one of the pan edges does not exceed  $\frac{1}{2}$  of the max capacity,
  - the weight of loads placed in the pan corner does not exceed  $\frac{1}{3}$  of the max capacity.

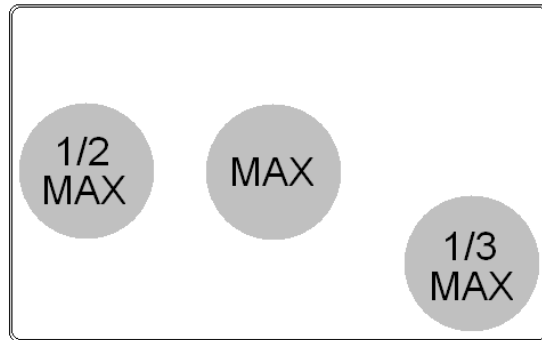

- D. Mind not to leave heavy loads on the weighing pan for longer periods of time;
- E. Avoid side shocks and impacts;

INCORRECT

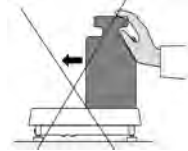

INCORRECT

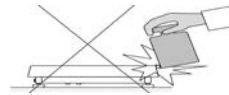

CORRECT

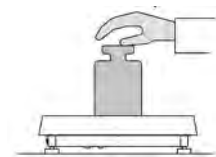

INCORRECT

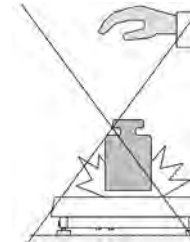

#### 4.9. Maintenance Activities

**Caution:**

- While cleaning the weighing pan be careful so as not to damage the mechanism.

- *For maintenance use mild cleanser preventing corrosion.*
- *Avoid directing strong stream of water directly onto weighing module's gasket membrane.*

### Cleaning Stainless Steel Components

Avoid using cleansers containing any corrosive chemicals, e.g. bleach (including chlorine). Do not use products containing abrasive substances. Always remove the dirt using microfiber cloth to avoid damage of protective coating.

In case of a daily maintenance:

- Remove the dirt using cloth dipped in warm water.
- For best results, add a little dishwashing detergent.

### Cleaning Powder-Coated Components

For preliminary cleaning stage you need running water or wet sponge featuring large holes, this will help you to remove loose, heavy dirt.

Do not use products containing abrasive substances.

Next, using cloth and cleanser-water solution (soap, dishwashing liquid) gently rub the cleaned surface.

Avoid using cleanser without water since it may result with damage of the cleaned surface, please mind that large amount of water mixed with cleanser is a must.

### Cleaning Aluminium Components

While cleaning aluminium components use products acid by nature, e.g. spirit vinegar, lemon. Do not use products containing abrasive substances. Avoid using hard brush, this may cause scratches. It is recommended to use microfibre cloth.

While polishing the surface use circular movements. Use clean, dry cloth. For best results, add a little dishwashing detergent.

## **5. CHARACTER-BASED COMMUNICATION PROTOCOL**

### **5.1. General Information**

- A character based communication protocol (module-indicator) is designed for establishing communication between a RADWAG module and a peripheral device via RS232, RS485 and Ethernet.
- The protocol consists of commands sent from a peripheral device to the weighing device and responses from the weighing device.

- Responses are sent from the weighing device each time a command is received.
- Commands, forming the communication protocol, enable obtaining data on weighing device status and facilitate influencing weighing device operation, e.g.: acquiring measurement results from the weighing device, zeroing, etc.

#### List of commands

<b>Command</b>	<b>Command overview</b>
<b>Z</b>	Zero the platform
<b>T</b>	Tare the platform
<b>OT</b>	Give tare value
<b>UT</b>	Set tare
<b>S</b>	Send stable measurement result in basic measuring unit
<b>SI</b>	Immediately send measurement result in basic measuring unit
<b>SU</b>	Send stable measurement result in current measuring unit
<b>SUI</b>	Immediately send measurement result in current measuring unit
<b>C1</b>	Switch on continuous transmission in basic measuring unit
<b>C0</b>	Switch off continuous transmission in basic measuring unit
<b>CU1</b>	Switch on continuous transmission in current measuring unit
<b>CU0</b>	Switch off continuous transmission in current measuring unit
<b>DH</b>	Set min checkweighing threshold
<b>UH</b>	Set max checkweighing threshold
<b>ODH</b>	Give value of min checkweighing threshold
<b>OUH</b>	Give value of max checkweighing threshold
<b>NB</b>	Give scale serial number
<b>UI</b>	Give accessible units
<b>US</b>	Set unit
<b>UG</b>	Give current unit
<b>BN</b>	Give scale type
<b>FS</b>	Give max capacity
<b>RV</b>	Give program version
<b>A</b>	Set AUTOZERO function
<b>PC</b>	Send all implemented commands
<b>FIS</b>	Set filter
<b>GIN</b>	Give status of input settings
<b>GOUT</b>	Give status of output settings
<b>SOUT</b>	Set outputs
<b>IC</b>	Internal adjustment
<b>PS</b>	Send module settings

**Caution:** Each command must end with CR LF characters. Response format:

<b>XX_A CR LF</b>	command understood and in progress
<b>XX_D CR LF</b>	command carried out (appears only after the XX_A command)
<b>XX_I CR LF</b>	command understood but not accessible at this moment
<b>XX _ ^ CR LF</b>	command understood but max threshold is exceeded
<b>XX _ v CR LF</b>	command understood but min threshold is exceeded
<b>XX _ OK CR LF</b>	command carried out
<b>ES_CR LF</b>	command not recognised
<b>XX _ E CR LF</b>	time limit exceeded while waiting for stable measurement result (time limit is a characteristic scale parameter)

**XX** - name of a sent command  
 \_ - space

## 5.2. Commands Overview

### Zero Scale

Format: **Z CR LF**

Response options:

Z\_A CR LF - command understood and in progress  
 Z\_D CR LF - command carried out  
 Z\_A CR LF - command understood and in progress  
 Z\_^ CR LF - command understood but zeroing range is exceeded  
 Z\_A CR LF - command understood and in progress  
 Z\_E CR LF - time limit exceeded while waiting for stable measurement result  
 Z\_I CR LF - command understood but not accessible at this moment

### Tare Scale

Format: **T CR LF**

Response options:

T\_A CR LF - command understood and in progress  
 T\_D CR LF - command carried out  
 T\_A CR LF - command understood and in progress  
 T\_v CR LF - command understood but taring range is exceeded  
 T\_A CR LF - command understood and in progress  
 T\_E CR - time limit exceeded while waiting for stable measurement result  
 T\_I CR LF - command understood but not accessible at this moment

### Give Tare Value

Format: **OT CR LF**

Response: **OT\_TARE CR LF** - command carried out

Response format:

1	2	3	4-12	13	14	15	16	17	18	19
O	T	space	tare	space	unit			space	CR	LF

**Tare** - 9 characters, right justification

**Unit** - 3 characters, left justification

**Caution:** Tare value is always given in an adjustment unit.

### Set Tare

Format: **UT\_TARE CR LF**, where **TARE** - tare value

Response options:

**UT\_OK CR LF** - command carried out

**UT\_I CR LF** - command understood but not accessible at this moment

**ES CR LF** - command not recognised (tare format incorrect)

**Caution:**

Use dot in tare format as decimal point.

### Send Stable Measurement Result in Basic Measuring Unit

Format: **S CR LF**

Response options:

**S\_A CR LF** - command understood and in progress

**S\_E CR LF** - time limit exceeded while waiting for stable measurement result

**S\_I CR LF** - command understood but not accessible at this moment

**MASS FRAME** - command carried out, response: mass value in basic measuring unit

Response format:

1	2-3	4	5	6	7-15	16	17	18	19	20	21
S	space	stability marker	space	character	mass	space	unit			CR	LF

**Example:**

**S CR LF** - command sent from a computer

**S \_ A CR LF** - command understood and in progress

**S \_ \_ \_ \_ - \_ \_ \_ \_ \_ 8 . 5 \_ g \_ \_ CR LF** - command carried out, response: mass value in basic measuring unit

where: \_ - space

### Immediately Send Measurement Result in Basic Measuring Unit

Format: **SI CR LF**

Response options:

**SI\_I CR LF** - command understood but not accessible at this moment

**MASS FRAME** - command carried out, immediate response: mass value in basic measuring unit

Response format:

1	2	3	4	5	6	7-15	16	17	18	19	20	21
S	I	space	stability marker	space	character	mass	space	unit			CR	LF

**Example:**

**S I CR LF** - command sent from a computer

**S I \_ ? \_ \_ \_ \_ \_ 1 8 . 5 \_ k g \_ CR LF** - command carried out, immediate response: mass value in basic measuring unit

where: \_ - space

### Send Stable Measurement Result in Current Measuring Unit

Format: **SU CR LF**

Response options:

SU\_A CR LF - command understood and in progress

SU\_E CR LF - time limit exceeded while waiting for stable measurement result

SU\_I CR LF - command understood but not accessible at this moment

MASS FRAME - command carried out, response: mass value in current measuring unit

Response format:

1	2	3	4	5	6	7-15	16	17	18	19	20	21
S	U	space	stability marker	space	character	mass	space	unit			CR	LF

**Example:**

**S U CR LF** - command sent from a computer

**S U \_ A CR LF** - command understood and in progress

**S U \_ \_ \_ - \_ \_ 1 7 2 . 1 3 5 \_ N \_ \_ CR LF** - command carried out, response: mass value in current measuring unit.

where: \_ - space

### Immediately Send Measurement Result in Current Measuring Unit

Format: **SUI CR LF**

Response options:

SUI\_I CR LF - command understood but not accessible at this moment

MASS FRAME - command carried out, immediate response: mass value in current measuring unit

Response format:

1	2	3	4	5	6	7-15	16	17	18	19	20	21
S	U	I	stability marker	space	character	mass	space	unit			CR	LF

**Example:**

**S U I CR LF** - command sent from a computer

**S U I ? \_ - \_ \_ \_ 5 8 . 2 3 7 \_ k g \_ CR LF** - command carried out, immediate response: mass value in current measuring unit.

where: \_ - space

### Switch on Continuous Transmission in Basic Measuring Unit

Format: **C1 CR LF**

Response options:

C1\_I CR LF - command understood but not accessible at this moment

C1\_A CR LF - command understood and in progress

MASS FRAME - command carried out, response: mass value in basic measuring unit

Response format:

1	2	3	4	5	6	7-15	16	17	18	19	20	21
S	I	space	stability marker	space	character	mass	space	unit			CR	LF

### Switch off Continuous Transmission in Basic Measuring Unit

Format: **C0 CR LF**

Response options:

C0\_I CR LF - command understood but not accessible at this moment

C0\_A CR LF - command understood and carried out

### Switch on Continuous Transmission in Current Measuring Unit

Format: **CU1 CR LF**

Response options:

CU1\_I CR LF - command understood but not accessible at this moment

CU1\_A CR LF - command understood and in progress

MASS FRAME - response: mass value in current measuring unit

Response format:

1	2	3	4	5	6	7-15	16	17	18	19	20	21
S	U	I	stability marker	space	character	mass	space	unit			CR	LF

### Switch off Continuous Transmission in Current Measuring Unit

Format: **CU0 CR LF**

Response options:

CU0\_I CR LF - command understood but not accessible at this moment

CU0\_A CR LF - command understood and carried out

### Set Min Checkweighing Threshold

Format: **DH\_XXXXX CR LF**, where: \_ - space, **XXXXX** - mass format

Response options:

DH\_OK CR LF - command carried out

ES CR LF - command not recognised (mass format incorrect)

### Set Max Checkweighing Threshold

Format: **UH\_XXXXX CR LF**, where: \_ - space, **XXXXX** - mass format

Response options:

UH\_OK CR LF - command carried out

ES CR LF - command not recognised (mass format incorrect)

**Give Value of Min Checkweighing Threshold**

Format: **ODH CR LF**

Response: **DH\_MASS CR LF** - command carried out

Response format:

1	2	3	4-12	13	14	15	16	17	18	19
D	H	space	mass	space	unit		space	CR	LF	

**Mass** - 9 characters, right justification

**Unit** - 3 characters, left justification

**Give Value Of Max Checkweighing Threshold**

Format: **OUH CR LF**

Response: **UH\_MASS CR LF** - command carried out

Response format:

1	2	3	4-12	13	14	15	16	17	18	19
U	H	space	mass	space	unit		space	CR	LF	

**mass** - 9 characters, right justification

**Unit** - 3 characters, left justification

**Give Scale Serial Number**

Format: **NB CR LF**

Response options:

NB\_A\_ "x" CR LF - command understood, response: serial number

NB\_I CR LF - command understood but not accessible at this moment

x - module serial number, inserted in between inverted commas

Example:

Command: NB CR LF - give serial number

Response: NB\_A\_ "1234567" - module serial number: "1234567"

**Give Accessible Units**

Command overview:

Command returns units available for a particular device and for a current working mode.

Format: **UI <CR><LF>**

Response options:

**UI\_ "x<sub>1</sub>,x<sub>2</sub>, ... x<sub>n</sub>"\_OK<CR><LF>** - command carried out, response: accessible units

**UI\_I <CR><LF>** - command understood but not accessible at this moment

x - unit symbols, separated by means of commas

x → g, mg, ct, lb, oz, ozt, dwt, tlh, tls, tlt, tlc, mom, gr, ti, N, baht, tola, u1, u2

Example:

Command: UI <CR><LF> - return available units

Response: UI\_ "g, mg, ct"\_OK<CR><LF> - response: available units



## Set Unit

Command overview:

Command sets current unit for a particular device.

Format: **US\_x <CR><LF>**

Response options:

**US\_x\_OK <CR><LF>** - command carried out, response: currently set unit

**US\_E <CR><LF>** - error in-course of command execution, no parameter or incorrect format

**US\_I <CR><LF>** - command understood but not accessible at this moment

**x** - parameter, units symbols: g, mg, ct, lb, oz, ozt, dwt, tlh, tls, tlt, tlc, mom, gr, ti, N, baht, tola, msg, u1, u2, next.

**Caution:**

If x=next the command swaps to another available unit on the list (it simulates  button pressing, or taping unit field in mass window).

Example:

Command: **US\_mg<CR><LF>** - set „mg” unit

Response: **US\_mg\_OK<CR><LF>** - „mg” set as a current unit

## Give Current Unit

Command overview:

Command returns current unit.

Format: **UG <CR><LF>**

Response options:

**UG\_x\_OK<CR><LF>** - command carried out, response: currently set unit

**UG\_I <CR><LF>** - command understood but not accessible at this moment

**x** - parameter, units symbol

Example:

Command: **UG<CR><LF>** - return current unit

Response: **UG\_ct\_OK<CR><LF>** - currently set unit is „ct”

## Send All Implemented Commands

Format: **PC<CR><LF>**

Command: **PC CR LF** - send all implemented commands

Response: **PC\_A\_”Z,T,S,SI...”** - command carried out, the indicator sent all implemented commands.

## Give Max Capacity

Format: **FS <CR><LF>**

Response options:

**FS\_A\_”x” <CR><LF>** - command understood, response: Max capacity

**FS\_I <CR><LF>** - command understood but not accessible at this moment

**x** - Max value of reading units (in between inverted commas)

Example:

Command: FS <CR><LF> - return Max capacity  
- Max capacity: "220 g"  
Response: FS\_A\_ "220.0000"

### Give Program Version

Format: RV <CR><LF>

Response options:

RV\_A\_ "x" <CR><LF> - command understood, response: program version  
RV\_I <CR><LF> - command understood but not accessible at this moment  
x - program version (in between inverted commas)

Example:

Command: RV <CR><LF> - return program version  
Response: RV\_A\_ " 1.1.1" - program version: "1.1.1"

### Set AUTOZERO Function

Format: A\_n <CR><LF>

Response options:

A\_OK <CR><LF> - command carried out  
A\_E <CR><LF> - error in-course of command execution, no parameter or incorrect format  
A\_I <CR><LF> - command understood but not accessible at this moment  
n - parameter, decimal value determining autozero settings  
n → 0 – autozero off  
1 – autozero on

#### Caution:

Command changes settings for a current working mode.

Example:

Command: A\_1<CR><LF> - turn autozero function on  
Response: A\_OK<CR><LF> - autozero function is on

***AUTOZERO function operates until it is turned off by A 0 command.***

### Set Filter

Format: FIS\_n <CR><LF>

Response options:

FIS\_OK <CR><LF> - command carried out  
FIS\_E <CR><LF> - error in-course of command execution, no parameter or incorrect format  
FIS\_I <CR><LF> - command understood but not accessible at this moment  
n - parameter, decimal value determining filter number.  
n → 1 – very fast  
2 – fast  
3 – average  
4 – slow  
5 – very slow

#### Caution:

The numbering is assigned to a particular filter name and it is identical for all scale types. If for a particular scale type, filter settings are assigned to a working mode, the command changes the current mode's settings.

Example:

Command: FIS\_3<CR><LF> - set average filter  
 Response: FIS\_OK<CR><LF> - average filter set

**Give Scale Type**

Format: BN <CR><LF>

Response options:

BN\_A "x" <CR><LF> - command understood, response: weighing device type  
 BN\_I <CR><LF> - command understood but not accessible at this moment  
 x - scales series (inserted in between inverted commas), with general scale type in front.

Example:

Command: BN <CR><LF> - Return scale type  
 Response: BN\_A "AS" - Scale type XA 4Y

**Give status of inputs settings**

Format: GIN CR LF

Response:GIN\_XXXX CR LF - where: XXXXX- status of inputs settings starting from input 5 and ending with input 1 0-input not set 1-input set

Response format:

1	2	3	4	5-9	10	11
G	I	N	space	inputs status	CR	LF

**Inputs status**

-5 characters signalling inputs status: character No. 5 input 5 ...character No. 9 input 1

**Give status of outputs settings**

Format: GOUT CR LF

Response:GOUT\_XXXX CR LF - where XXXX-status of outputs settings starting from output 4 and ending with output 1 0-output not set 1-output set

Response format:

1	2	3	4	5	6-9	10	11
G	O	U	T	space	outputs status	CR	LF

**Outputs status**

-4 characters signalling outputs status: character No. 6 output 4 ...character No. 9 input 1

**Set Outputs**

Format: SOUT\_XXXX CR LF, where: \_ - space, XXXXX – outputs status setting active-1 or not active-0 starting from output No.4 to output No. 1.

Response options:

SOUT\_OK CR LF - command carried out  
 ES CR LF - command not recognised (incorrect outputs mask format )

**Internal Adjustment**

Format: **IC CR LF**

Response options:

- IC\_A CR LF - command understood and in progress
- IC\_D CR LF - adjustment completed
- IC\_A CR LF - command understood and in progress
- IC\_E CR LF - time limit exceeded while waiting for a stable measurement result
- IC\_I CR LF - command understood but not accessible at this moment

**Send module settings**

Format: **PS <CR><LF>**

Response options:

Example:

- Command: PS <CR><LF> - send module settings
- PS\_A<CR><LF>
- Response: ... - scale settings
- PS\_D<CR><LF>

## 6. Communication Cables, Power Supply

### 6.1. MWSH, MWLH Cables

RS232 cable: HRP-Computer

PT0348

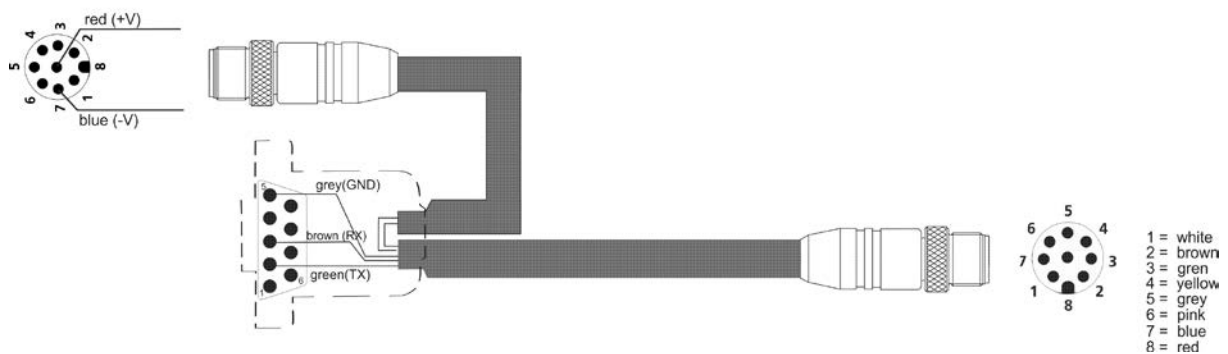

RS485 cable: HRP

PT0375

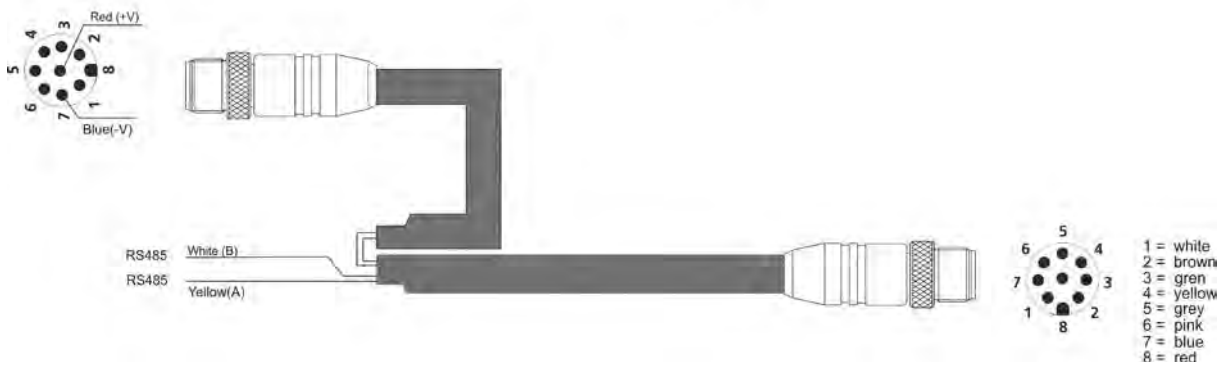

RS232 cable: HRP-HY10,PUE5 + power supply

PT0347

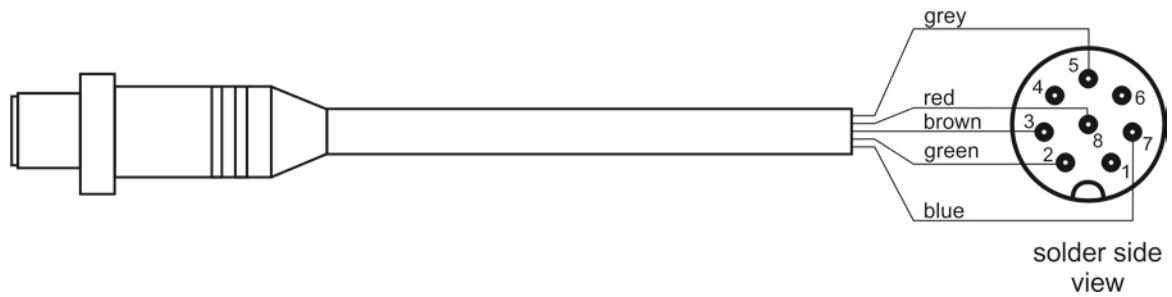

Ethernet cable: HRP-HY10,PUE5

PT0302

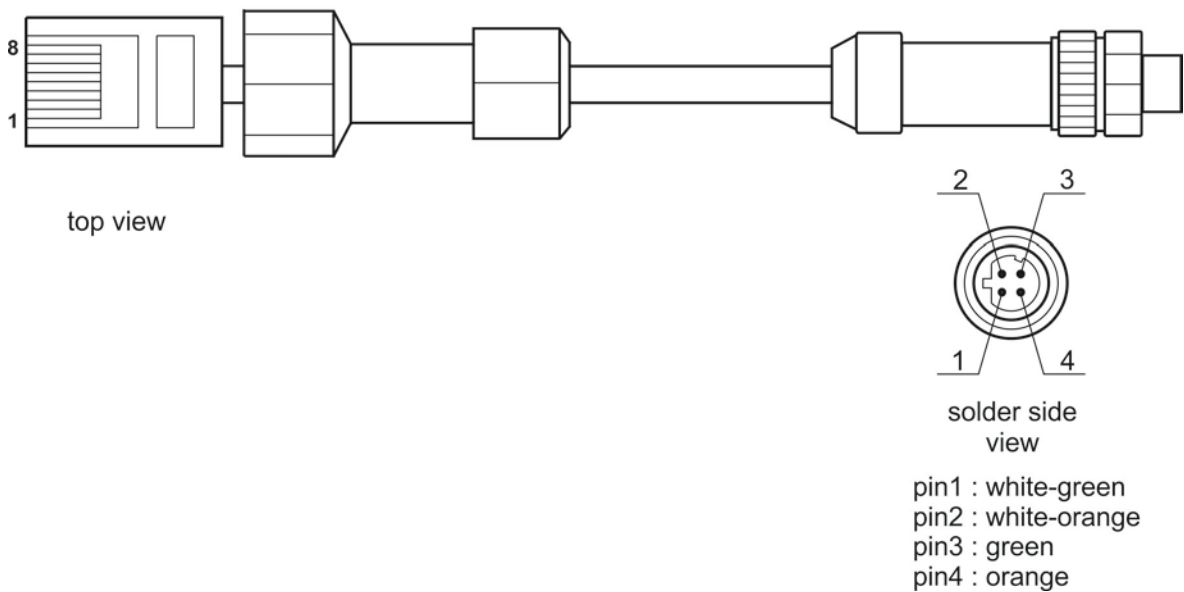

# PT0303

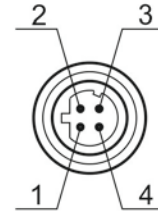
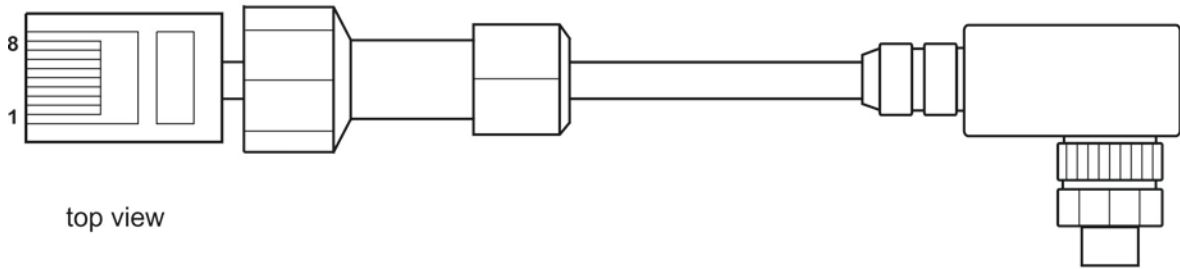

- pin1 : white-green
- pin2 : white-orange
- pin3 : green
- pin4 : orange

Ethernet cable: HRP-Ethernet Switch,Pue 7.1

# P0198

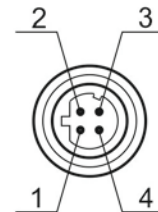
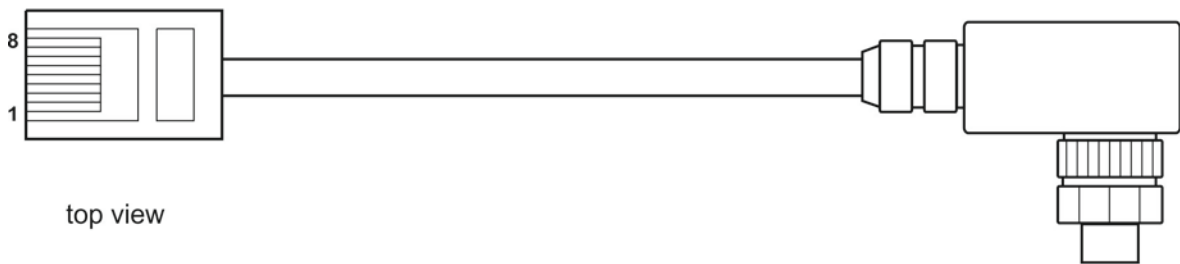

- pin1 : white-green
- pin2 : white-orange
- pin3 : green
- pin4 : orange

In/Out cable: HRP

PT0256



IN/OUT - HRP, MWSH, MWLH cable

**Caution:**

Colours of wires for cable of M12 standard. The figure presents exemplary cable type.

**6.2. MWSH, MWLH Power Supply**

To supply modules use SYS-1544-2415-T3-HRP power supply. In case of communication via PT0348 or PT0375 cables, the power supply has to be plugged to the connector that terminates the cable. In case of communication via Ethernet or Profibus, the power supply has to be plugged directly to the connector No. 3 .

**6.3. Diagrams of Connection Cables of MWMH**

**Version with Binder connectors**

RS232 + Ethernet Cable

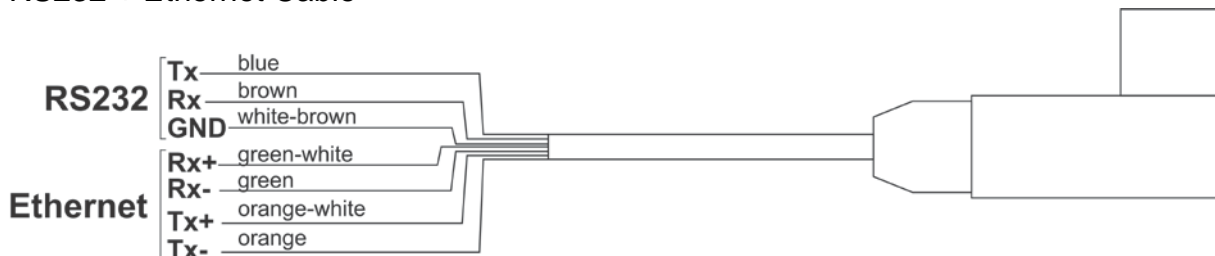

### IN/OUT + Power Supply Cable

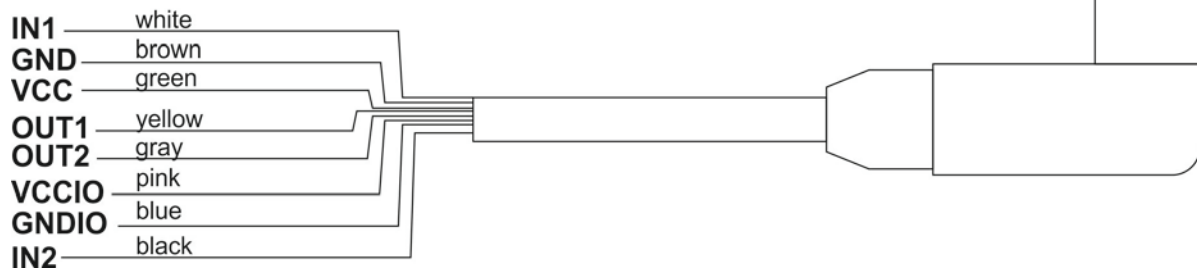

### Cable for connectors 3 and 4

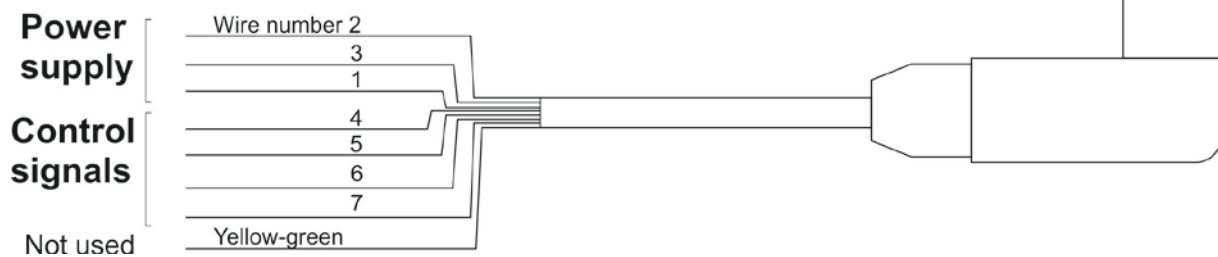

Maximum permissible voltage used to supply and control the device via cable connected to connectors 3 and 4 is 24V DC and 12V AC. Maximum current is 5 A for wires 1,3 and 2, and 200 mA for wires 4,5,6. Wires 1 and 3 are electrically connected inside of the module.

### Version with cables fed through cable glands.

Description of cables RS232+Ethernet and IN/OUT+Power supply is the same as in case of version equipped with connectors.

### Cable for connectors 3 and 4

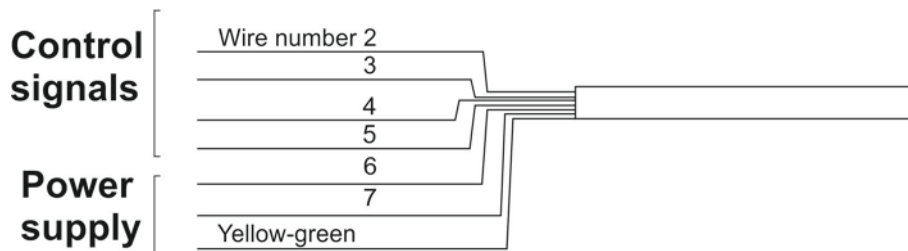

Maximum permissible voltage used to supply and control the device via cable fed through cable glands 3 and 4 is 24V DC and 12V AC. Maximum current is 5 A for wires 6 and 7,8, and 200 mA for wires 2,3,4 and 5. Wire 7 and yellow-green wire are electrically connected inside of the module.



## 7. Error Messages

-Err2-	Value out of zero range
-Err3-	Value out of tare range
-Err8-	Zeroing/taring time out of range
-NULL-	Zero value from converter
-FULL-	Measuring range (Max. capacity) exceeded
-LH-	Start mass error



**RADWAG BALANCES AND SCALES**  
ADVANCED WEIGHING TECHNOLOGIES

