

MW-01-A

MASS CONVERTER

USER MANUAL

ITKU-132-02-01-22-EN









 **RADWAG**®
RADWAG BALANCES AND SCALES
ADVANCED WEIGHING TECHNOLOGIES

JANUARY 2022

PRECAUTIONS

Prior to installation, operation or maintenance activities, carefully read this user manual. Follow the instructions strictly.

	Prior to the first use, carefully read this user manual. Use the device only as intended.
	Protect the device against considerable temperature variation, solar and UV radiation, substances causing chemical reactions.
	The device must not be operated in hazardous areas endangered with explosion of gases, and in dusty environments.
	In the case of damage, immediately unplug the device from the mains.
	The device to be decommissioned must be decommissioned in accordance with valid legal regulations.
	If the device is to be operated in conditions that are difficult due to electrostatics (e.g. printing house, packing centre, etc.), you must connect it to the earth wire. To enable this, the device features functional earthing terminal, marked with \perp symbol.

CONTENTS

1. INTENDED USE	5
2. WARRANTY CONDITIONS	5
3. MAINTENANCE	5
4. SERVICE AND REPAIR	6
5. RECYCLING	6
6. MECHANICAL DESIGN	6
6.1. General View	7
6.2. Dimensions	7
6.3. Connectors	7
6.4. RS232 Connector	8
6.5. Inputs/Outputs	8
6.5.1. Technical Specifications	9
6.6. Main Board Sockets	9
6.7. Technical Specifications	10
6.8. Models	11
7. INSTALLATION	11
7.1. Unpacking and Installation	11
7.2. START-UP	11
8. INSTALLER INSTRUCTION	11
8.1. 6-Wire Load Cell Connection	11
8.2. 4-Wire Load Cell Connection	12
8.3. Connecting Load Cell's Cable Shield	13
9. FACTORY PARAMETERS	14
9.1. Factory Parameter Access	14
9.2. Factory Parameters	15
9.3. Parameter Value Modification	16
9.4. Factory Adjustment	17
9.4.1. Start Mass Determination	17
9.4.2. Adjustment Factor Determination	17
9.5. Linearity Correction	18
9.6. Gcor	19
10. OPTIONAL EXTENSION MODULES	19
10.1. Exclusions Regarding Installation of Additional Modules	19
10.2. RS485 Module	20
10.2.1. RS485 Pins	20
10.3. ETHERNET Module	20
10.4. ETHERNET IP Module	21
10.5. Analog Output Module	22
10.5.1. Wiring Diagrams of the Current Loop Module	23
10.5.2. Technical Specifications	23
10.6. PROFIBUS Module	24
10.6.1. PROFIBUS Pin Arrangement	24
10.7. PROFINET Module	24
11. ACCESSORIES	25

1. INTENDED USE

The MW-01-A mass converter is designed to be a component of an industrial load cell scale. Depending on the needs, communication with the mass converter can be carried out via the following communication interfaces: RS232, RS485, Ethernet, Profibus, Profinet, Ethernet IP. The MW-01-A mass converter is compatible with indicators and PC.

Operation of the MW-01-A mass converter via PC is carried out using „**MwManager**” software.

2. WARRANTY CONDITIONS

- A. RADWAG is obliged to repair or exchange all elements that appear to be faulty by production or by construction.
- B. Defining defects of unclear origin and means of their elimination can only be realized with the assistance of the manufacturer and the user representatives.
- C. RADWAG does not bear any responsibility for damage or losses resulting from unauthorized or inadequate performing of production or service processes.
- D. The warranty does not cover:
 - mechanical damage caused by product exploitation other than intended, damage of thermal and chemical origin, damage caused by lightning, overvoltage in the power network or other random event,
 - inappropriate cleaning habits.
- E. Loss of warranty takes place if:
 - a repair is carried out outside RADWAG authorized service point,
 - service claims intrusion into mechanical or electronic construction by unauthorized people,
 - the device does not bear security seal stickers.
- F. Warranty conditions outline the warranty period for rechargeable batteries attached to the device for 12 months.
- G. For detailed warranty conditions read the service card.
- H. Contact with the central authorized service: +48 (48) 386 63 30.

3. MAINTENANCE

In order to clean the mass converter risk-free, it is necessary to disconnect the device from the mains.

Avoid using cleansers containing any corrosive chemicals, e.g. bleach (with chlorine). Do not use cleansers containing abrasive substances. Always remove the dirt using a microfiber cloth, do it to avoid damage to the protective coating. In the case of daily maintenance:

1. Remove the dirt using cloth dipped in warm water.
2. For best results, add a little bit of dishwashing detergent.

4. SERVICE AND REPAIR



In the case of any sign of damage, it is necessary to disconnect the device from the mains immediately. The damaged component must be replaced or repaired by RADWAG service directly.

In the case of any problems with correct operation of the device, contact the closest manufacturer's service point.

In the case of defects, deliver the faulty product to the manufacturer's service point. If the product cannot be delivered to the manufacturer's service point, call the service and report the defect. Repair scope and method will be set up.



The user is NOT ALLOWED to carry out any kind of repair of the device himself/herself. Any attempt of module modification, repair etc. by unauthorized persons, will result with loss of validity of manufacturer-issued certificates, declarations and warranty.

5. RECYCLING

The MW-01-A mass converters must be recycled, they are not to be treated as a regular household waste. Devices to be decommissioned must be decommissioned in accordance with valid legal regulations.



6. MECHANICAL DESIGN

The mass converter is equipped with metal housing. Depending on the MW-01-A model, the communication with external devices is carried out via the following communication interfaces: RS232, RS485, Ethernet, Profibus, Profinet, Ethernet IP. The module can be equipped with 3 digital inputs, 3 analog inputs and outputs such as current loop or voltage output. It is powered with 12÷24VDC voltage.

6.1. General View

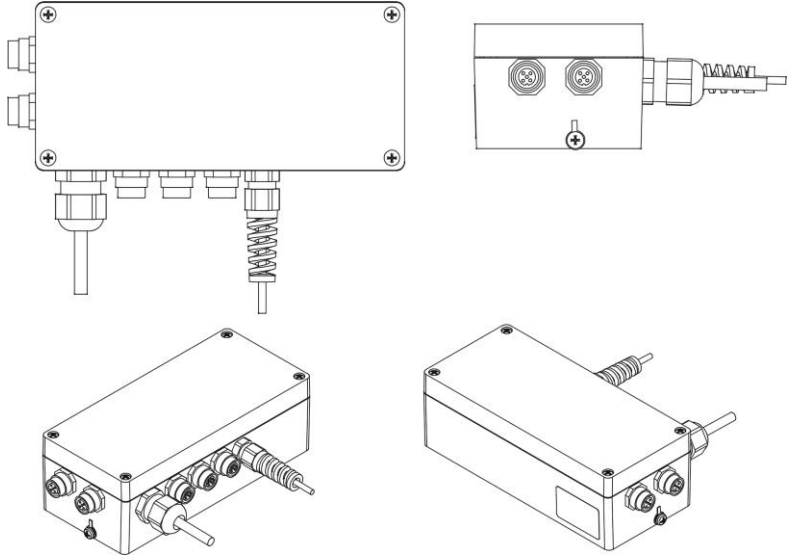

Figure 1. MW-01-A mass converter, general view

6.2. Dimensions

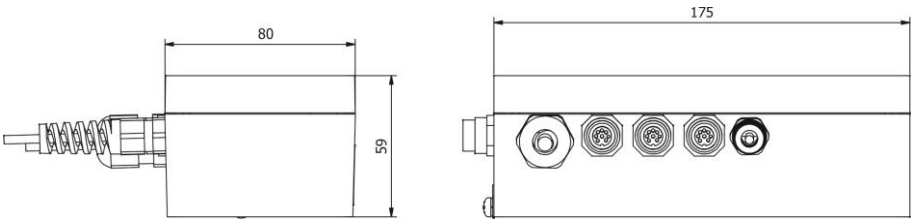

Figure 2. MW-01-A mass converter, dimensions

6.3. Connectors

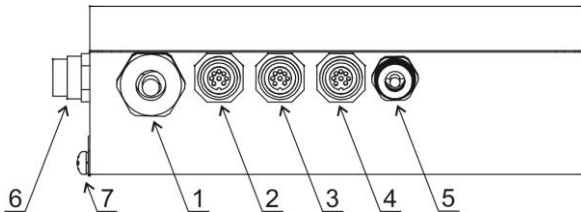
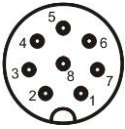

Figure 3. Arrangement of connectors

1	Platform cable gland
2	RS232 M12 8P connector
3	3IN M12 8P connector.
4	3IN M12 8P connector.
5	Power cord cable gland.
6	PROFIBUS connectors (interchangeably with ETHERNET, PROFINET and ETHERNET IP).

6.4. RS232 Connector

RS232		Pin1 – NC Pin2 – RxD Pin3 – TxD Pin4 – NC Pin5 – GND Pin6 – 5VDC Pin7 – NC Pin8 – NC
--------------	---	---

6.5. Inputs/Outputs

Standard MW-01-A mass converter is equipped with 3 optoisolated inputs and 3 semiconductor outputs (semiconductor relays). The signals are fed through M12 8P connectors.

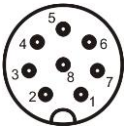
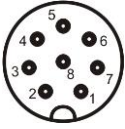
3IN		Pin1 – IN1 Pin2 – IN2 Pin3 – IN3 Pin4 – NC Pin5 – COMM Pin6 – VDC Pin7 – GND Pin8 – NC
3OUT		Pin1 – OUT1 Pin2 – OUT2 Pin3 – OUT3 Pin4 – NC Pin5 – COMM Pin6 – VDC Pin7 – GND Pin8 – NC

6.5.1. Technical Specifications

Output parameters	
Output quantity	3
Output type	Solid-state relay
Maximum output current	0.5 A DC
Maximum output voltage	30 VDC, AC
Input parameters	
Input quantity	3
Input type	Optoisolated
Input voltage range	5 - 24 VDC

6.6. Main Board Sockets

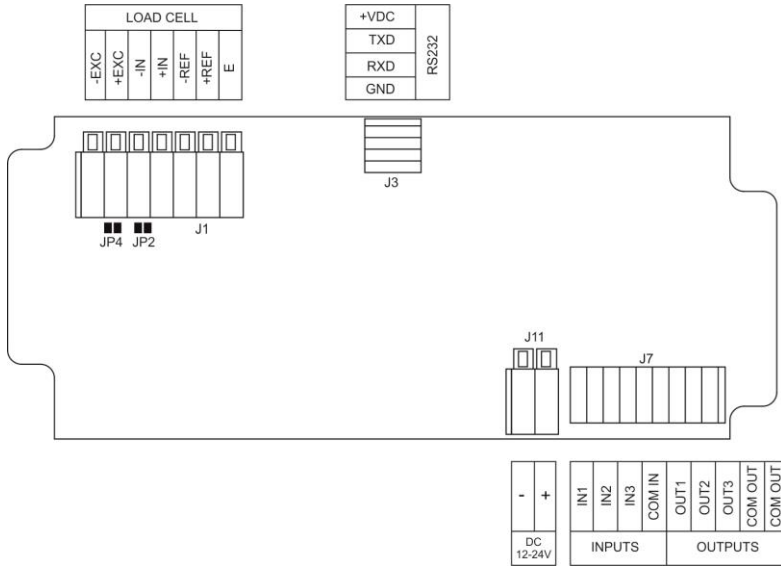

Figure 4. Arrangement and description of the main board (215R) sockets

6.7. Technical Specifications

Housing	Metal
Ingress protection	IP66
Power supply	12 ÷ 24 VDC
Operating temperature	-10 °C ÷ +40 °C
OIML class	III or IIII
Verification units	n≤10 000
Maximum input signal gain	19.5 mV
Maximum voltage per verification unit	1.95 µV
Minimum voltage per verification unit	0.5 µV
Minimum load cell impedance	50 Ω
Maximum load cell impedance	1200 Ω
Load cell excitation voltage	5 VDC
Load cell connection	4 or 6 wires + SHIELD
Platform quantity	1
Multi-range option	Yes
Standard interfaces	
RS232	M12 8P connector
3IN	M12 8P connector
3OUT	M12 8P connector
Optional interfaces	
RS485	M12 8P connector
Ethernet	RJ45 interface
PROFINET	RJ45 interface
ETHERNET IP	RJ45 interface
PROFIBUS	2 x M12 5P connector
Analog outputs 4-20 mA, 0-10 V	M16 cable gland

6.8. Models

There are seven models of the MW-01-A mass converter:

- MW-01-A1: standard design (RS232 + IN/OUT),
- MW-01-A2: standard design + Ethernet,
- MW-01-A3: standard design + RS485,
- MW-01-A4: standard design + Profibus,
- MW-01-A5: standard design + Profinet,
- MW-01-A6: standard design + Ethernet IP,
- MW-01-A7: standard design + Analog output.

7. INSTALLATION

7.1. Unpacking and Installation

- A. Take the mass converter out of the packaging.
- B. Connect the weighing platform to the mass converter, next place the device on a flat and even surface. Keep it away from any sources of heat.
- C. Level the device.



Levelling procedure is to be found in 'TWM1 Scale' user manual.

7.2. START-UP

- Plug the power supply to the mains.
- Wait for connection to be established between the mass converter and the **'MwManager'** software, read the weighing result.



The procedure of communication establishing and a detailed description of connection between the scale and the 'MwManager' software is to be found in the software user manual.

8. INSTALLER INSTRUCTION

The MW-01-A mass converter can be a base component of a load cell scale.

8.1. 6-Wire Load Cell Connection

Connect 6-wire load cell to the main board following the diagram below:

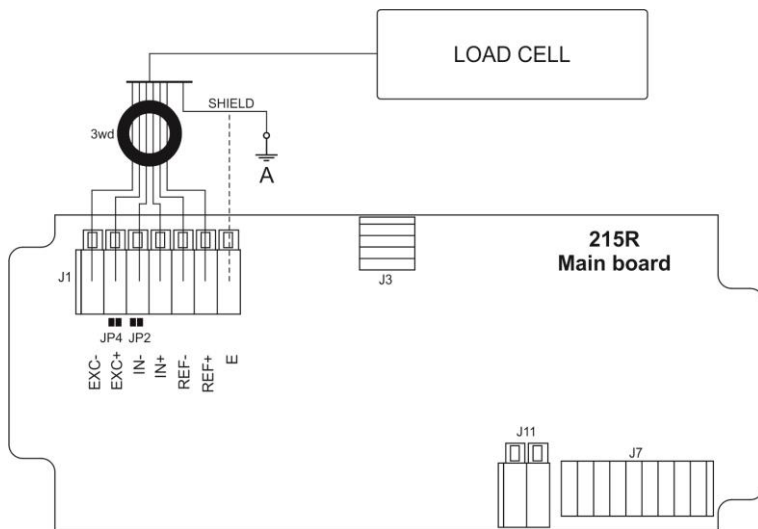

Figure 5. Connecting 6-wire load cell

Socket	Load cell signal	REMARKS
E	SHIELD	Refer to section 8.3
REF+	SENSE +	JP2 not to be soldered
REF-	SENSE -	JP4 not to be soldered
IN+	OUTPUT+	
IN-	OUTPUT-	
+EXC	INPUT+	
-EXC	INPUT-	

8.2. 4-Wire Load Cell Connection

Connect 4-wire load cell to the main board following the diagram below:

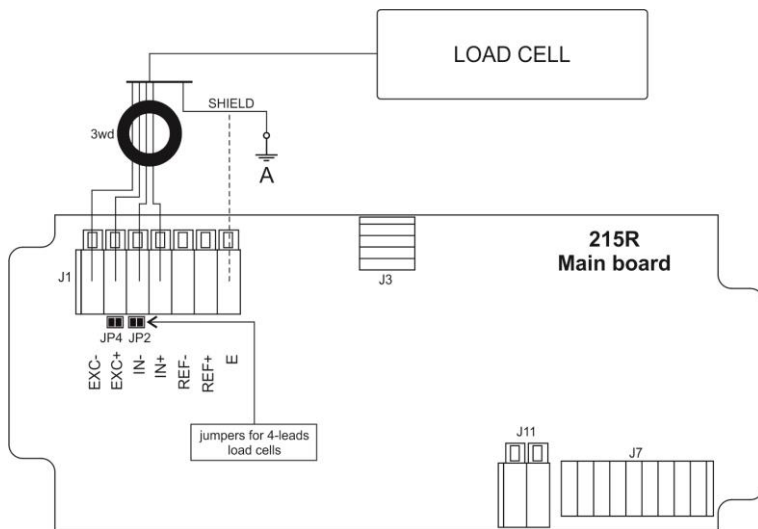

Figure 6. Connecting 4-wire load cell

Socket	Load cell signal	REMARKS
E	SHIELD	Refer to section 8.3
REF+	-	JP2 soldered
REF-	-	JP4 soldered
IN+	OUTPUT+	
IN-	OUTPUT-	
+EXC	INPUT+	
-EXC	INPUT-	

8.3. Connecting Load Cell's Cable Shield

	Scale with a mass converter in a metal housing connected with a platform via a load-cell signal cable.	Scale of compact mechanical design, mass converter in a metal housing connected with a platform via an extension arm, etc.
Platform without galvanic connection of the signal cable's shield	POINT A	E
Platform with galvanic connection of the signal cable's shield	POINT A	POINT A

Point A – electrical connection with the housing.
E – solder pad on A/D converter board.

9. FACTORY PARAMETERS

In order to be able to edit and save factory parameters to the MW-01-A mass converter's memory, it is necessary to put a jumper allowing access to the factory parameters.

9.1. Factory Parameter Access

- Plug the power supply of the MW-01-A mass converter to the mains.
- Press internal micro switch, **SW1**:

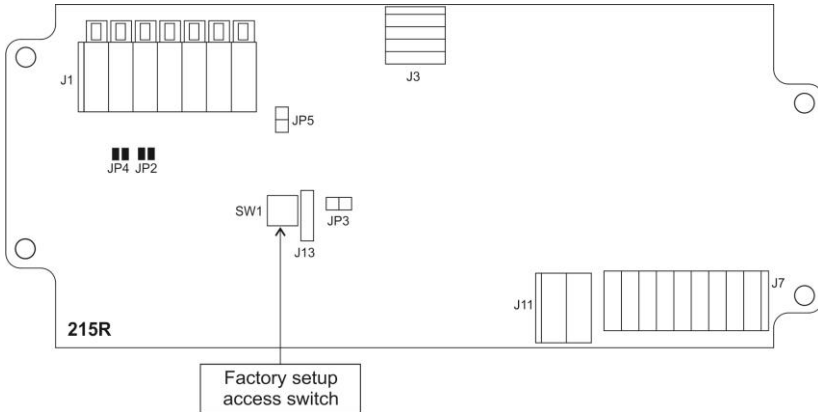

Figure 7. Factory parameters' access switch

- Wait for connection to be established between the mass converter and the **'MwManager'** software, go to **<Parameters / Factory parameters>** submenu.
- Factory parameters are set into groups: Adjustment, Weighing, Information, Converter. To access a given group, select a respective tab.

Factory parameters

Calibration | Linearity | Weighing | Information | Converter



Full range [kg] 1st range division

2nd range threshold [kg] 2nd range division

3rd range threshold [kg] 3rd range division

Calibration weight [kg] Calibration unit

Verified

Adjust start mass  Adjust calibration factor 

 Set defaults





 Refresh  Read from file  Save to file  Save

Figure 8. Factory parameters window

9.2. Factory Parameters

NAME	DEFAULT	VALUES	REMARKS
Adjustment	-	-	-
Range	3.009	-	Maximum range + 9e overload.
Range 2 threshold	0	-	Switching point of range II. For single range balances set 0 .
Range 3 threshold	0	-	Switching point of range III. For I-range or II-range scales set 0 value.
Reading unit: range 1	0.001	0,001 ÷ 50	Rounding of the last digit and position of a decimal point for weighing range I.
Reading unit: range 2	0.001	0,001 ÷ 50	Rounding of the last digit and position of a decimal point for weighing range II.
Reading unit: range 3	0.001	0,001 ÷ 50	Rounding of the last digit and position of a decimal point for weighing range III.
Adjustment weight	3	-	Adjustment weight mass.
Adjustment unit	kg	g, kg, lb	Adjustment (calibration) unit.
Verified	NO	YES - NO	Declaring whether the scale is verified or not. YES - verified scale, NO - non-verified scale.

Determine start mass	-	-	Start mass determination (refer to section 9.4.1).
Determine adjustment factor	-	-	Adjustment factor determination (read section 9.4.2).
Set defaults	-	-	Restoring default adjustment parameter settings.
Linearity	-	-	Section linearity correction (refer to section 9.5).
Weighing	-	-	-
Autozero range	0.25	0.1 ÷ 5	Autozero range (in divisions).
Stability range	1	0.1 ÷ 5	Stability range in [d] units.
Stability time	0.8	0.1 ÷ 5	Stability time, given in seconds.
Start mass control	1	0, 1, 2	Start mass control: 0 – disabled, 1 – range: from -5% to +15% of start mass, 2 – range: from -20% to +20% of start mass.
Information	-	-	-
A/D divisions	-	-	Current quantity of converter divisions.
Adjustment factor	100	-	Adjustment/calibration factor.
Start mass	100	-	Start mass value (in divisions).
Gcor	1	-	Gravitational correction factor (refer to section 9.6).
Serial number	-	-	Serial number of the mass converter.
Adjustment qty counter	-	-	The quantity of factory parameter recordings.
Factory start mass	100	-	Start mass value expressed in converter's divisions, read in the course of the factory adjustment.
Factory adjustment factor	100	-	Adjustment factor value, determined during the factory adjustment.
Converter	-	-	-
Converter rate	6,25	6.25 ÷ 1600	Converter rate change.

9.3. Parameter Value Modification

- Select a parameter, enter/modify its value.
- Press **<Save>** button, message **<Save parameters?>** is displayed.
- Press **<Yes>** button to confirm, message **<Changes saved>** is displayed.
- Press **<OK>** button to confirm.

9.4. Factory Adjustment

9.4.1. Start Mass Determination

- Unload the weighing pan.
- Go to **<Adjustment>** tab, press **<Determine start mass>** button, message **<Unload the pan>** is displayed.
- Press **<OK>** button to confirm, start mass adjustment begins.
- Upon completion, message: **<Start mass determination completed successfully>** is displayed.
- Press **<OK>** button to confirm.
- Press **<Save>** button, message: **<Save parameters?>** is displayed.
- Press **<Yes>** button to confirm, message **<Changes saved>** is displayed.
- Press **<Yes>** button to confirm. Determined start mass gets saved to converter's memory.

9.4.2. Adjustment Factor Determination

- Unload the weighing pan.
- Press **<Determine adjustment factor>** button, message: **<Unload the pan>** is displayed.
- Press **<OK>** button to confirm, start mass determination begins.
- Upon completion, message: **<Load xxx>** (where: xxx – declared adjustment weight mass) is displayed.
- Load the weighing pan with weight of the specified mass value and press **<OK>** button.
- Upon completion, message: **<Adjustment factor determination completed successfully>** is displayed.
- Press **<OK>** button to confirm.
- Press **<Save>** button, message: **<Save parameters?>** is displayed.
- Press **<Yes>** button to confirm, message **<Changes saved>** is displayed.
- Press **<Yes>** button to confirm. Determined adjustment factor gets saved to mass converter's memory.

9.5. Linearity Correction

„Linearity” tab enables access to thresholds and linearity deviations.

Factory parameters

Calibration | **Linearity** | Weighing | Information | Converter

Threshold		Deviation		
1	[kg]	0.0081	[kg]	
2	[kg]	0.0085	[kg]	
0	[kg]	0	[kg]	
0	[kg]	0	[kg]	
0	[kg]	0	[kg]	
0	[kg]	0	[kg]	

Zero thresholds while zeroing linearity

Zeroing limit

Refresh | Read from file | Save to file | Save

Figure 9. Linearity correction window

Where:

	Press to zero all threshold values. To zero the deviations and the thresholds, select <Zero thresholds while zeroing linearity> option.
	Press to zero a value of a particular threshold/deviation.
	Press to determine deviation of a particular threshold.

Procedure:

- Enter linearity threshold values.
- Press particular threshold button, , message **<Load xxx>** (where: xxx – entered mass value) is displayed.
- Load the weighing pan with weight of the declared mass value and press **<OK>** button.
- Deviation is calculated automatically and entered in the linearity threshold deviation field.
- Determination of deviations for remaining linearity thresholds proceeds analogously.

- Press **<Save>** button to save changes, message **<Save parameters?>** is displayed.
- Press **<Yes>** button to confirm, message **<Changes saved>** is displayed.
- Press **<Yes>** button to confirm.

9.6. Gcor

The function of gravitational correction compensates changes of earth gravity being a result of different latitude. It enables correct calibration of the weighing device away from the place of use. The gravitational correction value must be entered with reference to tables prepared by „Radweg Wagi Elektroniczne” or calculated using the below formula:

$$G_{cor} = \frac{g_{uzyt.}}{g_{kal.}}$$

Correction value ranges between 0.90000 ÷ 1.99999.

	<p><i>If the scale is calibrated at the place of use, then the gravitational correction value (<g-cor.> parameter) is 1.00000. If the scale is calibrated away from the place of use (longitudinal change), the value of <g-cor.> parameter must be corrected.</i></p>
---	---

10. OPTIONAL EXTENSION MODULES

The MW-01-A mass converter can be equipped with additional optional interface modules: ETHERNET, RS485, PROFIBUS, PROFINET, ETHERNET IP and analog outputs (4-20 mA or 0-10 V). The modules are installed inside the device. Optional interfaces are installed interchangeably.

10.1. Exclusions Regarding Installation of Additional Modules

INSTALLED MODULE	EXCLUDED MODULES
ETHERNET	RS485, PROFIBUS, ETHERNET IP, PROFINET
PROFIBUS	RS485, ETHERNET, ETHERNET IP, PROFINET
PROFINET	RS485, PROFIBUS, ETHERNET IP, ETHERNET
RS485	ETHERNET, PROFIBUS, ETHERNET IP, PROFINET

10.2. RS485 Module

The 309R module, expanding the functionality of the MW-01-A converter by RS485 interface, is installed on an intermediate board, 385R ver. B. The module is intended to be mounted inside the MW-01-A. For the 309R module, an extra M12 8P connector is installed on the housing.

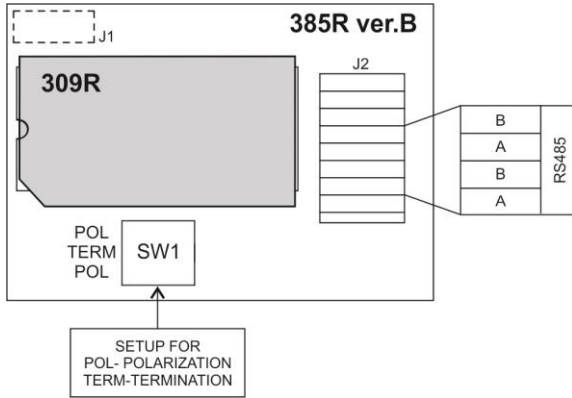

Figure 10. RS485 module

10.2.1. RS485 Pins

RS485		<ul style="list-style-type: none"> Pin1 – B Pin2 - NC Pin3 – A Pin4 – A Pin5 – NC Pin6 - NC Pin7 – B Pin8 – NC
-------	--	--

10.3. ETHERNET Module

The 570R module expands the functionality of the MW-01-A converter by Ethernet interface. The module is intended to be mounted inside the MW-01-A. For the 494R module, a hermetic RJ45 connector is installed on the housing.

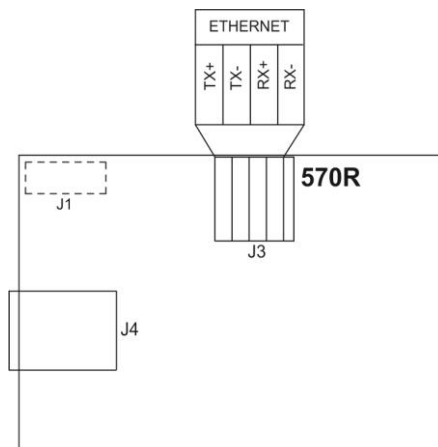

Figure 11. ETHERNET 570R module

10.4. ETHERNET IP Module

The 494R module, combined with AB6003 module, expands the functionality of the MW-01-A converter by Ethernet IP interface. The module is intended to be mounted inside the indicator. For the 494R module, a hermetic RJ45 connector is installed on the housing.

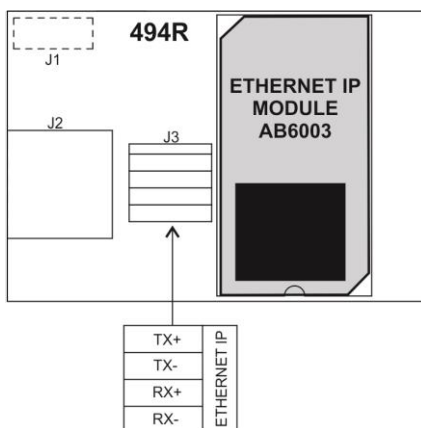

Figure 12. ETHERNET IP module

10.5. Analog Output Module

The 495 R module expands the functionality of the MW-01-A converter by an analog output, 4-20 mA, and a voltage output, 0-10 V. The module is intended to be mounted inside the MW-01-A. The 495R module is a passive module. The MW-01-A converter's housing features a cable gland through which a 3-metre cable 6x0.34 mm² is fed, which cable is terminated with isolated wires.

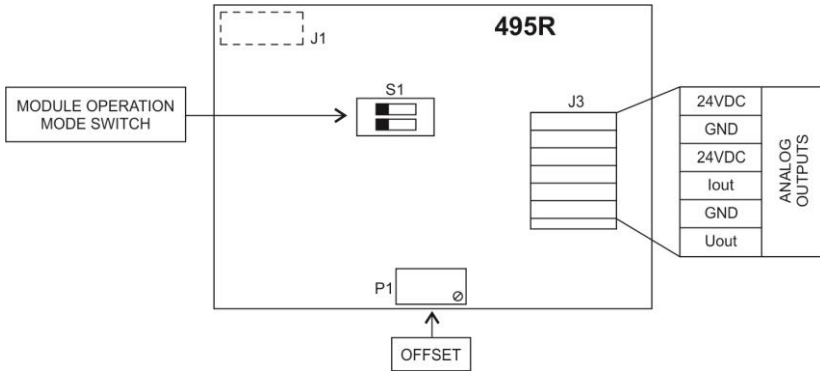

Figure 13. 495R current loop module

The module's working mode is set using **S1** switch, when setting the module's working mode refer to the below table.

R1	R2	WORKING MODE
0	0	0-10 V
1	0	4-20 mA
0	1	0-20 mA
1	1	0-24 mA

Analog output module board provides description of settings, for the description look around **S1** switch.

BY DEFAULT, SET THE ANALOG OUTPUT MODULE TO 4-20 mA MODE.

Analog output must be calibrated (adjusted); using P1 potentiometer set the correct offset (e.g., for 4 - 20 mA output, adjust current so that for 0 kg indication it is precisely 4 mA). In the case of remaining operation modes proceed analogously.

10.5.1. Wiring Diagrams of the Current Loop Module

Voltage output wiring diagram

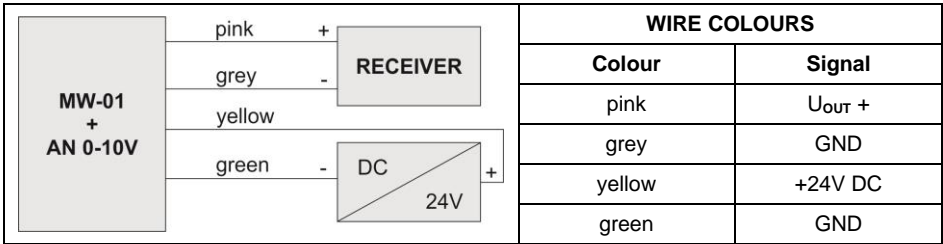

Current output wiring diagram

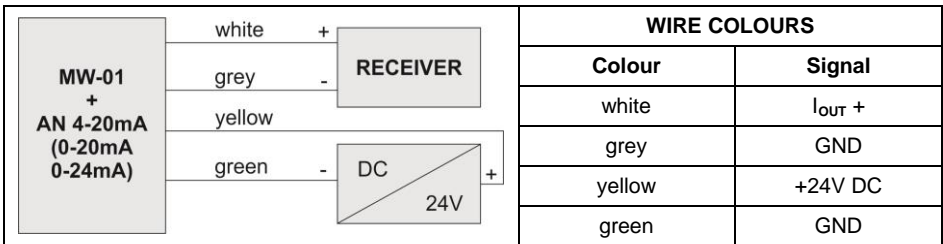

10.5.2. Technical Specifications

Output resolution	16bit
Linearity error	+/- 0.01 %
4 mA indication error	+/- 0.1 %
Temperature error for 4 mA	+/- 25 ppm/C
20 mA indication error	+/- 0.1%
Temperature error for 20 mA	+/- 25 ppm/C
Current loop power supply	24 VDC +/- 15 %
Power loss	450mW
Maximum loop resistance	500 ohm
Operating temperature	-10 °C ÷ + 40 °C

10.6. PROFIBUS Module

The AB6000 module, expanding the functionality of the MW-01-A converter by PROFIBUS interface, is installed on an intermediate board, 385R ver. A. The module is intended to be mounted inside the MW-01-A. For the AB6000 module, an extra M12 5P connector is installed on the housing (with coding respective for the PROFIBUS standard).

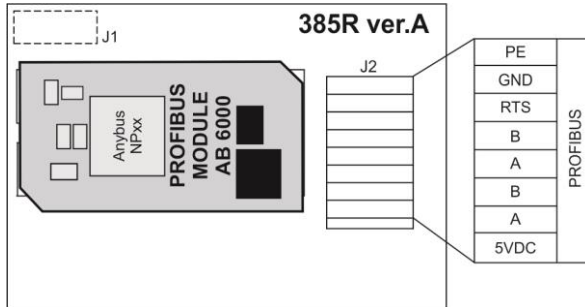

Figure 14. PROFIBUS module

10.6.1. PROFIBUS Pin Arrangement

<p>PROFIBUS IN (male)</p>		<p>Pin1 – NC Pin2 – A Pin3 – NC Pin4 – B Pin5 – NC</p>
<p>PROFIBUS OUT (female)</p>		<p>Pin1 - +5V Pin2 – A Pin3 – GND Pin4 – B Pin5 – NC</p>

10.7. PROFINET Module

The 494R module, combined with AB6005 module, expands the functionality of the MW-01-A converter by Profinet interface. The module is intended to be mounted inside the indicator. For the 494R module, a hermetic RJ45 connector is installed on the housing.

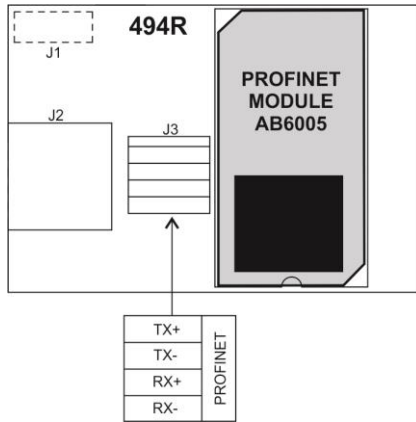

Figure 15. Profinet Module

11. ACCESSORIES

MW-01-A – computer cable	PT0020
MW-01-A – Ethernet cable	PT0212
MW-01-A – 3IN cable	PT0256
MW-01-A – 3OUT cable	PT0256
MW-01-A – RS485 cable	PT0383



RADWAG BALANCES AND SCALES
ADVANCED WEIGHING TECHNOLOGIES

