



[radwag.com](https://radwag.com)

Scan the QR code to view additional scientific material that may be of interest to you.  
There you will find more useful information in an accessible format!

# User manual

ITKU-136-02-05-24-EN





## IM02

Communication module

MAY 2024

## SAFETY PRECAUTIONS

Before you start installing, using or maintaining the device, you must read this operating manual and follow its guidelines.

	Before use, please read this operating manual carefully and use the device as per intended use.
	Protect the device against excessive temperature fluctuations, solar and UV radiation, and chemical substances.
	The device must not be exposed to gas or dust explosion risk.
	In case of failure, unplug the device immediately.
	The device to be withdrawn from service must be disposed of in accordance with currently applicable rules of law.

# Table of contents

<b>1. INTENDED USE</b> .....	<b>5</b>
<b>2. TERMS OF GUARANTEE</b> .....	<b>5</b>
<b>3. CLEANING</b> .....	<b>6</b>
<b>4. SERVICING AND REPAIRS</b> .....	<b>6</b>
<b>5. DISPOSAL</b> .....	<b>7</b>
<b>6. DESIGN</b> .....	<b>7</b>
6.1. View of main pieces of the module housing.....	7
6.2. Outside view - dimensions .....	7
6.3. Location of information labels.....	8
6.4. Technical parameters .....	8
6.5. Manufacture variants .....	9
6.6. Description of connectors (ports) .....	9
6.7. Arrangement of ports.....	10
6.8. 4IN/4OUT.....	11
6.8.1. Technical specification .....	11
6.8.2. 4WE/4WY schematic diagrams .....	11
6.9. Analogue output module.....	11
6.9.1. Technical specification .....	12
6.9.2. 4-20mA current output connection diagram .....	12
6.10. RS485 module.....	12
6.11. PROFIBUS module .....	12
6.12. PROFINET module .....	12
6.13. EtherNet/IP module.....	13
<b>7. INSTALLATION AND ACTIVATION</b> .....	<b>13</b>
7.1. Supplying power to the IM02 communication module .....	13
7.2. Connection of the IM02 communication module to the weighing terminal .....	13
7.3. Configuration of the IM02 communication module.....	13
<b>8. CONNECTION WIRE DIAGRAMS</b> .....	<b>13</b>

## 1. INTENDED USE

The IM02 communication module is an accompanying device that cooperates with PUE C10 terminals and 5Y-series balances. RS 232 (IOIOI port) serves as a communication interface to be connected to PUE C10 terminals and 5Y-series balances.

The IM02 communication module allows cooperation of PUE C10 terminals and 5Y-series balances with such accessories as barcode scanners, printers, external mass displays, control keys, light columns, buzzers, PLC controllers and other control and signalling equipment, as well as PCs.



In its standard design, the IM02 communication module is equipped with a 3 x RS232 port, Virtual COM (USB B-type), 4WE/4WY.

## 2. TERMS OF GUARANTEE

- A. RADWAG undertakes to repair or replace the pieces that prove defective in terms of manufacture or structure.
- B. It is allowed to specify defects of unclear origin and establish elimination methods only in cooperation with representatives of the manufacturer and user.
- C. RADWAG shall not be held responsible for any damage or loss arising from unauthorised or incorrect manufacture or servicing.
- D. The guarantee does not cover the following:
  - mechanical damage caused by wrong operation, as well as thermal and chemical damage, damage caused by atmospheric discharge, overvoltage in the power network or other random event,
  - maintenance works (cleaning).
- E. The guarantee cover is lost when:
  - an unauthorised service centre makes a repair,
  - the service technician identifies unauthorised interference in the mechanical or electronic structure,
  - rating plates of the device are missing or damaged.
- F. Detailed terms of the guarantee can be accessed in the service sheet.
- G. To contact the Authorised Service Centre, dial +48 (48) 386 63 30.

### 3. CLEANING

Before you start cleaning, unplug the communication module. To clean, use ordinary household cleaning agents.

	<p><b><i>In order to minimise the electrostatic discharge risk, clean the housing with a wet cloth. It is very important when the communication module is in a dry place. Moisture secures against accumulation of electrostatic charge.</i></b></p>
	<p><b><i>To clean the communication module, do not use sharp cleaning items, concentrated acids, bases, solvents and alcohol.</i></b></p>
	<p><b><i>It is forbidden to use compressed air to clean the communication module.</i></b></p>

### 4. SERVICING AND REPAIRS

	<p><b><i>If any damage is visible, unplug the device immediately. Have the damaged piece replaced or repaired by RADWAG service technician immediately.</i></b></p>
---	---

In case of any doubts concerning use or operation of the module, please contact the manufacturer's service centre.

In case of any defects, the user must deliver the defective device to the manufacturer's service centre or, when impossible, report the defect to the service technician to arrange the scope and method of repair.

	<p><b><i>The user is prohibited from making any repairs. Any interference (modifications at variance with the manual, repairs, etc.) in the module structure by people unauthorised by RADWAG shall invalidate the manufacturer's certificates, declarations and guarantees.</i></b></p>
---	--

## 5. DISPOSAL

IM02 modules can be recycled and are not considered as household waste. The product must be disposed of after the end of use in accordance with applicable rules of law.



## 6. DESIGN

### 6.1. View of main pieces of the module housing

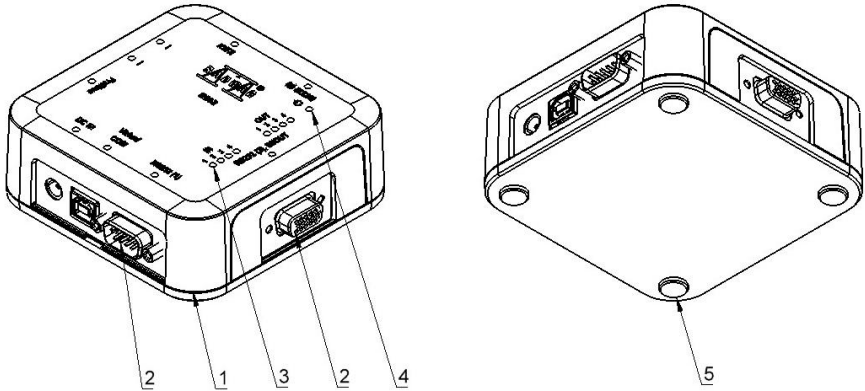

*Fig. 1. The view of main pieces of the module housing*

- 1. Housing.
- 2. Interface connectors (ports).
- 3. In/Out signalling LED lights.
- 4. Power signalling LED light.
- 5. Feet.

### 6.2. Outside view - dimensions

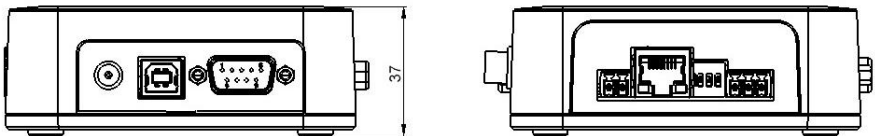

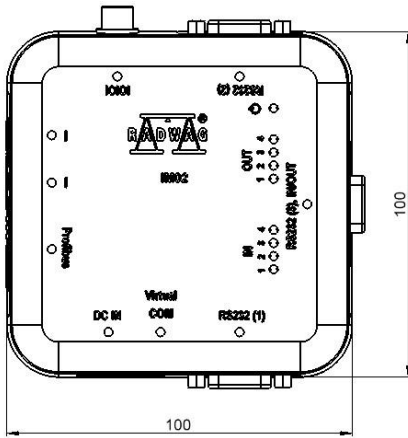

Fig. 2. The outside view - dimensions

### 6.3. Location of information labels

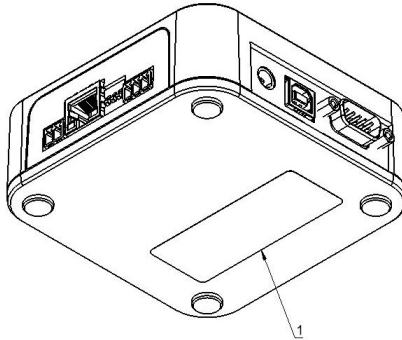

Fig. 3. The location of information labels

1 – Rating plate.

### 6.4. Technical parameters

	<b>IM02</b>
Housing	Plastic
Protection as per PN-EN 60529	IP43
Power supply	12±20 VDC
Ambient temperature	-20°C ÷ 40°C
Relative air humidity	10÷85% RH without condensation

## 6.5. Manufacture variants

The IM02.\* communication module (where \* means the version) is available in the following variants:

1	Standard: RS232 (1), RS232 (2), RS232 (3), 4IN/4OUT, Virtual COM
2	Standard + Analogue output 4-20mA
3	Standard + ProfiBus
4	Standard + RS485
5	Standard + EtherNet/IP
6	Standard + ProfiNet

## 6.6. Description of connectors (ports)

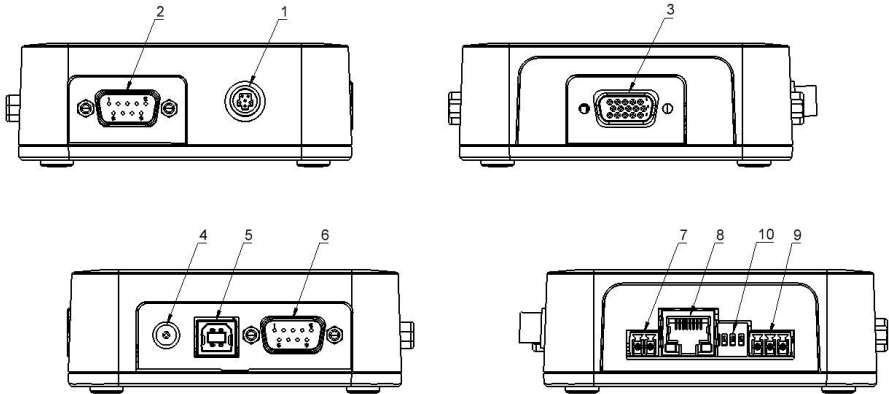
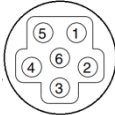
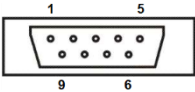
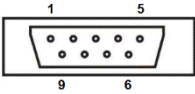
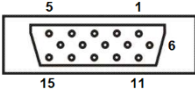

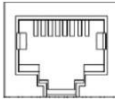
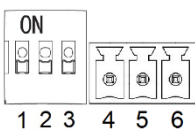
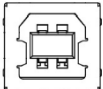



Fig. 4. The description of IM02 communication module ports

1	PUE10 (5Y) or PUE CY10 terminal port
2	RS232 (2) port
3	RS232 (3), IN/OUT port
4	DC (12V DC) power port
5	Virtual COM port
6	RS232 (1) port
7	Analogue OUT port – analogue output AN 4-20mA (option)
8	PROFINET or EtherNet/IP port (option)
9	PROFIBUS or RS485 port (option)
10	Polarisation and terminator switch - ProfiBus / RS485 (option)

### 6.7. Arrangement of ports

IOIOI		<p>1 - TxD                  2 - RxD                  4 - GND                  5 - in 12-20V                  6 - GND</p>
RS 232 (1)		<p>RS232 - DB9/M port (male):                  2 - RxD1                  3 - TxD1                  4 - 5V(DTR)                  5 - GND</p>
RS 232 (2)		<p>RS232 - DB9/M port (male):                  2 - RxD2                  3 -TxD2                  4 - 5V(DTR)                  5 - GND</p>
RS 232 (3) IN/OUT		<p>RS232, IN/OUT - DSUB15/F port (female),                  Pin1 - GNDIN                  Pin2 - OUT1                  Pin3 - OUT2                  Pin4 - COMM                  Pin6 - IN4                  Pin7 - IN3                  Pin8 - TxD3                  Pin9 - 5VDC                  Pin10 - GND                  Pin11 - IN2                  Pin12 - IN1                  Pin13 - RxD3                  Pin14 - OUT4                  Pin15 - OUT3</p>
4-20mA		<p>1 - +L                  2 - -L</p>
EtherNet/IP Profinet		<p>RJ45 port</p>
Profibus RS485		<p>1 - polarisation –                  2 - terminator                  3 - polarisation +                  4 – A                  5 – B                  6 - RTS</p>
USB B		<p>USB B-type port</p>

Optional power supply		1 "+" 12-20 DC 2 "-" 12-20 DC
-----------------------	---	----------------------------------

## 6.8. 4IN/4OUT

The IM02 communication module is optionally equipped with a 4IN/4IN module. The 4WE/WY module is supplied with optoisolated inputs and optoisolated OptoMOS relays. It allows you to freely configure inputs and outputs (from the menu of the PUE CY10 weighing terminal / 5Y-series balance). The signals are output to DSUB15/F port (female).

### 6.8.1. Technical specification

Output parameters	
Number of outputs	4
Type of outputs	Optoisolated OptoMOS relay
Max. switching current	0,45A DC
Max. forward voltage	50V DC, 30V AC
Input parameters	
Number of inputs	4
Type of inputs	Optoisolated
Control voltage range	12 -24V DC

### 6.8.2. 4WE/4WY schematic diagrams

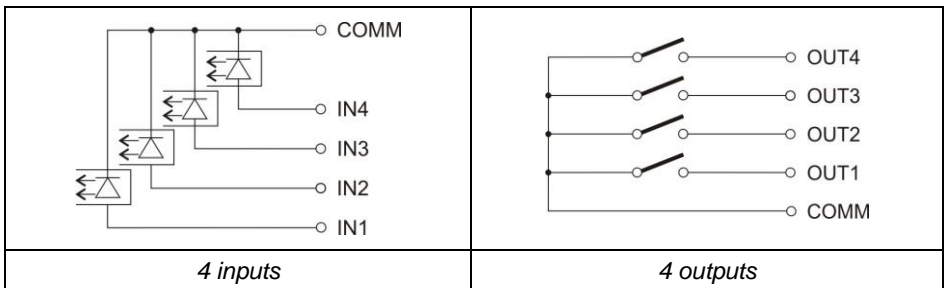

## 6.9. Analogue output module

The IM02 communication module is optionally supplied with an analogue output module. The analogue output module has a 4-20mA working mode (current-loop output 4-20mA).

### 6.9.1. Technical specification

Working modes	4 - 20mA
Module power supply	Power adapter in the loop 12-30V DC, max 20mA

### 6.9.2. 4-20mA current output connection diagram

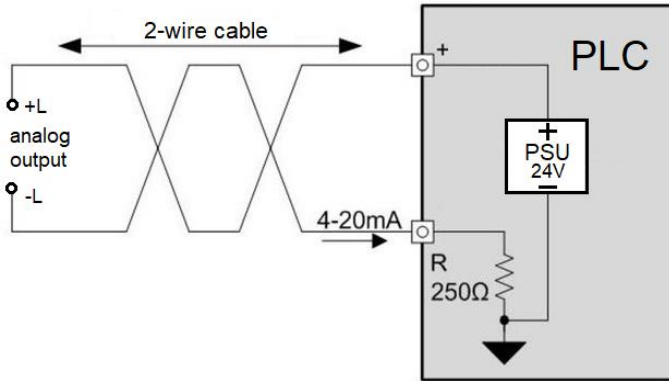

### 6.10. RS485 module

The IM02 communication module is optionally equipped with a RS485 interface. A and B line signals go to 3.81mm signal ports. The interface is configured via the DipSwitch switch. Polarisation is enabled through a switch no. 1 and 3, while terminator 120Ω through a switch no. 2.

### 6.11. PROFIBUS module

The IM02 communication module is optionally equipped with the PROFIBUS interface. A, B and RTS line signals are transmitted to 3.81mm signal ports. The interface is configured via the DipSwitch switch. Polarisation is activated with the switch no. 1 and 3, while terminator 120Ω with the switch no. 2.

### 6.12. PROFINET module

The IM02 communication module is optionally equipped with the PROFINET interface. The PROFINET interface is available in the RJ45 port.

### 6.13. EtherNet/IP module

The IM02 communication module is optionally equipped with the EtherNet/IP interface. The EtherNet/IP interface is available in the RJ45 port.

## 7. INSTALLATION AND ACTIVATION

Before you install and activate the device, please read this Operating Manual and use the equipment as designed.

The manufacturer is not held responsible for damage arising from wrong installation of the device and use at variance with the intended use.

### 7.1. Supplying power to the IM02 communication module

The IM02 communication module is supplied through a dedicated PT0454 cable that connects it to the PUE CY10 weighing terminal or 5Y-series balance. Active connection of the IM02 communication module to the power supply is indicated by the lighting of the LED marked with the symbol .

### 7.2. Connection of the IM02 communication module to the weighing terminal

The IM02 communication module is equipped with an IOIOI port used to connect the PUE CY10 weighing terminal or 5Y-series balance via the dedicated PT0454 cable.

### 7.3. Configuration of the IM02 communication module

The IM02 communication module is configured in the application in the PUE CY10 weighing terminal or 5Y-series balance.

## 8. CONNECTION WIRE DIAGRAMS

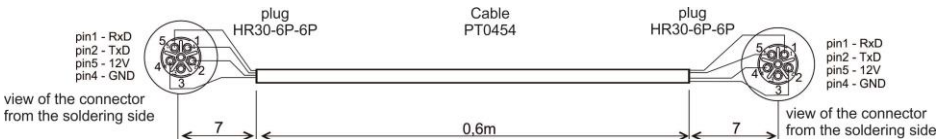

*IM02 cable – PUE CY10 terminal / 5Y-series balance*

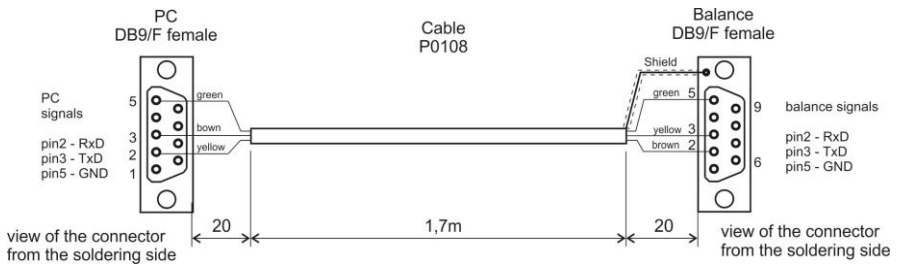

*IM02 cable – PC (RS232)*

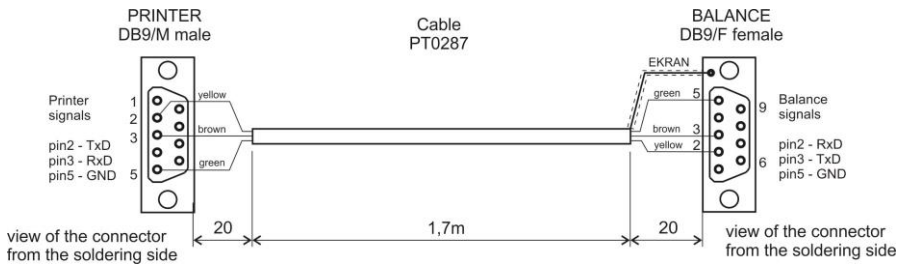

*IM02 cable – printer (RADWAG, ZEBRA)*

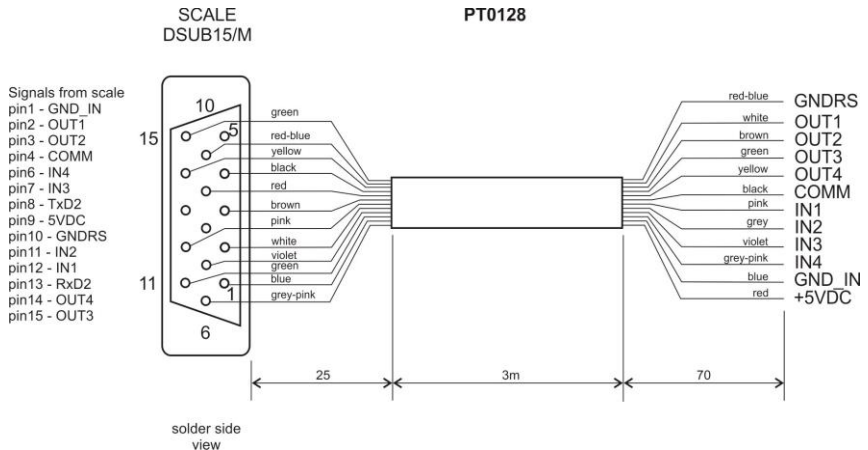

*IM02 cable – IN/OUT*

