



radwag.com

Scan the QR code to view additional scientific material that may be of interest to you.
There you will find more useful information in an accessible format!

User manual

ITKU-110-04-07-20-EN













HX7 Series Scales

1-load-cell multifunctional scales
4-load-cell platform scales
Pallet and beam scales
Track scales

JULY 2020

PRECAUTIONS

Prior to installation, use or maintenance activities, carefully read this user manual and follow the provided guidelines.

	Prior to the first use, carefully read this user manual. Use the weighing device only as intended.
	Place weighed loads in the centre of the weighing pan.
	Load the weighing pan with loads of gross weight which does not exceed the maximum capacity.
	Mind not to leave heavy loads on the weighing pan for longer periods of time.
	Protect the Terminal against considerable temperature variation, solar and UV radiation, substances causing chemical reactions.
	The HX7 Terminal must not be operated in hazardous areas endangered with explosion of gases, and in dusty environments.
	In case of damage, immediately unplug the device from the mains.
	Scales to be decommissioned must be decommissioned in accordance with valid legal regulations.
	Do not let battery discharge in case of prolonged storage of the device in low temperature.
	A worn out battery can be replaced only by the manufacturer or by the authorized service.
	Accumulators do not belong to regular household waste. The European legislation requires discharged accumulators to be collected and disposed separately from other communal waste with the aim of being recycled. Symbols on batteries identify harmful compounds: Pb = lead, Cd = cadmium, Hg = mercury. Dear user, you are obliged to dispose of the worn out batteries as regulated.
	If the scale is to be operated in conditions that are difficult due to electrostatics (e.g. printing house, packing centre, etc.), you must connect it to the earth wire. To enable this, the device features functional earthing terminal, marked with \perp symbol.

Contents

1. INTENDED USE	5
2. WARRANTY CONDITIONS	5
3. MAINTENANCE ACTIVITIES	6
3.1. Cleaning Stainless Steel Components	6
3.2. Cleaning ABS Components	6
3.3. Cleaning Platform Scales for Meat Industry	6
4. SERVICE AND REPAIR	8
5. RECYCLING	8
6. MECHANICAL DESIGN	9
6.1. 1-Load-Cell Scales	9
6.2. Multiple Load Cell Scales	9
6.3. Scales with Load-Cell Modules	10
6.4. Dimensions	11
6.5. Connectors	11
6.6. Pins Arrangement	12
6.7. Inputs / Outputs	13
6.7.1. Technical Specifications	13
6.7.2. I/O Schematic Diagrams	14
6.8. Operation Panel	14
7. SCALE INSTALLATION	15
7.1. Unpacking and Installation	15
7.1.1. 1-Load-Cell Multifunctional Scales	15
7.1.2. Platform Scales: HX7.4.xx.C, HX7.4.xx.H, HX7.4.xx.H/Z Series	16
7.1.3. Ramp Scales: HX7.4N Series	16
7.1.4. Track Scales: HX7.2K Series	17
7.2. Levelling: 1-Load-Cell Platform Scales	17
7.3. Levelling: 4-Load-Cell Platform Scales	17
7.4. Start-Up	18
7.5. Battery Status	18
8. HOME SCREEN	19
8.1. Top Bar	19
8.2. Weighing Result Window	20
8.3. Workspace	20
8.4. Pictograms	20
9. OPERATING THE MENU	20
9.1. Entering the Menu	20
9.2. Menu Keys	21
9.3. Entering Numbers / Text	22
9.3.1. Numerical Box	22
9.3.2. Text Box	23
9.3.3. Diacritical Sign Table	25
9.3.4. Special Sign Table	25
9.4. Return to Weighing	26
10. WEIGHING	26
10.1. Operation conditions for 1-load-cell-scales	26
10.2. Operation conditions for special scales	28
11. DIAGRAMS OF CONNECTION CABLES	28
12. TECHNICAL SPECIFICATION	30
13. ERROR MESSAGES	30

1. INTENDED USE

The scales are a response to growing market demands for a solution offering simplicity of operation and weighing process automated to the maximum. Due to use of a multifunctional PUE HX7.EX Terminal, the scales are a perfect solution for numerous industry applications. The PUE HX7 Terminal is equipped with a stainless steel housing of high IP. The PUE HX7 features 7" colour display guaranteeing perfect readability, and diode bar graph visualising MIN, MAX thresholds. It is operated using 22-key membrane keypad equipped with programmable function keys.

A scale of standard design offers RS232, USB type A, Ethernet, 4 I/O. Optionally it can be equipped with an internal battery, this allows its operation in places where there is no access to the mains. The device integrates with receipt and label printers, barcode scanners and PC accessories (mouse, keyboard, USB flash drive).

2. WARRANTY CONDITIONS

- A. RADWAG feels obliged to repair or exchange all elements that appear to be faulty by production or by construction.
- B. Defining defects of unclear origin and means of their elimination can only be realized with the assistance of the manufacturer and the user representatives.
- C. RADWAG does not bear any responsibility for damage or losses resulting from unauthorized or inadequate performing of production or service processes.
- D. The warranty does not cover:
 - mechanical damage caused by product exploitation other than intended, damage of thermal and chemical origin, damage caused by lightning, overvoltage in the power network or other random event,
 - inappropriate cleaning habits.
- E. Loss of warranty takes place if:
 - a repair is carried out outside an authorized service point,
 - service claims intrusion into mechanical or electronic construction by unauthorized people,
 - the scale does not bear security seal stickers.
- F. Warranty conditions outline the warranty period for rechargeable batteries attached to the device for 12 months.
- G. For detailed warranty conditions read the warranty certificate.
- H. Contact with the central authorized service: +48 (48) 386 63 30.

3. MAINTENANCE ACTIVITIES

In order to ensure safety in the course of cleaning, it is necessary to disconnect the device from the mains. With this condition met, uninstall the weighing pan and other detachable components.



Cleaning the weighing pan while still installed may cause damage of the measuring system.

3.1. Cleaning Stainless Steel Components

Avoid cleansers containing any corrosive chemicals, e.g. bleach (including chlorine). Do not use cleansers containing abrasive substances. Always remove the dirt using microfiber cloth to avoid damage of protective coating. In case of a daily maintenance:

1. Remove the dirt using cloth dipped in warm water.
2. For best results, add a little bit of dishwashing detergent.

3.2. Cleaning ABS Components

To clean dry surfaces and avoid smudging, use clean non-colouring cloths made of cellulose or cotton. You can use a solution of water and detergent (soap, dishwashing detergent, glass cleaner). Gently rub the cleaned surface and let it dry. Repeat the cleaning process if needed.

In the case of hard to remove contamination, e.g. residues of adhesive, rubber, resin, polyurethane foam etc., you can use a special cleaning agents based on a mixture of aliphatic hydrocarbons that do not dissolve plastics. Before using the cleanser for all surfaces we recommend carrying out tests. Do not use cleansers containing abrasive substances.

3.3. Cleaning Platform Scales for Meat Industry

Platforms of meat industry scales are made of stainless steel (0H18N9 by PN, 1.4301 by EN, 304 by AISI) and silicone components.

Exceptions are zink-plated track scales made of galvanized steel and powder-coated livestock scales with aluminium insert placed on the weighing pan.



Cleaning and disinfecting agents must be properly selected with regard to the scale.

In case of livestock scales, for commercial purposes it is necessary to use only stainless steel solutions.

These are much more resistant to long-lasting harsh conditions typical for slaughterhouses and livestock purchase sites. Powder-coated livestock scales can be used for rare small volume production, they must be stored clean in dry storage area and can be washed using water with a detergent. Do not use any agents or cleansers that are not intended to come into contact with skin (i.e. requiring use of protecting gloves).

In case of track scales it is forbidden to use chemicals containing penetrating substances. Grease and impurities accumulating in places where the scale track touches the line track must be cleaned off periodically.

Weighing Terminals of all scales feature stainless steel housings, polyester overlay and polyamide glands. Platforms of both livestock and ramp scales, their load-bearing structures and weighing tracks can be water-jet cleaned, the water temperature must be up to +80°C, respective cleanser needs to be added. When it comes to Terminals, it is forbidden to apply water-jet cleaning method, use of hot water is not allowed. It is recommended to cover the Terminals for the time of pressure washing of the surroundings.

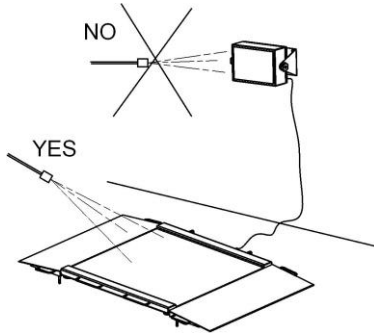

While cleaning platforms and Terminals of waterproof platform scales do not use either intense water jet or hot water, this is to avoid damage of silicone bellow of platform sensor cover and Terminal's operation panel or glands. Platforms of platform scales can be water-jet cleaned when uninstalled, they can also be cleaned by immersion into water.

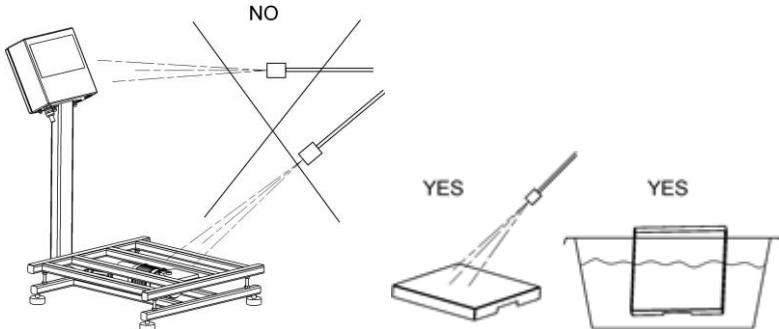

	Ramp scales		Livestock scales		Track scales		Waterproof platform scales		
	Platform with ramps	Weighing Terminal	Platform with cage	Weighing Terminal	Load-bearing structure with a load cell	Weighing Terminal	Platform	Weighing Terminal	Uninstalled pan
Water with detergents	Yes	Yes	Yes	Yes	Yes	Yes	Yes	Yes	Yes
Intense water jet	Yes	No	Yes	No	Yes	No	No	No	Yes
Hot water, 80°C max	Yes	No	Yes	No	Yes	No	No	No	Yes

4. SERVICE AND REPAIR

	<i>In case of any sign of damage, it is necessary to disconnect the device from the mains immediately. The damaged component must be replaced or repaired by RADWAG service directly.</i>
---	--

In case of any problems with correct operation of the scale, contact the closest manufacturer's service point.

In case of defects, deliver the faulty product to the manufacturer's service point. If the product cannot be delivered to the manufacturer's service point, call the service and report the defect. Repair scope and method will be set up.

	<i>The user is NOT ALLOWED to carry out any kind of repair of the device himself/herself. Any attempt of scale modification, repair etc., by unauthorized persons, will result with loss of validity of manufacturer-issued certificates, declarations and warranty.</i>
---	---

5. RECYCLING

HX7 scales must be recycled, they are not to be treated as a regular household waste. Scales to be decommissioned must be decommissioned in accordance with valid legal regulations.



6. MECHANICAL DESIGN

6.1. 1-Load-Cell Scales

1-load-cell HX7 scale is intended to carry out fast and precise mass measurement of up to 300 kg loads. Its characteristic feature is a platform with one load cell only. The platform is equipped with a stainless steel weighing pan. Depending on a scale model, the cross and base are made of either stainless steel or powder-coated steel.

1-load-cell scale design, the main components

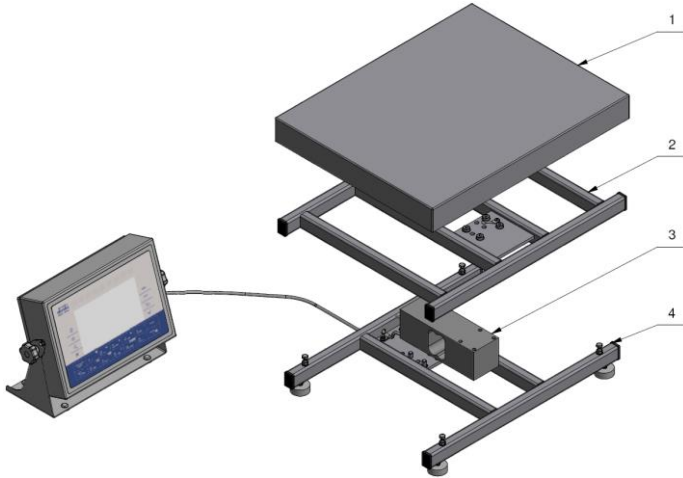

*1-load-cell scale design, the main components:
1 - weighing pan, 2 - cross, 3 - load cell, 4 - base.*

6.2. Multiple Load Cell Scales

Multiple load cell HX7 scale is intended to carry out fast and precise mass measurement of large loads. Its characteristic feature is a platform equipped with numerous load cells, usually four. The platform, depending on a scale model, is made of stainless steel or powder-coated steel, it features customized mechanical design suiting particular customer's requirements (pallet, beam, platform scales).

Multiple load cell scale design, the main components

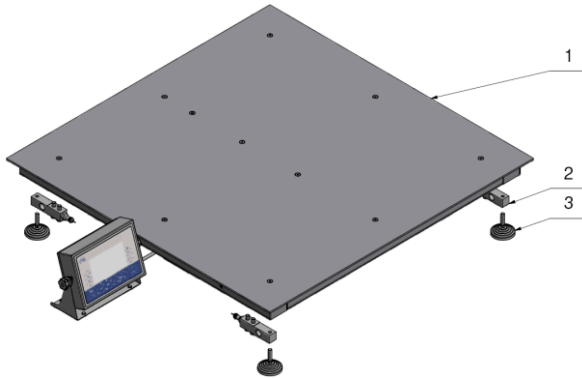

*Multiple load cell scale design, the main components:
1 - weighing pan, 2 - load cells, 3 - feet.*

6.3. Scales with Load-Cell Modules

HX7 scale with load cell modules is intended to carry out mass measurement of silos. Modules are built into construction of ground-fixed silo's support. In most cases, the scale design includes 3-4 load cell modules. The modules, depending on the model, are made of stainless or galvanized steel.

Scale design, the main components

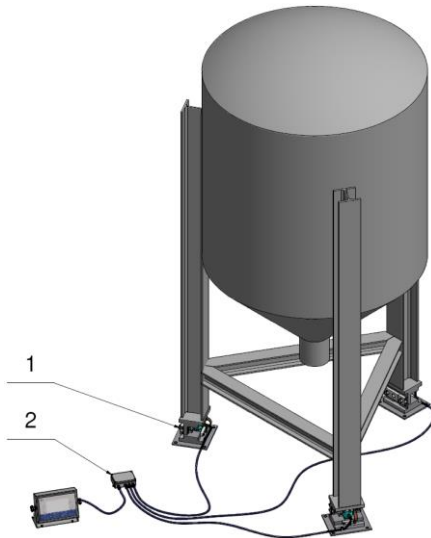

*Scale design, the main components:
1 - module, 2 - junction box.*

6.4. Dimensions

For overall dimensions read product card of a respective scale, the product cards are to be found on RADWAG website <http://www.radwag.com/>.



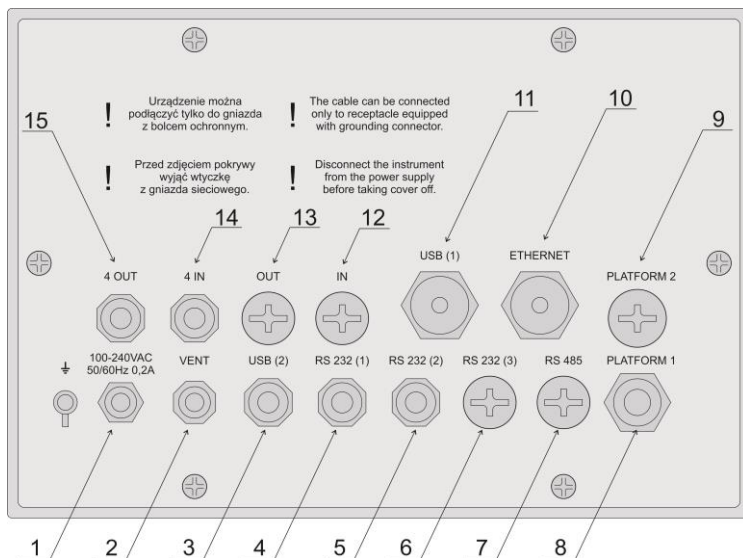



6.5. Connectors

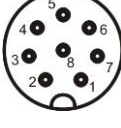

HX7 scale's connectors

1	Power cord's cable gland
2	Pressure compensating component
3	USB 2 M12 4P connector (option)
4	RS232 M12 8P connector
5	RS232 M12 8P connector (option)
6	RS232 M12 8P connector (option)
7	RS485 M12 8P connector (option)
8	Cable gland for a cable of a weighing platform 1
9	Cable gland for a cable of a weighing platform 2 (option)
10	ETHERNET RJ45 connector
11	USB connector
12	IN connector for additional interfaces (PROFIBUS)
13	OUT connector for additional interfaces (PROFIBUS, analog outputs)
14	Digital 4OUT M12 8P connector
15	Digital 4IN M12 8P connector

6.6. Pins Arrangement

<p>RS232 RS232 (2) RS232 (3)</p>		<p>Pin1 – NC Pin2 – RxD Pin3 – TxD Pin4 – NC Pin5 – GND Pin6 - +5VDC Pin7 – GNDZ Pin8 – 24VDC</p>
<p>RS485</p>		<p>Pin1 – B Pin2 – NC Pin3 – NC Pin4 – A Pin5 – GND Pin6 - GND Pin7 – 24VDC Pin8 – 24VDC</p>
<p>4INPUTS</p>		<p>Pin1 – OUT1 Pin2 – OUT2 Pin3 – WY3 Pin4 – OUT4 Pin5 – COM Pin6 – 24VDC Pin7 – GND Pin8 – NC</p>
<p>4OUTPUTS</p>		<p>Pin1 – IN1 Pin2 – IN2 Pin3 – IN3 Pin4 – IN4 Pin5 – COM Pin6 – 24VDC Pin7 – GND Pin8 – NC</p>
<p>PROFIBUS IN (female)</p>		<p>Pin1 – NC Pin2 – A Pin3 – NC Pin4 – B Pin5 – NC</p>
<p>PROFIBUS OUT (male)</p>		<p>Pin1 - +5V Pin2 – A Pin3 – GND Pin4 – B Pin5 – NC</p>
<p>USB 2</p>		<p>Pin1 – Vcc Pin2 – D- Pin3 – D+ Pin4 – GND</p>

6.7. Inputs / Outputs

Standard PUE HY10 Terminal is equipped with 4 optoisolated inputs and 4 semiconductor outputs (semiconductor relays). Signals are sent via M12 8P connectors.

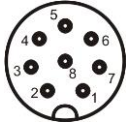
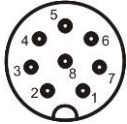
4OUTPUTS		Pin1 – OUT1 Pin2 – OUT2 Pin3 – WY3 Pin4 – OUT4 Pin5 – COM Pin6 – 24VDC Pin7 – GND Pin8 – NC
4INPUTS		Pin1 – IN1 Pin2 – IN2 Pin3 – IN3 Pin4 – IN4 Pin5 – COM Pin6 – 24VDC Pin7 – GND Pin8 – NC

The module has been designed to expand Terminal's functionality by additional 12 inputs and 12 outputs. It is equipped with optoisolated inputs and semiconductor outputs and enables free configuration of both the inputs and outputs (using Terminal menu). For 12IN/12OUT module, the Terminal's housing cover features two cable glands through which 3-meter long leads, terminated with strip wires, are fed.

6.7.1. Technical Specifications

Output parameters	
Output quantity	4
Output type	Solid-state relay
Cable cross-section	0.14 - 0.5mm ²
Maximum output current	0.5A DC
Maximum output voltage	30VDC, AC
Input parameters	
Input quantity	4
Input type	Optoisolated
Cable cross-section	0.14 – 0.5mm ²
Voltage range	5 - 24 VDC

6.7.2. I/O Schematic Diagrams

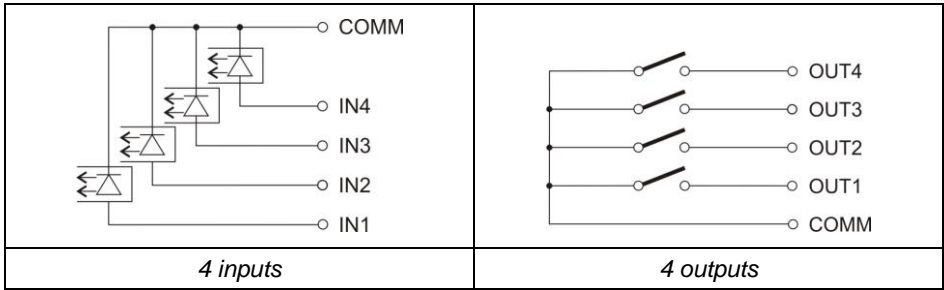



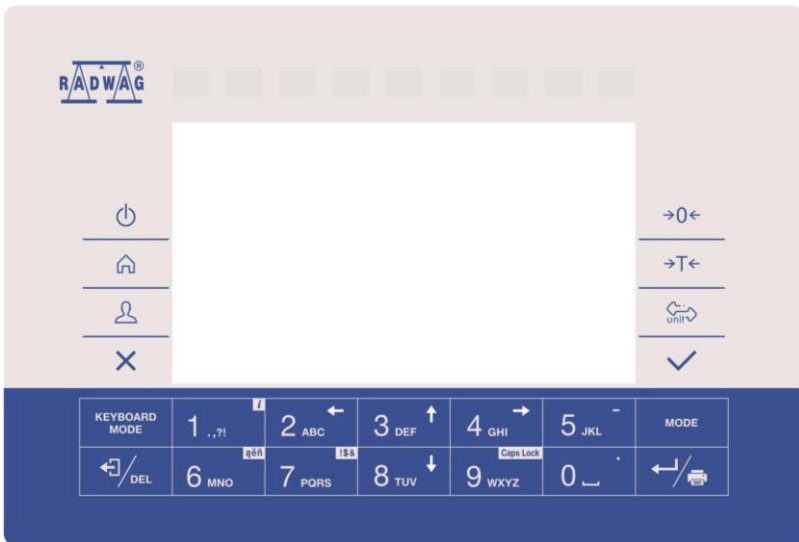









6.8. Operation Panel



Keys

	<p>Press to switch the device on / off.</p>
	<p>Press to enter the main menu.</p>
	<p>Press to log in.</p>
	<p>Press to cancel the message.</p>
	<p>Press to zero the scale.</p>

	Press to tare the scale.
	Press to change the weighing unit.
	Press to confirm the message.
	Press to confirm the weighing result (PRINT). Press to confirm the messages (ENTER).
	Press to cancel the messages.
	Press to change the working mode.
	Programmable key assigned to an on-screen button.  key – press it for a longer period of time to get scale info.
	Programmable key assigned to an on-screen button.
	Programmable key assigned to an on-screen button.
	Programmable key assigned to an on-screen button.
	Programmable key assigned to an on-screen button.

7. SCALE INSTALLATION

7.1. Unpacking and Installation

	<i>Mind not to damage cable connecting the Terminal and a weighing platform.</i>
--	---

7.1.1. 1-Load-Cell Multifunctional Scales

- Take the device out of the packaging.
- Place the device on a flat and even surface. Keep it far away from any sources of heat.
- Remove transport locks and install the weighing pan:

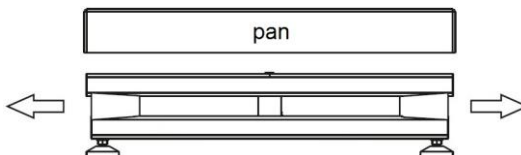

7.1.2. Platform Scales: HX7.4.xx.C, HX7.4.xx.H, HX7.4.xx.H/Z Series

- Take the device out of the packaging (pallet).
- Place the device on a flat and even surface. Keep it far away from any sources of heat.
- Remove transport locks (if installed):

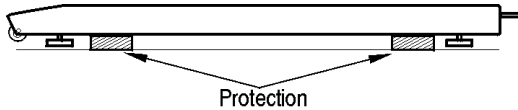

- Fix the feet (if not installed):

7.1.3. Ramp Scales: HX7.4N Series

- Take the device out of the packaging (pallet).
- Prior to installation, mount a steel bracket (2) onto a foot base (1), do it using an expanding ring (3), next screw the foot base (1) onto a foot pin (4).

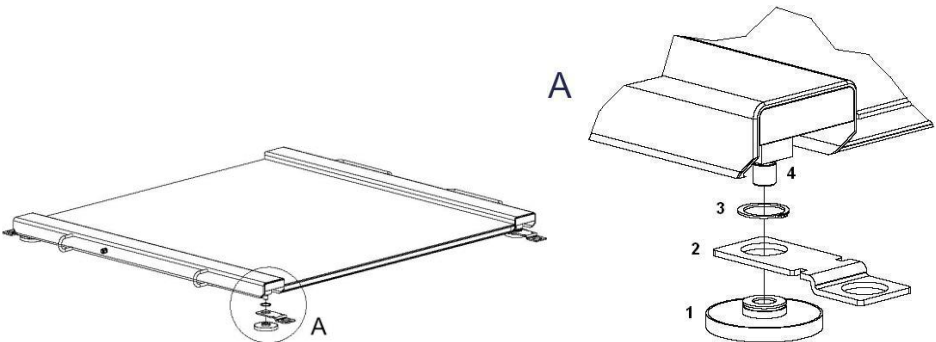

- Place the scale on an even surface, install ramps onto the steel brackets.
- Remove ramps, looking through bracket holes, mark spots where openings for anchor bolts are to be made.
- Drill openings, mount steel brackets to the ground.

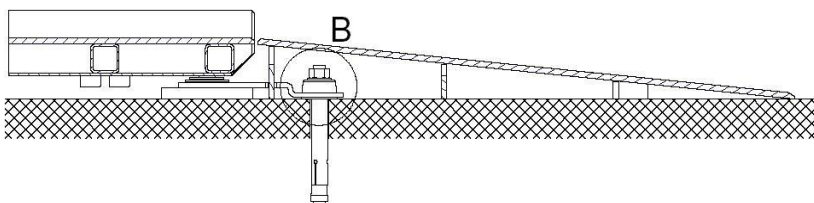

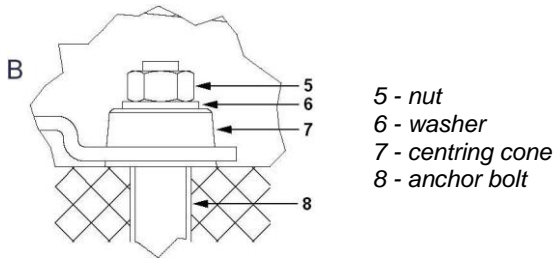

7.1.4. Track Scales: HX7.2K Series

Track scale is comprised of a load-bearing structure and load cells (measuring components). It is installed on a rail of the load-bearing structure of the suspended track, and the load cell is installed in a particular section of the track.



The scale must be installed by an authorized RADWAG service exclusively, otherwise the warranty gets null and void. During scale installation attention must be paid to stresses and the weighing system, i.e. the weighing system must lack the stresses.

7.2. Levelling: 1-Load-Cell Platform Scales

It is necessary to level the scale, do it by turning its feet. Keep turning the feet until the air bubble takes central position.



level - OK



level incorrect

7.3. Levelling: 4-Load-Cell Platform Scales

To level the scale use the levelling feet and the level Terminal. Each foot can be turned left and right, turning causes tilt.

Adjustment span of the scale level is narrow therefore the correct level is obtained using steel washers which are to be put under the feet.

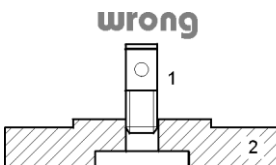

1 - leg mandrel
2 - basic of the leg



1 - leg mandrel
2 - basic of the leg

Keep turning the feet until the air bubble takes central position.









7.4. Start-Up

- Plug the power cord to the mains.
- Press  key, it is to be found at the top of the operation panel.
- Upon completed start-up the home screen is displayed automatically.

7.5. Battery Status

The scale optionally features an internal battery.  pictogram, displayed at the top of the screen, either signals battery status or informs that battery charging is in progress:

-  pictogram displayed in a cyclic manner: battery charging.
-  pictogram displayed continuously: battery charged within 75% - 100% range of permissible voltage,
-  pictogram displayed continuously: battery charged within 50% - 75% range of permissible voltage,
-  pictogram displayed continuously: battery charged within 25% - 50% range of permissible voltage,
-  pictogram displayed continuously: battery discharged (charge level below 25% of the permissible voltage), connect the scale to the mains in order to charge it,
- blinking  pictogram: damaged battery or battery lack,
- no  pictogram: scale not equipped with the battery.



Battery discharge is signalled by the following message:
<Excessively discharged battery. Scale shutdown is to occur>. Upon scale shutdown, connect it to the mains in order to charge the battery.

8. HOME SCREEN

The home screen features 4 sections: a top bar, a weighing result window, workspace, pictograms.

Home screen view:











Detailed instruction on how to configure the home screen is to be found in „PUE HX7 Terminal software manual“.

8.1. Top Bar



The top bar displays the following information:

	Working mode name and symbol.
	Device name.
	Wireless communication on.
	Communication with the USB flash drive on.
	PC keyboard connected.
	Printer connected.
	Battery charge status.
	Communication with a PC on.
	Communication with the E2R SYSTEM on.

8.2. Weighing Result Window

Weighing result window provides all weighing-related data.



8.3. Workspace

The workspace is to be found underneath the weighing result window.

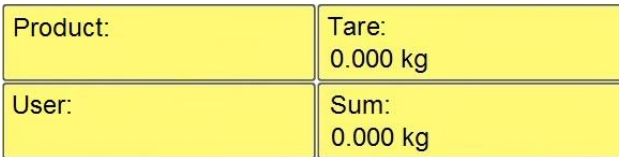

The workspace comprises 4 programmable widgets. Each working mode features a default home screen widget set. You can customize the screen.

8.4. Pictograms

The pictograms assigned to operation panel keys are to be found underneath the workspace.



You can define on-screen pictograms individually for each working mode.

9. OPERATING THE MENU

In order to navigate the program menu use the operation panel.











9.1. Entering the Menu

In order to enter the menu press  key. Background colour of the first menu entry differs from the remaining ones. To navigate the program menu use the keys that operate as arrow keys.

Menu view



9.2. Menu Keys

	Press to enter the main menu. Press to go to the home screen.
	Press to go back, or to discard entering parameter modifications.
	Press to go back. Press to delete a character when editing numeric and text values.
	Press to change keyboard mode when editing numeric and text values.
	Press to select/change working mode.
	Press to confirm/accept modifications.
	Press to go back, or to discard entering parameter modifications.
	Press to go up the menu, or to edit parameter value and change it by one digit up.
	Press to select parameter group that you want to operate. The first parameter of the selected parameters group is displayed.
	Press to go down the menu, or to edit parameter value and change it by one digit down.

9.3. Entering Numbers / Text

The software features two different edit boxes:



- numerical box (for entering part mass values, tare values, etc.)
- text box (for entering printout template, universal variable value, etc.).

Button functions change depending on the edit box type.

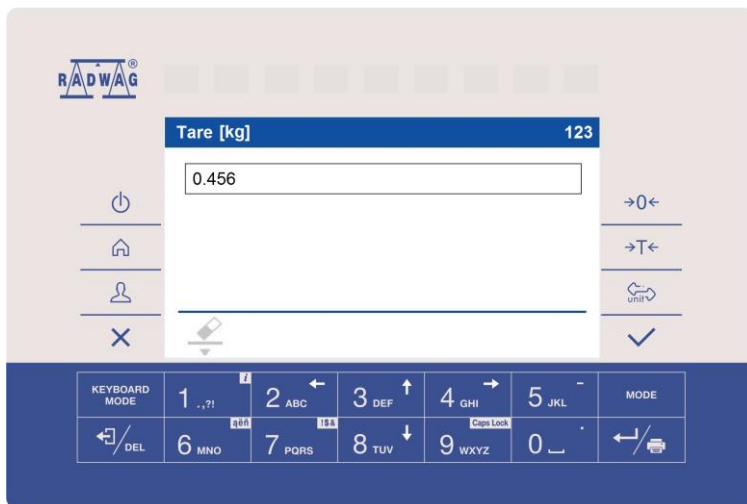

9.3.1. Numerical Box













Where:

123	Digit mode. To change keyboard working mode press KEYBOARD MODE key. Keyboard working mode options: 123 - digit mode,  - arrow keys operation, Fn - bottom bar operation.
	Press to clear box content.

Keys







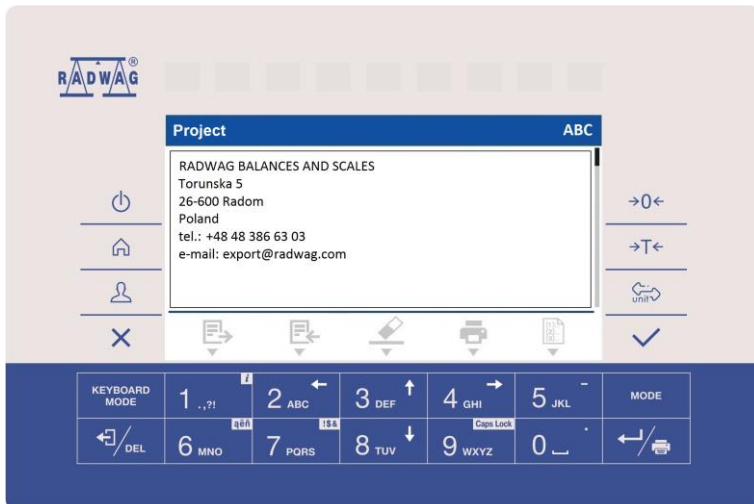





	Press to enter digit 1.
	Press to enter digit 2.
	Press to enter digit 3.

	Press to enter digit 4 .
	Press to enter digit 5 . Press to enter „-“ (minus), hold the key for a few seconds.
	Press to enter digit 6 .
	Press to enter digit 7 .
	Press to enter digit 8 .
	Press to enter digit 9 .
	Press to enter digit 0 . Press to enter „.” (dot), hold the key for a few seconds.
	Press to delete one character.
	Press to exit, the edit box content remains unmodified.
	Press to confirm the modifications.
	Press to change keyboard working mode.













9.3.2. Text Box





Where:

	<p>Upper-case character mode. To change keyboard working mode press  key. Keyboard working mode options:  - upper-case character mode,  - lower-case character mode,  - digit mode,  - arrow keys operation,  - bottom bar operation.</p>
	<p>Press to save the project to *.lb file on a USB flash drive.</p>
	<p>Press to read the project saved to *.lb file on a USB flash drive.</p>
	<p>Press to clear box content.</p>
	<p>Press to print the project using a printer connected to the scale.</p>
	<p>Press to view list of variables that can be used in the project.</p>



Keys

	<p>Press to enter . , { } : ° - .</p>
	<p>Press to enter a b c. Press to move the cursor to the left, long press.</p>
	<p>Press to enter d e f. Press to move the cursor up, long press.</p>
	<p>Press to enter g h i. Press to move the cursor to the right, long press.</p>
	<p>Press to enter j k l. Press to enter „ - ” sign, long press.</p>
	<p>Press to enter m n o. Press to activate „aëñ” function (diacritical sign table), long press.</p>
	<p>Press to enter p q r s. Press to activate „!\$&” function (special sign table), long press.</p>
	<p>Press to enter t u v. Press to move the cursor down, long press.</p>
	<p>Press to enter w x y z. Press to activate „Caps Lock” function, long press.</p>
	<p>Press to enter ␣ (space) sign. Press to enter „.” sign (dot), long press. ”.</p>
	<p>Press to go to the next line in the edit box.</p>
	<p>Press to delete one character.</p>



	Press to exit, the edit box content remains unmodified.
	Press to confirm the modifications.
	Press to change keyboard working mode.

9.3.3. Diacritical Sign Table

In order to activate diacritical sign table while editing the text box, press and hold  key. Diacritical signs characteristic for a particular interface language are automatically added to the table when the given language gets selected.

Diacritical sign table: Polish.	Diacritical sign table: English, German, French, Spanish.																																																																																								
<table border="1"> <tr><td>ą</td><td>ć</td><td>ę</td><td>ł</td><td>ń</td><td>ó</td><td>ś</td><td>ź</td><td>ż</td><td>á</td><td>č</td></tr> <tr><td>đ</td><td>é</td><td>ě</td><td>í</td><td>ň</td><td>ř</td><td>š</td><td>ú</td><td>ů</td><td>ý</td><td>ž</td></tr> <tr><td>â</td><td>ă</td><td>ä</td><td>î</td><td>ï</td><td>đ</td><td>ö</td><td>ø</td><td>ø</td><td>ř</td><td>ş</td></tr> <tr><td></td><td>!\$&</td><td>ű</td><td>ű</td><td>ť</td><td>ť</td><td>â</td><td>ø</td><td>æ</td><td></td><td></td></tr> </table>	ą	ć	ę	ł	ń	ó	ś	ź	ż	á	č	đ	é	ě	í	ň	ř	š	ú	ů	ý	ž	â	ă	ä	î	ï	đ	ö	ø	ø	ř	ş		!\$&	ű	ű	ť	ť	â	ø	æ			<table border="1"> <tr><td>ä</td><td>ö</td><td>ü</td><td>à</td><td>â</td><td>æ</td><td>œ</td><td>ç</td><td>è</td><td>é</td><td>ê</td></tr> <tr><td>ë</td><td>î</td><td>ï</td><td>ô</td><td>ù</td><td>û</td><td>ü</td><td>ÿ</td><td>ñ</td><td>á</td><td>ã</td></tr> <tr><td>â</td><td>ì</td><td>í</td><td>ö</td><td>ò</td><td>ó</td><td>õ</td><td>ú</td><td>ý</td><td>þ</td><td>š</td></tr> <tr><td></td><td>!\$&</td><td>ž</td><td>ğ</td><td>ş</td><td>ø</td><td>ı</td><td>ß</td><td></td><td></td><td></td></tr> </table>	ä	ö	ü	à	â	æ	œ	ç	è	é	ê	ë	î	ï	ô	ù	û	ü	ÿ	ñ	á	ã	â	ì	í	ö	ò	ó	õ	ú	ý	þ	š		!\$&	ž	ğ	ş	ø	ı	ß			
ą	ć	ę	ł	ń	ó	ś	ź	ż	á	č																																																																															
đ	é	ě	í	ň	ř	š	ú	ů	ý	ž																																																																															
â	ă	ä	î	ï	đ	ö	ø	ø	ř	ş																																																																															
	!\$&	ű	ű	ť	ť	â	ø	æ																																																																																	
ä	ö	ü	à	â	æ	œ	ç	è	é	ê																																																																															
ë	î	ï	ô	ù	û	ü	ÿ	ñ	á	ã																																																																															
â	ì	í	ö	ò	ó	õ	ú	ý	þ	š																																																																															
	!\$&	ž	ğ	ş	ø	ı	ß																																																																																		

Where:



	Press to activate „ Caps Lock ” function.
	Press to switch to special sign keyboard.

9.3.4. Special Sign Table

In order to activate special signs table while editing text box it is necessary to press and hold  key.



,	.	?	'	!	"	-	()	@	/
:	_	;	+	&	%	*	=	<	>	£
€	§	¥	°	[]	{	}	\	~	^
	aeñ	#	\$		µ	ß	©	®	™	`

Where:

	Function inactive.
	Press to switch to diacritical sign keyboard.

9.4. Return to Weighing

Introduced modifications are automatically recorded upon return to the home screen. To return to the home screen:

- press  key repeatedly, keep pressing the key until you see the home screen,
- press  key, the home screen is displayed immediately.

10. WEIGHING

Load the weighing pan. Read the result when  stability marker is displayed.

10.1. Operation conditions for 1-load-cell-scales

To assure long-term operation and correct mass measurements, follow the rules presented below:

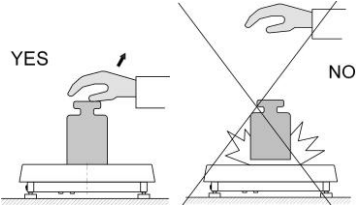
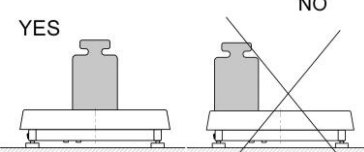
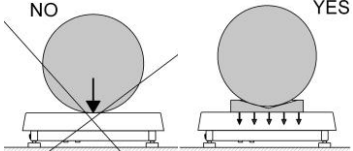
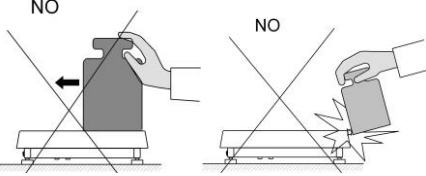
<p>Load the weighing pan steadily, avoid mechanical shocks.</p>	
<p>Place weighed loads centrally on the weighing pan (eccentricity errors are specified by EN 45501 standard, point 3.6.2.).</p>	
<p>Do not apply concentrated force (total load in one point).</p>	
<p>Avoid side loading, in particular side shocks.</p>	

10.2. Operation conditions for special scales

It is forbidden to apply load other than intended for a particular scale:

- beam scales; self-supporting, rigid load or load placed in rigid load-transferring packaging:

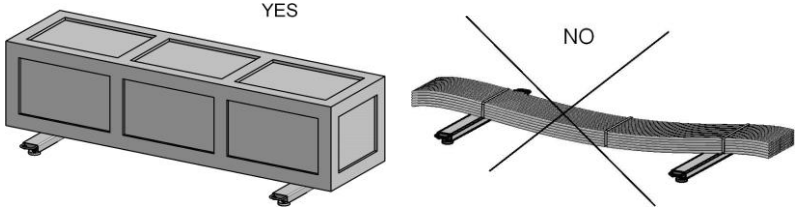

- pallet scales (load placed on EUR-pallet using pallet truck); middle block of pallet placed on the scale must remain unsupported:

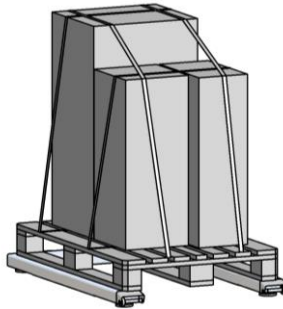

- ramp scales (trucks used in meat plants); it is necessary to select platform matching the span of truck casters, this is to make sure that in case of trucks of weight close to maximum capacity the load is transferred onto platform close to load-carrying sections (profiles):

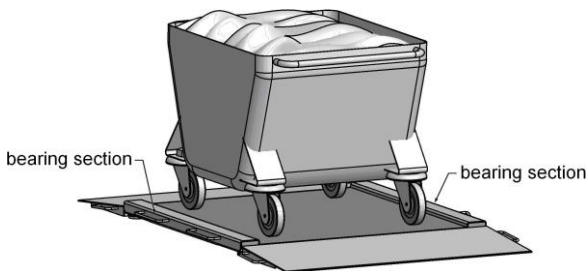

- track scales (product hanging on a hook) intended to slide:
 - hooks suiting a particular track and scale,
 - smooth slide down the track, no jerky moves, no swinging left or right,
 - evenly loaded track.

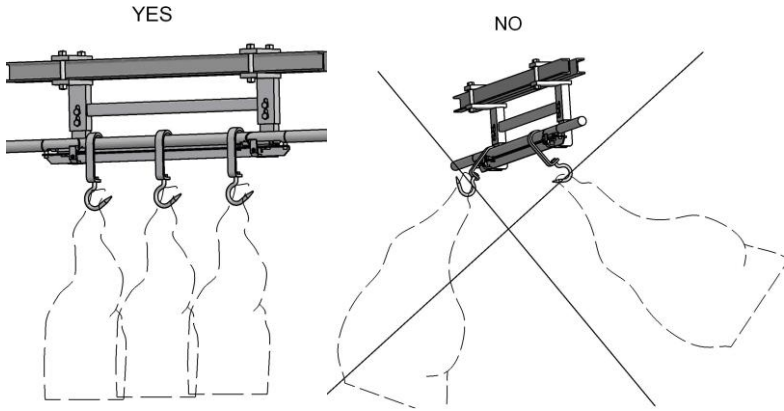

11. DIAGRAMS OF CONNECTION CABLES

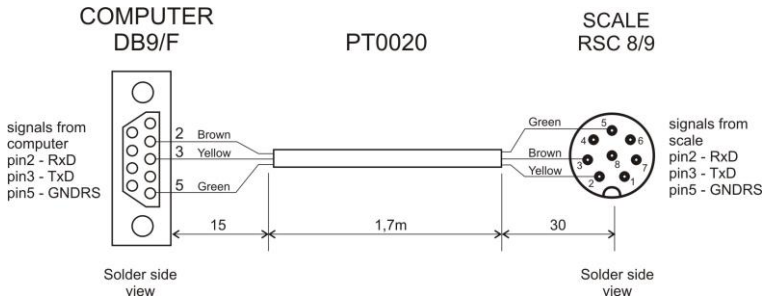

Terminal – computer cable

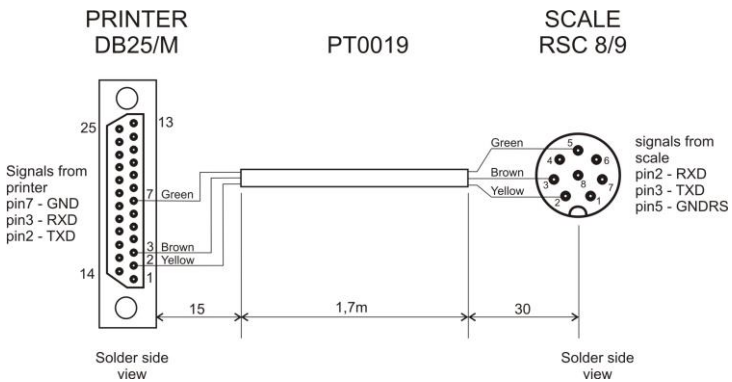

Terminal – printer cable (EPSON)

ZEBRA
DB9/M

PT0022

TERMINAL
RSC 8/9

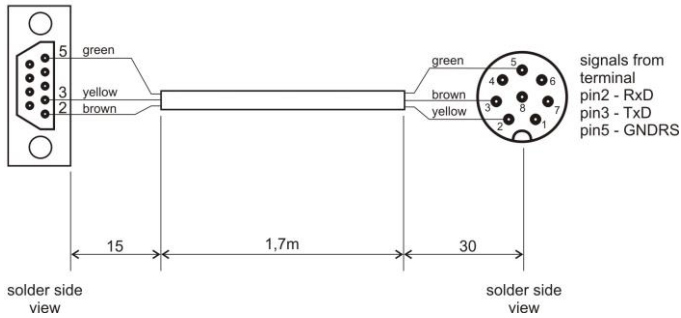

Terminal – printer cable (ZEBRA)

PT0256

TERMINAL
RSTS 8-184/2M

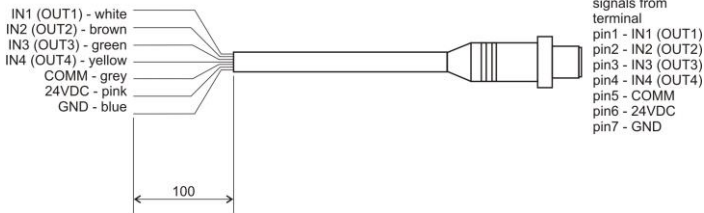

Terminal – IN/OUT cable

Symbol
LS2208

SCALE
RSC 8/9

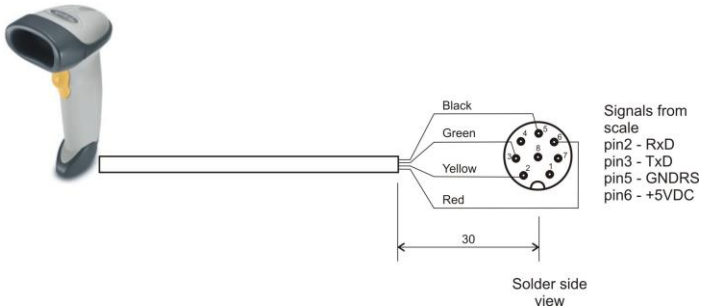

Terminal – barcode scanner cable (LS2208)

NOTE !!!
For STOP button use "NC" type contact.

PT0213

TERMINAL
RS8/9

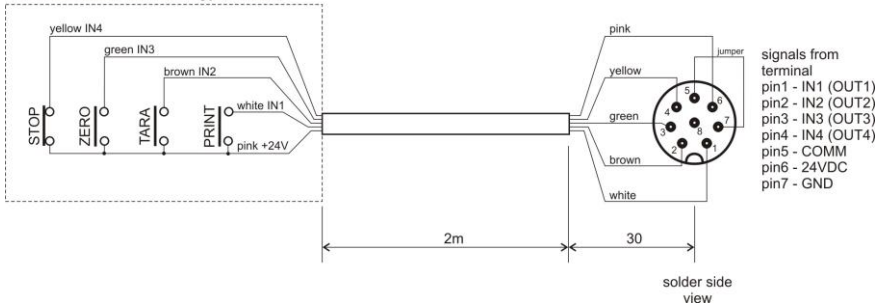

Terminal – PRINT, TARE, ZERO, STOP cable

„Scale-Ethernet” cable is a standard network cable terminated with RJ45 connectors on both ends.

12. TECHNICAL SPECIFICATION

For technical specifications of respective scales go to RADWAG website <http://www.radwag.com/>.

13. ERROR MESSAGES

- | | |
|---|---|
| <p>Start mass out of range.
Unload the weighing pan.</p> | <p>High limit of weighing range exceeded.
Unload the weighing pan.</p> |
| <p>Low limit of weighing range exceeded.
Install weighing pan.</p> | <p>Zeroing out of range.
Press tarring button or restart the scale.</p> |
| <p>Tarring out of range.
Press zeroing button or restart the scale.</p> | <p>Zeroing/tarring time out of range.
Weighing indication unstable.</p> |
| <p>Display capacity out of range
Unload the weighing pan</p> | |

