

Stainless Steel HX7.4N.H Ramp Scale

Measurements of large loads in moist environment
Easy and convenient platform loading

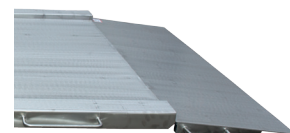

Ramps enable easy loading of the weighing platform



Bar graph is a graphic visualisation of current mass

HX7.4N.150.H2

Functions

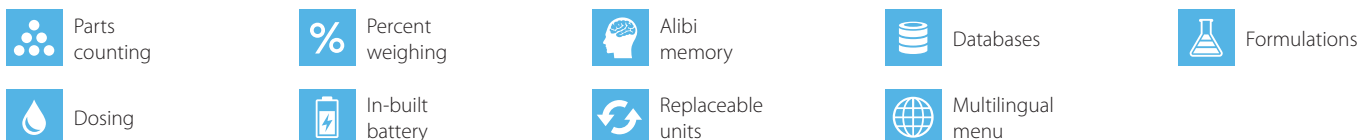

Features

Precise weighing results in industrial conditions

Mass measurement carried out using 4 load cells guarantees weighing accuracy regardless positioning of the load on the platform. The scale ensures precise and fast mass measurement in industrial conditions.

Reliability and Safety

Robust platform made of stainless steel allows to operate large loads, and the weighing pan made of tear plate prevents potential slips.

Versatility of use

HX7.4N.H scale can be applied in various industry areas, apart from standard weighing processes it allows to carry out parts counting, dosing, formulations.

Compatibility with PUE HX7 indicator

The scale can be operated via advanced PUE HX7 terminal with a hermetic stainless steel housing. The terminal features 7" colour graphic LCD and a membrane keyboard.

Communication Interfaces

The terminal is equipped with RS 322, RS 485, USB, Ethernet, digital inputs/ outputs and analog output. This enables cooperation with external devices: barcode scanners, printers, external displays, control buttons, light signalling towers, other controlling/signalling devices, systems for automatic process control and superior IT systems. It is possible due to the implemented complex character-based communication protocol.

Diodes

Diode bar graph takes top part of the operation panel, it consists of 9 red and green diode fields. Bar graph is a graphic visualisation informing on current net weight of a product in comparison with the scale range. The terminal features 3 working modes: 'linear', 'weighing thresholds signalling' and 'checkweighing'. The bar graph significantly increases the comfort of terminal operation during piecework in food industry when fast and unambiguous presentation of product mass deviation in comparison with the declared min and max values is crucial.

Uninterrupted Operation due to an Internal battery

Integrated battery of the weighing indicator enable several hours long mobile operation.

Ergonomics and Comfort of Operation

With use of a long cable it is possible to locate the indicator in a place facilitating convenient operation. An additional accessory enables placing it on a stand or mounting to the wall.

Customizable Instrument

Numerous variants of weighing pan dimensions and broad range of maximum capacities enable selecting the best weighing instrument suiting specific requirements and needs.

Technical Specifications

	HX7.4N.150.H1	HX7.4N.300.H1*	HX7.4N.600.H1*
Maximum capacity [Max]	150 kg	300 kg	600 kg
Minimum capacity	1 kg	2 kg	4 kg
Readability [d]	50 g	100 g	200 g
Max readability for non-verified scale	20 g	20 g	50 g
Verification unit [e]	50 g	100 g	200 g
Tare range	-150 kg	-300 kg	-600 kg
Verification	Yes	Yes	Yes
OIML class	III	III	III
Max number of platforms	2	2	2
Platform material	AISI304 stainless steel	AISI304 stainless steel	AISI304 stainless steel
Weighing pan material	AISI304 stainless steel	AISI304 stainless steel	AISI304 stainless steel
Indicator fastening	3 m cable	3 m cable	3 m cable
Display	7" graphic display	7" graphic display	7" graphic display
Keyboard	membrane, 22-key	membrane, 22-key	membrane, 22-key
Indicator type	PUE HX7	PUE HX7	PUE HX7
Ingress protection - platform	IP 68	IP 68	IP 68
Ingress protection - indicator	IP 66/68	IP 66/68	IP 66/68
RS232	1	1	1
USB	1	1	1
Ethernet	10 / 100 Mbit	10 / 100 Mbit	10 / 100 Mbit
IN / OUT	4 × IN, 4 × OUT	4 × IN, 4 × OUT	4 × IN, 4 × OUT
RS232 **	1	1	1
RS485 **	1	1	1
USB **	1	1	1
IN / OUT **	12 × IN, 12 × OUT	12 × IN, 12 × OUT	12 × IN, 12 × OUT
AN module **	1x 4-20mA, 20-1V	1x 4-20mA, 20-2V	1x 4-20mA, 50-4V
Communication protocol	ASCII Text / Modbus RTU / TCP	ASCII Text / Modbus RTU / TCP	ASCII Text / Modbus RTU / TCP
Power supply	100 ÷ 240 V AC 50 ÷ 60 Hz	100 ÷ 240 V AC 50 ÷ 60 Hz	100 ÷ 240 V AC 50 ÷ 60 Hz
Optional power supply **	12-24 V DC	12-24 V DC	12-24 V DC
Max Power consumption	25 W	25 W	25 W
Operating temperature	-10 ÷ +40 °C	-10 ÷ +40 °C	-10 ÷ +40 °C
Relative humidity ***	10 ÷ 85%	10 ÷ 85%	10 ÷ 85%
Transport and storage temperature	-10 ÷ +50 °C	-10 ÷ +50 °C	-10 ÷ +50 °C
Weighing pan dimensions	840 × 860 mm	840 × 860 mm	840 × 860 mm
Net weight ****	104.7 kg	104.7 kg	104.7 kg
Gross weight ****	140.5 kg	140.5 kg	140.5 kg
Packaging dimensions	125 × 95 × 72 cm	125 × 95 × 72 cm	125 × 95 × 72 cm

* possibility to make the device a dual range weighing model

** optional design

*** non-condensing conditions

**** mass of the packaging containing the PUE HX7 indicator and the platform

Technical Specifications

	HX7.4N.150.H2*	HX7.4N.300.H2*	HX7.4N.600.H2*
Maximum capacity [Max]	150 kg	300 kg	600 kg
Minimum capacity	1 kg	2 kg	4 kg
Readability [d]	50 g	100 g	200 g
Max readability for non-verified scale	20 g	20 g	50 g
Verification unit [e]	50 g	100 g	200 g
Tare range	-150 kg	-300 kg	-600 kg
Verification	Yes	Yes	Yes
OIML class	III	III	III
Max number of platforms	2	2	2
Platform material	AISI304 stainless steel	AISI304 stainless steel	AISI304 stainless steel
Weighing pan material	AISI304 stainless steel	AISI304 stainless steel	AISI304 stainless steel
Indicator fastening	3 m cable	3 m cable	3 m cable
Display	7" graphic display	7" graphic display	7" graphic display
Keyboard	membrane, 22-key	membrane, 22-key	membrane, 22-key
Indicator type	PUE HX7	PUE HX7	PUE HX7
Ingress protection - platform	IP 68	IP 68	IP 68
Ingress protection - indicator	IP 66/68	IP 66/68	IP 66/68
RS232	1	1	1
USB	1	1	1
Ethernet	10 / 100 Mbit	10 / 100 Mbit	10 / 100 Mbit
IN / OUT	4 × IN, 4 × OUT	4 × IN, 4 × OUT	4 × IN, 4 × OUT
RS232 **	1	1	1
RS485 **	1	1	1
USB **	1	1	1
IN / OUT **	12 × IN, 12 × OUT	12 × IN, 12 × OUT	12 × IN, 12 × OUT
AN module **	1x 4-20mA, 20-1V	1x 4-20mA, 20-2V	1x 4-20mA, 50-4V
Communication protocol	ASCII Text / Modbus RTU / TCP	ASCII Text / Modbus RTU / TCP	ASCII Text / Modbus RTU / TCP
Power supply	100 ÷ 240 V AC 50 ÷ 60 Hz	100 ÷ 240 V AC 50 ÷ 60 Hz	100 ÷ 240 V AC 50 ÷ 60 Hz
Optional power supply **	12-24 V DC	12-24 V DC	12-24 V DC
Max Power consumption	25 W	25 W	25 W
Operating temperature	-10 ÷ +40 °C	-10 ÷ +40 °C	-10 ÷ +40 °C
Relative humidity ***	10 ÷ 85%	10 ÷ 85%	10 ÷ 85%
Transport and storage temperature	-10 ÷ +50 °C	-10 ÷ +50 °C	-10 ÷ +50 °C
Weighing pan dimensions	1100 × 1200 mm	1100 × 1200 mm	1100 × 1200 mm
Net weight ****	149.7 kg	149.7 kg	149.7 kg
Gross weight ****	190.5 kg	190.5 kg	190.5 kg
Packaging dimensions	150 × 130 × 72 cm	150 × 130 × 72 cm	150 × 130 × 72 cm

* possibility to make the device a dual range weighing model

** optional design

*** non-condensing conditions

**** mass of the packaging containing the PUE HX7 indicator and the platform

Technical Specifications

	HX7.4N.1500.H2*	HX7.4N.300.H3*	HX7.4N.600.H3*
Maximum capacity [Max]	1500 kg	300 kg	600 kg
Minimum capacity	10 kg	2 kg	4 kg
Readability [d]	500 g	100 g	200 g
Max readability for non-verified scale	100 g	50 g	50 g
Verification unit [e]	500 g	100 g	200 g
Tare range	-1500 kg	-300 kg	-600 kg
Verification	Yes	Yes	Yes
OIML class	III	III	III
Max number of platforms	2	2	2
Platform material	AISI304 stainless steel	AISI304 stainless steel	AISI304 stainless steel
Weighing pan material	AISI304 stainless steel	AISI304 stainless steel	AISI304 stainless steel
Indicator fastening	3 m cable	3 m cable	3 m cable
Display	7" graphic display	7" graphic display	7" graphic display
Keyboard	membrane, 22-key	membrane, 22-key	membrane, 22-key
Indicator type	PUE HX7	PUE HX7	PUE HX7
Ingress protection - platform	IP 68	IP 68	IP 68
Ingress protection - indicator	IP 66/68	IP 66/68	IP 66/68
RS232	1	1	1
USB	1	1	1
Ethernet	10 / 100 Mbit	10 / 100 Mbit	10 / 100 Mbit
IN / OUT	4 × IN, 4 × OUT	4 × IN, 4 × OUT	4 × IN, 4 × OUT
RS232 **	1	1	1
RS485 **	1	1	1
USB **	1	1	1
IN / OUT **	12 × IN, 12 × OUT	12 × IN, 12 × OUT	12 × IN, 12 × OUT
AN module **	1x 4-20mA, 100-10V	1x 4-20mA, 50-2V	1x 4-20mA, 50-4V
Communication protocol	ASCII Text / Modbus RTU / TCP	ASCII Text / Modbus RTU / TCP	ASCII Text / Modbus RTU / TCP
Power supply	100 ÷ 240 V AC 50 ÷ 60 Hz	100 ÷ 240 V AC 50 ÷ 60 Hz	100 ÷ 240 V AC 50 ÷ 60 Hz
Optional power supply **	12-24 V DC	12-24 V DC	12-24 V DC
Max Power consumption	25 W	25 W	25 W
Operating temperature	-10 ÷ +40 °C	-10 ÷ +40 °C	-10 ÷ +40 °C
Relative humidity ***	10 ÷ 85%	10 ÷ 85%	10 ÷ 85%
Transport and storage temperature	-10 ÷ +50 °C	-10 ÷ +50 °C	-10 ÷ +50 °C
Weighing pan dimensions	1100 × 1200 mm	1200 × 1500 mm	1200 × 1500 mm
Net weight ****	189.7 kg	179.7 kg	179.7 kg
Gross weight ****	230.5 kg	225.5 kg	275.5 kg
Packaging dimensions	150 × 130 × 72 cm	160 × 160 × 72 cm	160 × 160 × 72 cm

* possibility to make the device a dual range weighing model

** optional design

*** non-condensing conditions

**** mass of the packaging containing the PUE HX7 indicator and the platform

Technical Specifications

	HX7.4N.1500.H3*	HX7.4N.300.H4*	HX7.4N.600.H4*
Maximum capacity [Max]	1500 kg	300 kg	600 kg
Minimum capacity	10 kg	2 kg	4 kg
Readability [d]	500 g	100 g	200 g
Max readability for non-verified scale	100 g	50 g	50 g
Verification unit [e]	500 g	100 g	200 g
Tare range	-1500 kg	-300 kg	-600 kg
Verification	Yes	Yes	Yes
OIML class	III	III	III
Max number of platforms	2	2	2
Platform material	AISI304 stainless steel	AISI304 stainless steel	AISI304 stainless steel
Weighing pan material	AISI304 stainless steel	AISI304 stainless steel	AISI304 stainless steel
Indicator fastening	3 m cable	3 m cable	3 m cable
Display	7" graphic display	7" graphic display	7" graphic display
Keyboard	membrane, 22-key	membrane, 22-key	membrane, 22-key
Indicator type	PUE HX7	PUE HX7	PUE HX7
Ingress protection - platform	IP 68	IP 68	IP 68
Ingress protection - indicator	IP 66/68	IP 66/68	IP 66/68
RS232	1	1	1
USB	1	1	1
Ethernet	10 / 100 Mbit	10 / 100 Mbit	10 / 100 Mbit
IN / OUT	4 × IN, 4 × OUT	4 × IN, 4 × OUT	4 × IN, 4 × OUT
RS232 **	1	1	1
RS485 **	1	1	1
USB **	1	1	1
IN / OUT **	12 × IN, 12 × OUT	12 × IN, 12 × OUT	12 × IN, 12 × OUT
AN module **	1x 4-20mA, 100-10V	1x 4-20mA, 50-2V	1x 4-20mA, 50-4V
Communication protocol	ASCII Text / Modbus RTU / TCP	ASCII Text / Modbus RTU / TCP	ASCII Text / Modbus RTU / TCP
Power supply	100 ÷ 240 V AC 50 ÷ 60 Hz	100 ÷ 240 V AC 50 ÷ 60 Hz	100 ÷ 240 V AC 50 ÷ 60 Hz
Optional power supply **	12-24 V DC	12-24 V DC	12-24 V DC
Max Power consumption	25 W	25 W	25 W
Operating temperature	-10 ÷ +40 °C	-10 ÷ +40 °C	-10 ÷ +40 °C
Relative humidity ***	10 ÷ 85%	10 ÷ 85%	10 ÷ 85%
Transport and storage temperature	-10 ÷ +50 °C	-10 ÷ +50 °C	-10 ÷ +50 °C
Weighing pan dimensions	1200 × 1500 mm	1500 × 1500 mm	1500 × 1500 mm
Net weight ****	229.7 kg	269.7 kg	269.7 kg
Gross weight ****	275.5 kg	315.5 kg	315.5 kg
Packaging dimensions	160 × 160 × 72 cm	190 × 160 × 72 cm	190 × 160 × 72 cm

* possibility to make the device a dual range weighing model

** optional design

*** non-condensing conditions

**** mass of the packaging containing the PUE HX7 indicator and the platform

Technical Specifications

	HX7.4N.1500.H4*
Maximum capacity [Max]	1500 kg
Minimum capacity	10 kg
Readability [d]	500 g
Max readability for non-verified scale	100 g
Verification unit [e]	500 g
Tare range	-1500 kg
Verification	Yes
OIML class	III
Max number of platforms	2
Platform material	AISI304 stainless steel
Weighing pan material	AISI304 stainless steel
Indicator fastening	3 m cable
Display	7" graphic display
Keyboard	membrane, 22-key
Indicator type	PUE HX7
Ingress protection - platform	IP 68
Ingress protection - indicator	IP 66/68
RS232	1
USB	1
Ethernet	10 / 100 Mbit
IN / OUT	4 × IN, 4 × OUT
RS232 **	1
RS485 **	1
USB **	1
IN / OUT **	12 × IN, 12 × OUT
AN module **	1x 4-20mA, 100-10V
Communication protocol	ASCII Text / Modbus RTU / TCP
Power supply	100 ÷ 240 V AC 50 ÷ 60 Hz
Optional power supply **	12-24 V DC
Max Power consumption	25 W
Operating temperature	-10 ÷ +40 °C
Relative humidity ***	10 ÷ 85%
Transport and storage temperature	-10 ÷ +50 °C
Weighing pan dimensions	1500 × 1500 mm
Net weight ****	269.7 kg
Gross weight ****	315.5 kg
Packaging dimensions	190 × 160 × 72 cm

* possibility to make the device a dual range weighing model

** optional design

*** non-condensing conditions

**** mass of the packaging containing the PUE HX7 indicator and the platform

Dimensions

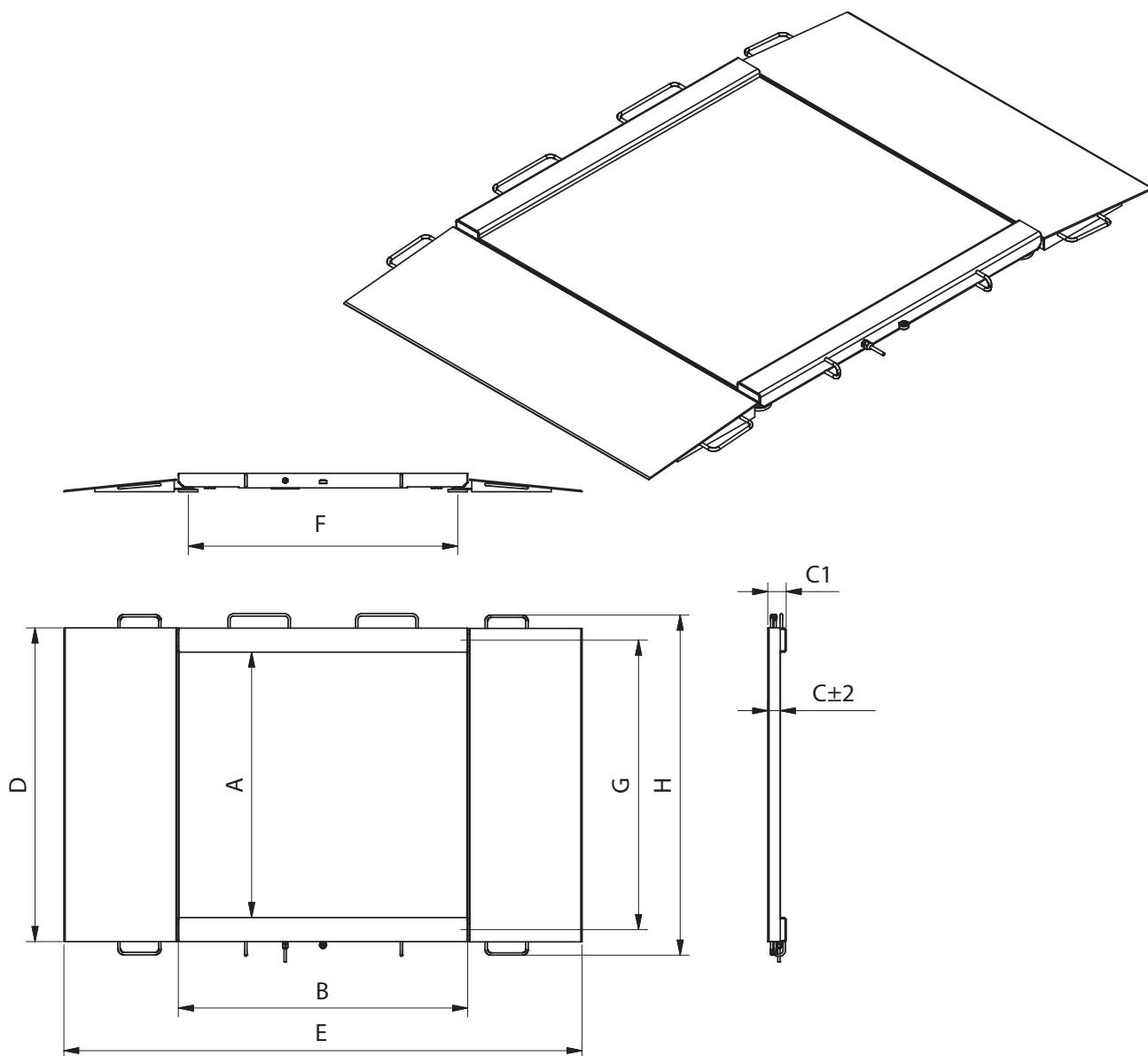

Model	Max	A	B	C	C1	D	E	F	G	H
HX7.4N.150.H1	150 kg	840	860	45,5	76	1040	1710	778	940	1170
HX7.4N.300.H1	300 kg	840	860	45,5	76	1040	1710	778	940	1170
HX7.4N.600.H1	600 kg	840	860	45,5	76	1040	1710	778	940	1170
HX7.4N.150.H2	1500 kg	1100	1200	45,5	76	1300	2050	1118	1200	1430
HX7.4N.300.H2	300 kg	1100	1200	45,5	76	1300	2050	1118	1200	1430
HX7.4N.600.H2	600 kg	1100	1200	45,5	76	1300	2050	1118	1200	1430
HX7.4N.1500.H2	1500 kg	1100	1200	52,5	76	1300	2150	1118	1200	1430
HX7.4N.300.H3	300 kg	1200	1500	45,5	76	1400	2350	1418	1300	1530
HX7.4N.600.H3	600 kg	1200	1500	45,5	76	1400	2350	1418	1300	1530
HX7.4N.1500.H3	1500 kg	1200	1500	52,5	76	1400	2450	1418	1300	1530
HX7.4N.300.H4	300 kg	1500	1500	52,5	76	1700	2450	1418	1600	1830
HX7.4N.600.H4	600 kg	1500	1500	52,5	76	1700	2450	1418	1600	1830
HX7.4N.1500.H4	1500 kg	1500	1500	52,5	76	1700	2450	1418	1600	1830

* dimensions in mm

Accessories

Peripheral Devices

- Epson dot matrix printer
- Zebra labellers
- WWG-2/4 large-size display
- LCD – WD-4/3 display (backlit)
- stack light
- control buttons
- transponder card scanner
- barcode scanner

Cables, Converters

- PT0019 2m cable (5, 10m optionally) – for Citizen and Epson printers
- PT0022 2m cable (5, 10m optionally) – for ZEBRA printers (later models)
- PT0232 2m cable (5, 10m optionally) – for ZEBRA (older models), INTERMEC and ELTRON printers
- PT0020 2m cable (5, 10m optionally) – for computer
- PT0087 cable (M12 4P) 1.7m – for USB printer
- PT0238 1.7m cable – for printer (A-B)
- PT0084 (M12 4P) 1.7m cable – for USB adapter
- PT0383 2m cable (5, 10m optionally) – for RS485
- PT0256 2m cable (5, 10m optionally) – for IN/OUT

Dedicated Software

R-LAB

- collecting measurements
- carrying out statistical analysis of measurements
- customized graphs and reports

Label Editor R02

- designing label templates
- sending graphics and fonts to label printers
- printing label templates using connected printers

E2R Weighing Records

- complete, automated databases synchronization
- fully supported processes of labelling and parts counting
- record of weighings, weighings archiving
- basic and advanced (with graphs) reports

RAD KEY

- Establishing cooperation between a weighing instrument and a computer

LabView Driver

- operation of RADWAG balances in LabView environment

R.Barcode

- The basic function software is presentation of the data sent by barcode scanners connected to PC via USB or RS232

Radwag Development Studio

- presentation of functions (and subfunctions) of communication protocol (Common Communication Protocol)
- possibility of connection with weighing equipment on which each function is carried out,
- library with mass control, contained within the development environment
- complete documentation of the communication protocol
- set of user manuals for different solutions addressed for programmers employed in companies using RADWAG-manufactured weighing equipment

RADWAG Connect

- establishing communication with all balances, scales and weighing modules using Common Communication Protocol
- communication via local network,
- support of basic functions
- auto searching for devices
- connecting with few devices simultaneously, swapping between them
- clear list of connected platforms
- record of measurements in the program,
- export of carried out measurements to CSV file,
- work performed using freely selected device with Windows 10