



PS 1000.R2.H Precision Balance

More information on the website
radwag.com/en/info,w1,X0B



PS 1000.R2.H Precision Balance

The drawings, photos and graphics used are for illustrative purposes only.

Functions



Autotest



Dosing



Percent Weighing



Totalizing



Parts counting



Peak hold



Newton unit
measurement



Statistics



Checkweighing



GLP Procedures



Animal weighing



Density determination

Datasheet

PS 1000.R2.H Precision Balance	
Metrological parameters	
Maximum capacity [Max]	1000 g
Minimum load	20 mg
Readability [d]	0,001 g
Tare range	-1000 g
Repeatability (Max)	0,0015 g
Repeatability (5% Max)	0,0005 g
Linearity	±0,003 g
Stabilization time	2 s
Adjustment	internal (automatic)
Physical parameters	
Leveling system	manualny
Display	LCD (backlit)
Weighing pan dimensions	ø100 mm
Packaging dimensions	475×380×345 mm
Net weight	4,5 kg
Gross weight	6 kg
Construction	
Protection class	IP 54
Communication interface	
Communication interface	2×RS232 ¹ , USB-A, USB-B, Wi-Fi (option)
Electrical parameters	
Power supply	Adapter: 100 – 240V AC 50/60Hz 0,6A; 12V DC 1,2A Balance: 12 – 15V DC 0,4A max
Power consumption	4 W
Environmental conditions	
Operating temperature	+10 ÷ +40 °C
Relative humidity	40% ÷ 80%

Repeatability is expressed as a standard deviation from 10 weighing cycles. Stabilization time depends on the ambient conditions and the dynamics of weighing pan loading; specified for FAST profile. 1 Barcode scanners, available as weighing instrument accessory, communicate with the instrument via RS232 interface exclusively.

* Wi-Fi® is a registered trademark of Wi-Fi® Alliance.



Accessories

Antivibration Tables
Power Adapters
Cigarette lighter receptacle power supply cables
USB cable (scale - printer)
Barcode scanners
RS 232, RS 485 cables

Displays
Receipt Printer
RS 232, RS 485 cables
Protective cover for balances
Under-pan weighing
RS 232 cables (scale - printer)

Software

RAD-KEY

R Panel

Device dimensions

PS 1000.R2.H Precision Balance

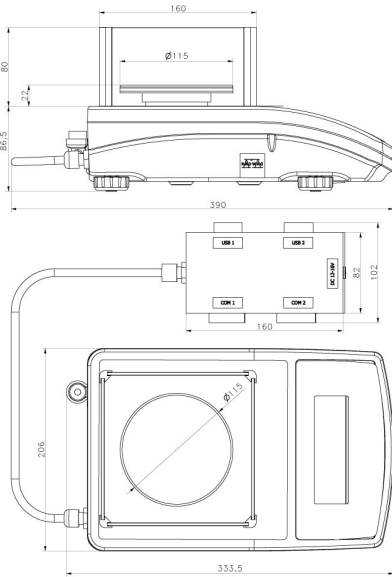

PS R2.H, d = 1 mg

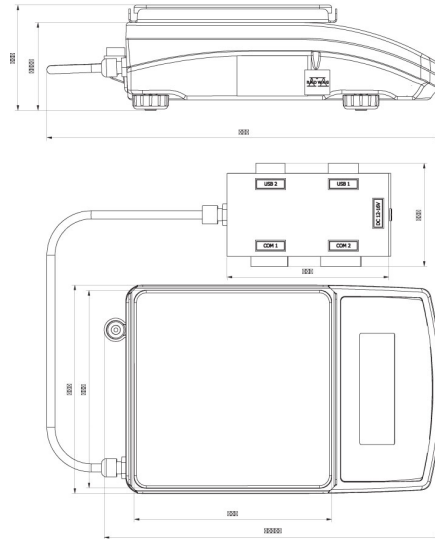

PS R2.M.H, d = 10 mg