

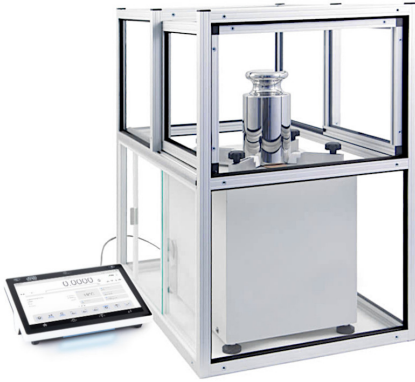

More information on the website
radwag.com/en/info,w1,MLL

APP 10.5Y.KO Mass Comparator



APP 10.5Y.KO Mass Comparator

The drawings, photos and graphics used are for illustrative purposes only.

Datasheet

	APP 10.5Y.KO Mass Comparator
Metrological parameters	
E1 Calibration Range	5 kg ÷ 10 kg
E2 Calibration Range	1 kg ÷ 10 kg
F1 Calibration Range	500 g ÷ 10 kg
F2 Calibration Range	100 g ÷ 10 kg
M1 Calibration Range	100 g ÷ 10 kg
M2 Calibration Range	100 g ÷ 10 kg
Maximum capacity [Max]	10,2 kg
Readability [d]	0,1 mg
Standard repeatability [5% Max]	0,35 mg
Standard repeatability [Max]	0,4 mg
Permissible repeatability	0,7 mg
Eccentricity (tested load)	2d / 1 mm
Electric compensation range	-100 g ÷ +200 g
Stabilization time	30 s
Adjustment	external
Physical parameters	
Display	10" graphic colour touchscreen
Weighing pan dimensions	ø190 (ø300) mm
Weighing device dimensions	455×300×380 mm
Controlling device dimensions	249×170×72 mm
Packaging dimensions	1160×650×700 mm
Chamber packaging size	960×920×735 mm
Net weight	46 kg
Gross weight	60 kg
Communication interface	
Communication interface	2×USB-A, USB-C, HDMI, Ethernet, Wi-Fi, Hotspot
Environmental conditions	
Operating temperature	+15 ÷ +30 °C
Operating temperature change rate	±0,5°C/12h (±0,3°C/1h)
Relative humidity	40% ÷ 60%
Relative humidity change rate	±5%/4h

Repeatability is expressed as a standard deviation determined for 6 ABBA cycles. Standard deviation is experimentally determined under ambient conditions for calibration of F2 class mass standards specified in OIML R111 (Table C.1.) document.

* Wi-Fi® is a registered trademark of Wi-Fi® Alliance.



Accessories

Self-centering pan for APP KO comparator
RFID Tags
Antivibration Tables
Additional modules
Protective cover for balances
Barcode scanners
RS 232, RS 485 cables

Label Printers
THBR 2.0 System - Ambient Conditions Monitoring
Receipt Printer
Fingerprint Reader
RS 232, RS 485 cables
Anti-Draft Chamber for Mass Comparators
RS 232 cables (scale - printer)

Software

RAD-KEY
RMCS System

RMCS Lite

Device dimensions

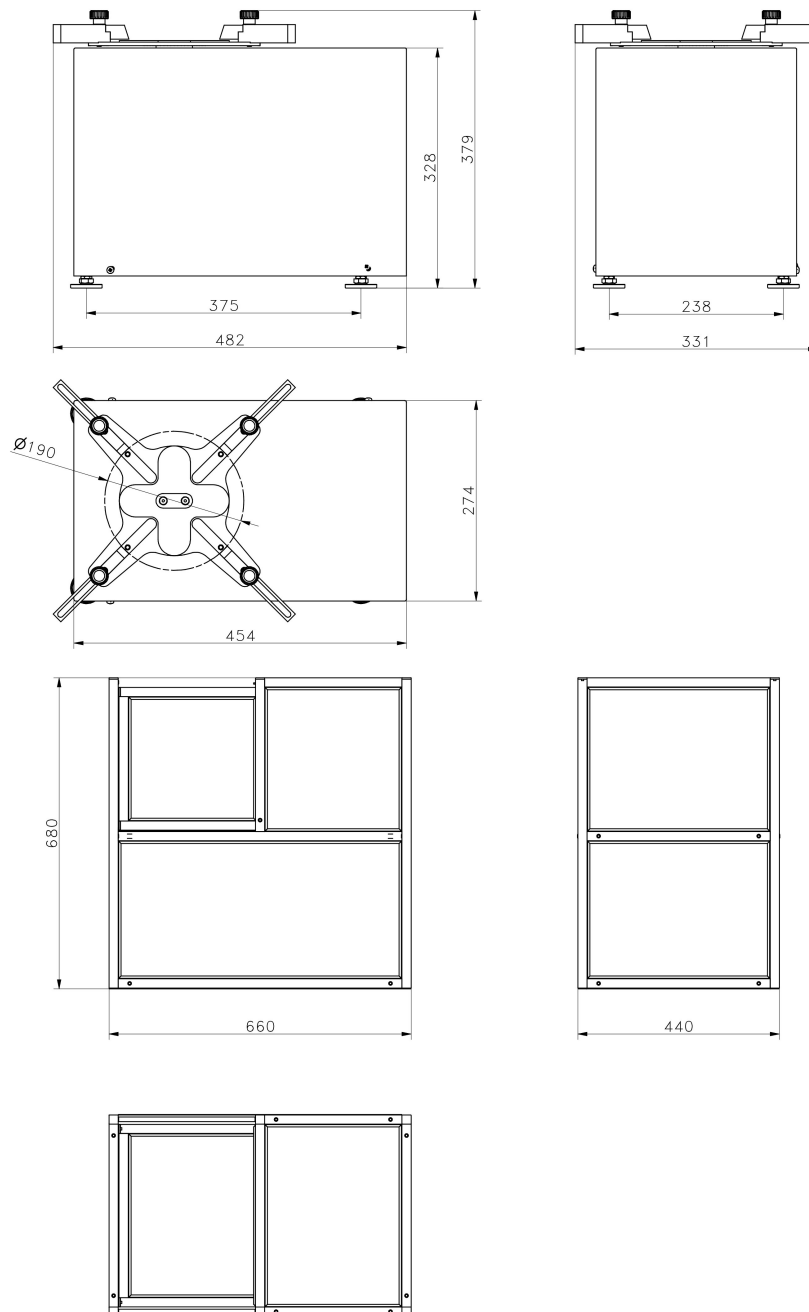

APP 10.5Y.KO Mass Comparator