



WLY 10/D2 Precision Balance

More information on the website
radwag.com/en/info,w1,E0G



WLY 10/D2 Precision Balance

The drawings, photos and graphics used are for illustrative purposes only.

Functions



Dosing



Labelling



Plus/Minus Control



Percent Weighing



Totalizing



Parts counting



Peak hold



Formulation



Newton unit measurement



Statistics



Checkweighing



IR sensors



Animal weighing



Differential weighing



ALIBI Memory

Datasheet

	WLY 10/D2 Precision Balance
Metrological parameters	
Maximum capacity [Max]	10 kg
Minimum load	-
Readability [d]	0,1 g
Verification unit [e]	-
Tare range	-10 kg
Repeatability	0,3 g
Linearity	±0,3 g
Stabilization time	3 s
Adjustment	external
OIML Class	-
Physical parameters	
Leveling system	manual
Weighing pan dimensions	195×195 mm
Packaging dimensions	530×310×150 mm
Net weight	2,7 kg
Gross weight	3,6 kg
Construction	
Protection class	IP 43
Communication interface	
Communication interface	2×RS232, 2×USB-A, Ethernet, 4 IN / 4 OUT (digital), Wi-Fi
Electrical parameters	
Power supply	Adapter: 100 – 240V AC 50/60Hz 1A; 15V DC 2,4A Balance: 10 – 28V DC 1A max
Environmental conditions	
Operating temperature	+15 ÷ +30 °C
Storage temperature	-25 - +70 °C
Relative humidity	10% ÷ 85% RH no condensation

Repeatability is expressed as a standard deviation from 10 weighing cycles. Stabilization time depends on the ambient conditions and the dynamics of weighing pan loading; specified for FAST profile.

* Wi-Fi® is a registered trademark of Wi-Fi® Alliance.



Accessories

Antivibration Tables
Transponder card readers
Power Adapters
RS 232 cables (scale - printer)
Cigarette lighter receptacle power supply cables
Barcode scanners
RS 232, RS 485 cables
Label Printers
Additional modules
Displays

IN/OUT Cables
Keypad, external switches
Stands, wall mounting kits and mounting brackets
Receipt Printer
F1 Mass Standard - knob weights without adjustment chamber, set
AP2-1 Current Loop Unit
RS 232, RS 485 cables
Additional Weighing platforms Module
RS 232 – USB Converter
RS 232 cables (scale - printer)

Software

E2R System
Audit Trail Reader
RADWAG Remote Desktop
Scales Editor 2.1

RAD-KEY
Label Editor R02
R-LAB
RADWAG Development Studio

Device dimensions

WLY 10/D2 Precision Balance

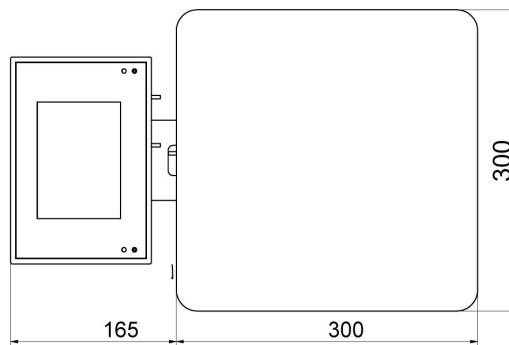
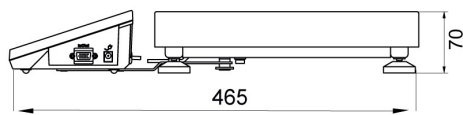

F1 version

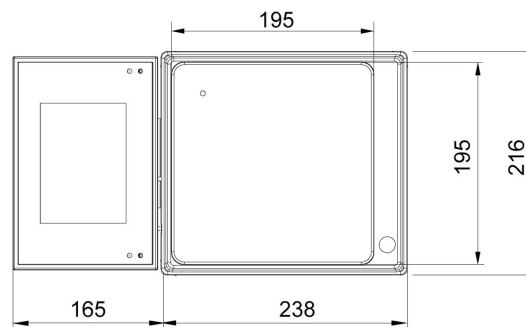
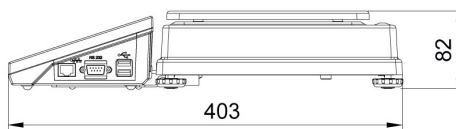

D2 version

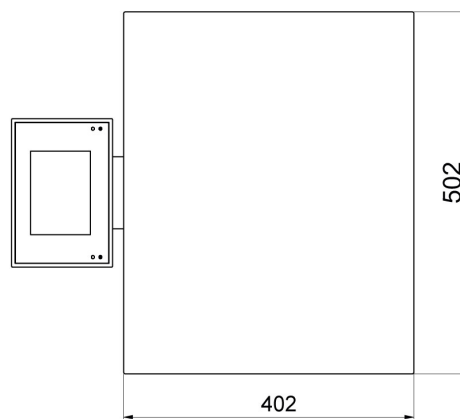

C2 version