



More information on the website
radwag.com/en/info,w1,1KV

PUE 7.1.150.HRP High Resolution Scale



PUE 7.1.150.HRP High Resolution Scale

The drawings, photos and graphics used are for illustrative purposes only.

Datasheet

	PUE 7.1.150.HRP High Resolution Scale
Metrological parameters	
Maximum capacity [Max]	150 kg
Minimum load	50 g
Preload range	30 kg
Readability [d]	1 g
Tare range	-150 kg
Repeatability	0,6 g
Linearity	±3 g
Stabilization time	3 s
Adjustment	internal (automatic)
Physical parameters	
Display	5,7" Resistiv-Farb-Touchscreen
Weighing pan dimensions	500×400 mm
Device dimensions	360×313×170 mm
Packaging dimensions	610×710×275 mm
Net weight	71,5 kg
Gross weight	119 kg
Construction	
Protection class	IP 66/67 construction, IP 43 indicator
Construction	mild steel St3S
Weighing pan material	Stainless steel AISI304
Communication interface	
Communication interface	2×RS232, 2×USB-A, Ethernet, 4 IN / 4 OUT (digital), Wi-Fi
Electrical parameters	
Power supply	100 – 240 V AC 50/60 Hz
Environmental conditions	
Operating temperature	+10 ÷ +40 °C
Relative humidity	40% ÷ 80%

Repeatability is expressed as the standard deviation of ten load placements. Relative humidity under non-condensing conditions. Stabilization time under optimal environmental conditions.

* Wi-Fi® is a registered trademark of Wi-Fi® Alliance.



Accessories

Displays
 Transponder card readers
 RS 232 cables (scale - Ethernet)

RS 232 cables (scale - printer)
 Receipt Printer
 Additional Weighing platforms Module

Software

E2R System
 RADWAG Remote Desktop

Label Editor R02
 Scales Editor 2.1

Device dimensions

PUE 7.1.150.HRP High Resolution Scale

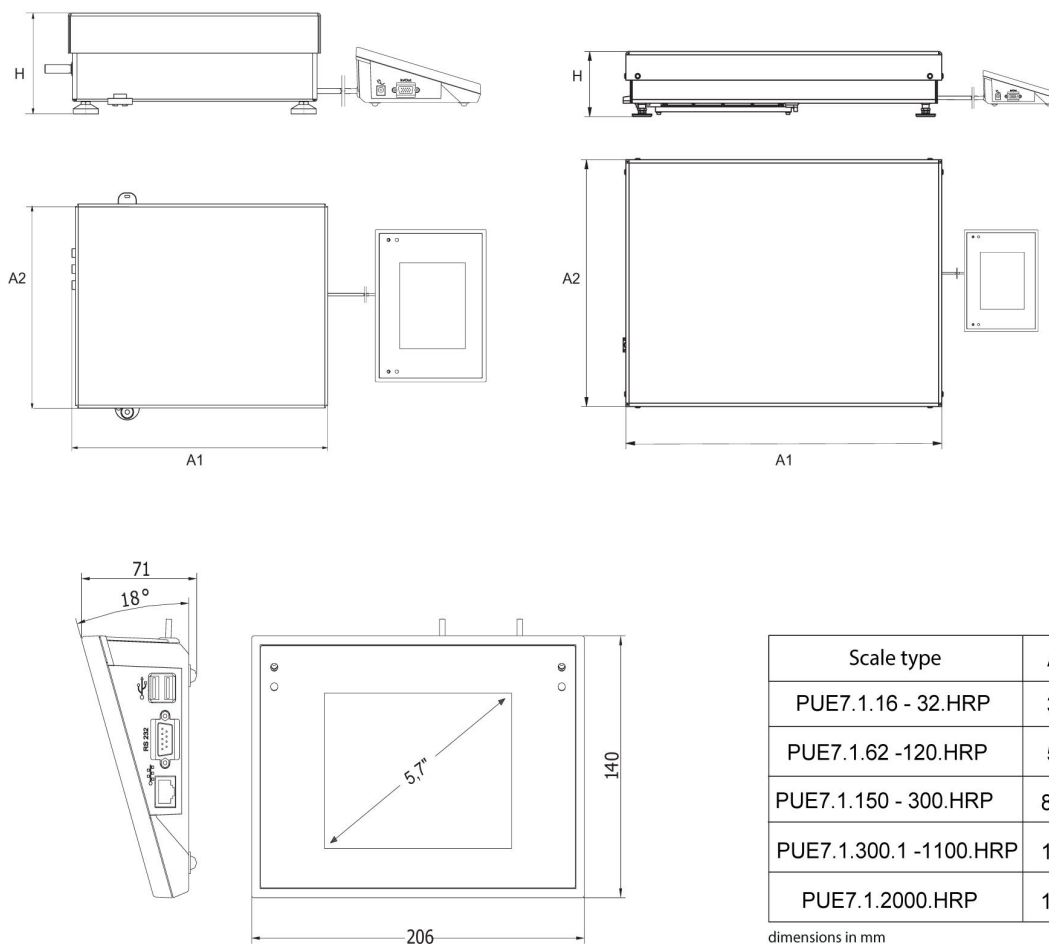

Scale type	A1	A2	H
PUE7.1.16 - 32.HRP	360	280	139±3
PUE7.1.62 -120.HRP	500	500	175±3
PUE7.1.150 - 300.HRP	800	600	175±3
PUE7.1.300.1 -1100.HRP	1000	800	175±3
PUE7.1.2000.HRP	1250	1000	175±3

dimensions in mm