



More information on the website
radwag.com/us/info,w1,ZYK

WLC 0,6/A1/C/2/IO Precision Balance



The drawings, photos and graphics used are for illustrative purposes only.

Functions



Plus/Minus Control



Percent Weighing



Totalizing



Parts counting



Internal battery



Peak hold



Newton unit measurement

Datasheet

Maximum capacity [Max]	0,6 kg
Minimum load	0,5 g
Readability [d]	0,01 g
Verification unit [e]	0,1 g
Tare range	-0,6 kg
Repeatability	0,015 g
Linearity	±0,02 g
Stabilization time	3 s
Adjustment	internal (automatic)
OIML Class	II

Physical parameters	
Leveling system	manualny
Display	LCD (backlit)
Weighing pan dimensions	128×128 mm
Packaging dimensions	430×270×190 mm
Net weight	3,6 kg
Gross weight	4,5 kg
Construction	
Protection class	IP 43
Communication interface	2×RS232, USB-A, USB-B, 4 IN / 4 OUT
Power supply	Adapter: 100 – 240V AC 50/60Hz 0,6A; 12V DC 1,2A Balance: 10 – 15VDC 0,6A max
Operation time on batteries	15 h (average time)
Operating temperature	+15 ÷ +30 °C
Relative humidity	10% ÷ 85% RH no condensation



Extra payment for verification



Accessories

!Balance Storage Case
 Antivibration tables
 Power Adapters
 RS 232 cables (scale - printer)
 Cigarette lighter receptacle power supply cables
 Under-pan weighing
 RS 232, RS 485 cables
 Draft Shield

RS 232 – Ethernet Converter
 Displays
 Receipt Printer
 AP2-1 Current Loop Unit
 Protective cover for balances
 RS 232, RS 485 cables
 RS 232 cables (scale - printer)
 RS 232 – RS 485 Converter

Software

- RAD Key [WX-010-0005]
- Scale Editor - EWAG 2.1 [WX-010-0173]

- Alibi Reader PC Software [WX-010-0114]

Device dimensions

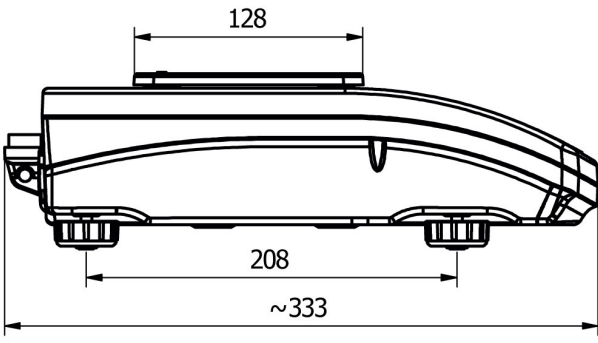

WLC A1

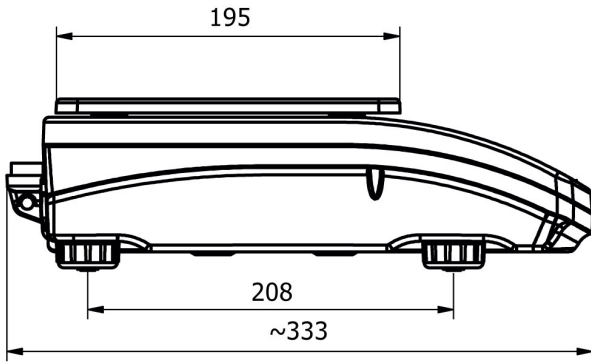
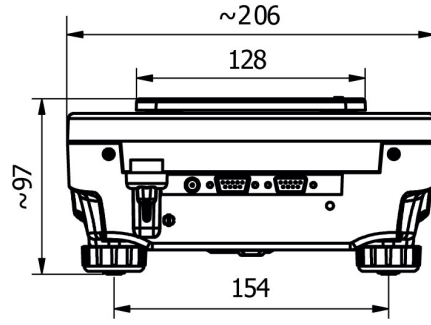

WLC A2

