



More information on the website
radwag.com/it/info,w1,ZYK

Bilancia di precisione WLC 0,6/A1/C/2/IO



The drawings, photos and graphics used are for illustrative purposes only.

Funzioni



Plus/Minus Control



Percent Weighing



Totalizing



Parts counting



Internal battery



Peak hold



Newton unit measurement



Under-pan weighing

Specifiche

Parametri metrologici	
Portata massima [Max]	0,6 kg
Portata minima [Min]	0,5 g
Divisione [d]	0,01 g
Intervallo di verifica della bilancia [e]	0,1 g
Campo di tara	-0,6 kg
Ripetibilita	0,015 g
Linearità	±0,02 g
Tempo di stabilizzazione	3 s
Calibrazione	internal (automatic)

Parametri metrologici	
Classe OIML	II
Parametri fisici	
Sistema di livellamento	manual
Display	LCD (backlit)
Dimensione piatto	128×128 mm
Dimensioni del pacco	430×270×190 mm
Peso netto	3,6 kg
Peso lordo	4,5 kg
Costruzione	
Punteggio IP	IP 43
Interfaccia di comunicazione	
Interfaccia	2×RS232, USB-A, USB-B, 4 IN / 4 OUT
Parametri elettrici	
Alimentatore	Adapter: 100 – 240V AC 50/60Hz 0,6A; 12V DC 1,2A Balance: 10 – 15VDC 0,6A max
Tempo operativo delle batterie	15 h (average time)
Environmental conditions	
Ambiente di lavoro	+15 ÷ +30 °C
Umidità relativa	10% ÷ 85% RH no condensation



Extra payment for verification



Accessori

Contenitore per stoccaggio bilance
 Tavoli antivibranti
 Alimentatore
 Cavo seriale RS 232 (connessione bilance - Stampanti)
 Cavo di alimentazione con spina per accendisigari
 Pesatura sottopensile
 Cavo seriale RS 232, RS 485
 Schermo di protezione

RS 232 – Ethernet Converter
 Display
 Stampanti di ricevuta
 AP2-1 Power loop output
 Capottina protettiva per bilance
 Cavo seriale RS 232, RS 485
 Cavo seriale RS 232 (connessione bilance - Stampanti)
 RS 232 – RS 485 Converter

Software

• RAD Key [WX-010-0005]
 • R-LAB [WX-010-0080]

• „Alibi Reader” PC Software [WX-010-0114]
 • Editore per sistemi di pesatura 2.1 [WX-010-0173]

Device dimensions



WLC A1

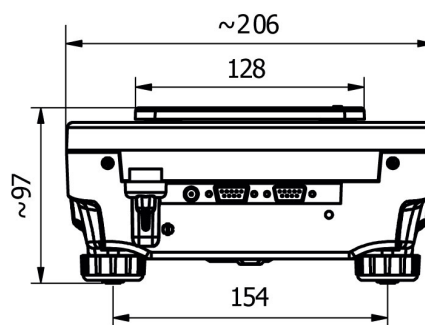

WLC A2

