



More information on the website  
[radwag.com/us/info,w1,ZAE](http://radwag.com/us/info,w1,ZAE)

# AS 220.R2 PLUS Analytical Balance



The drawings, photos and graphics used are for illustrative purposes only.

## Functions



Autotest



Dosing



Percent Weighing



Totalizing



Parts counting



Peak hold



Newton unit measurement



Statistics



Checkweighing



Under-pan weighing



GLP Procedures



Animal weighing



Density determination

## Datasheet

Maximum capacity [Max]	220 g
Minimum load	10 mg
Readability [d]	0,1 mg
Verification unit [e]	1 mg
Tare range	-220 g
Standard repeatability [5% Max]	0,07 mg

Standard repeatability [Max]	0,08 mg
Standard minimum weight (USP)	140 mg
Standard minimum weight (U=1%, k=2)	14 mg
Permissible repeatability [5% Max]	0,09 mg
Permissible repeatability [Max]	0,1 mg
Linearity	±0,2 mg
Stabilization time	2 s
Adjustment	internal (automatic)
OIML Class	I
<b>Physical parameters</b>	
Leveling system	manualny
Display	LCD (backlit)
Weighing chamber doors	manual
Delivery components	Balance, weighing pan, weighing pan shield, bottom cover, power supply.
Weighing pan dimensions	ø100 mm
Packaging dimensions	490×400×520 mm
Net weight	6,95 kg
Gross weight	9 kg
<b>Construction</b>	
Protection class	IP 43
Communication interface	2×RS232 <sup>1</sup> , 2×USB-A (interchangeable), USB-B, Wi-Fi (option)
Power supply	Adapter: 100 – 240V AC 50/60Hz 0,6A; 12V DC 1,2A Balance: 12 – 15V DC 0,4A max
Power consumption max.	3 W
Operating temperature	+10 ÷ +40 °C
Relative humidity	40% ÷ 80%

\* Wi-Fi® is a registered trademark of Wi-Fi® Alliance.



Extra payment for verification



## Accessories

Antivibration tables  
 Holders for laboratory flasks  
 Power Adapters  
 Cigarette lighter receptacle power supply cables  
 Density determination KIT  
 USB cable (scale - printer)  
 Professional Weighing Tables  
 Barcode scanners  
 Holders for test tubes and filters  
 Workstation for pipettes calibration

RS 232, RS 485 cables  
 Displays  
 Protective cover for balances  
 Weighing dishes  
 Antistatic ionizer  
 Receipt Printer  
 RS 232, RS 485 cables  
 Under-pan weighing  
 RS 232 cables (scale - printer)

# Software

- RAD Key [WX-010-0005]
- Alibi Reader PC Software [WX-010-0114]

- R Panel [WX-010-0187]
- RADWAG Development Studio [WX-010-0104]

# Device dimensions

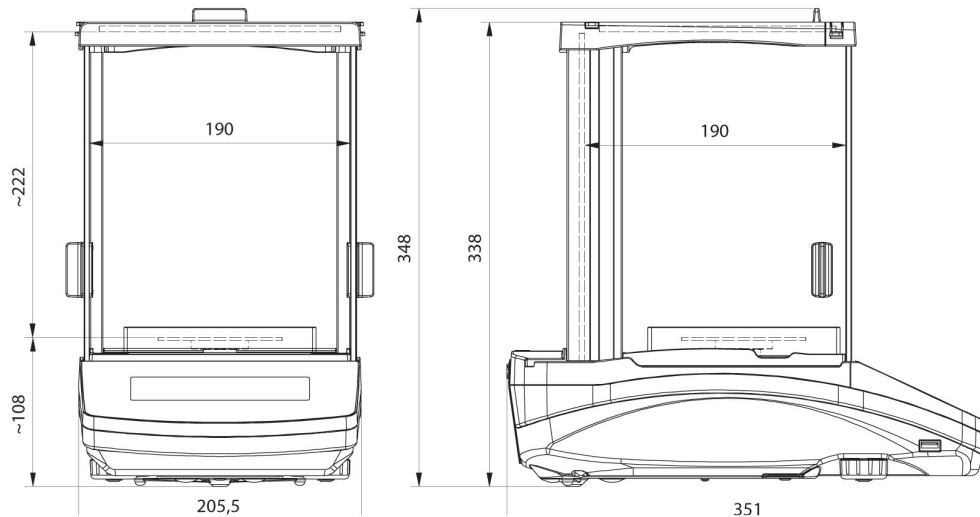

AS R2, d = 0.01 mg

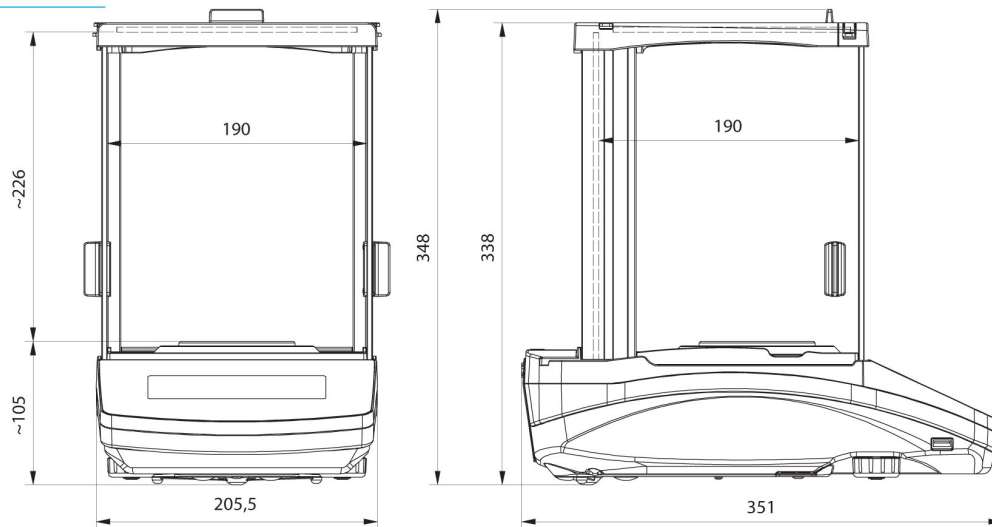

AS R2, AS R1 d = 0.1 mg