



More information on the website
radwag.com/us/info,w1,Z07

IM01.EX-3 Communication Module



The drawings, photos and graphics used are for illustrative purposes only.

Datasheet

Construction	
Protection class	IP 66 / 68 (1,5m)
Housing	aluminum
ATEX Certification	II (2)G [Ex ib] IIC Gb II (2)D [Ex ib] IIIC Db
Communication interface	2×RS232, USB, 4IN / 4OUT, Ethernet, 12 IN / 12 OUT (digital)
Power supply	100 – 240 V AC 50/60 Hz
Power consumption max.	10 W
Operating temperature	-10 – +40 °C
Storage temperature	-20 – +60 °C
Relative humidity	10% – 85% RH no condensation
Physical parameters	
Device dimensions	222×146×81 mm
Net weight	1,9 kg

Physical parameters

Gross weight

2,5 kg



Compatible with

HX5.EX-1.4P2 H Stainless steel Beam Scales
HX5.EX-1 HR Stainless Steel 1-Load-Cell Platform Scales
RS 232 cables (scale - printer)
HX5.EX-1.4P2 C Beam Scales
HX5.EX-1.4N Stainless Steel Ramp Scales
HX5.EX-1.4 C 4-Load-Cell Platform Scales
HX5.EX-1.4P H Stainless steel pallet scales
HX5.EX-1.4 H/Z Stainless steel platform scales, pit version
HX5.EX-1 C 1 Load Cell Platform Scales

HX5.EX-1 H Waterproof Platform Scales
PUE HX5.EX Weighing Terminal
HX5.EX-1.4 H Stainless Steel 4-Load-Cell Platform Scales
RS 232, RS 485 cables
IN/OUT Cables
HX5.EX-1.4P C Pallet scales
USB adapter
USB cable (scale - printer)
RS 232 – USB Converter

Device dimensions

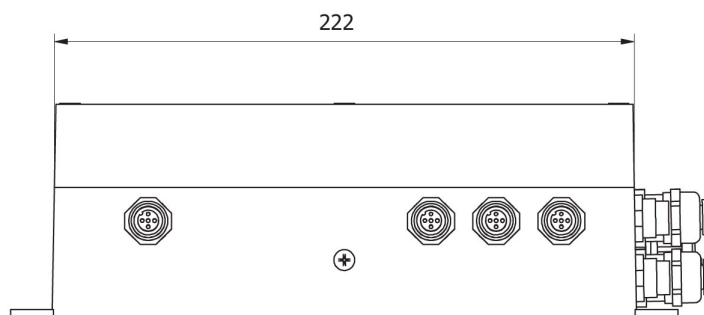
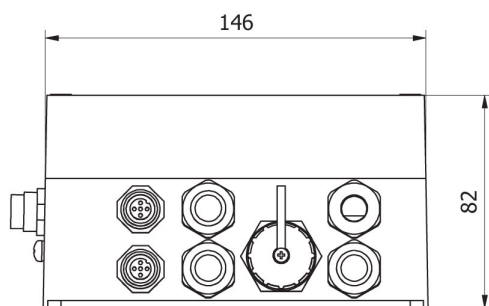

IM01.EX