



More information on the website  
[radwag.com/en/info,w1,YXA](https://radwag.com/en/info,w1,YXA)

# AS 120.R2 PLUS Analytical Balance



The drawings, photos and graphics used are for illustrative purposes only.

## Functions



Under-pan weighing

## Datasheet

Metrological parameters	
Maximum capacity [Max]	120 g
Minimum load	1 mg
Readability [d]	0.01 mg
Verification unit [e]	1 mg
Tare range	-120 g
Standard repeatability [5% Max]	0.012 mg
Standard repeatability [Max]	0.03 mg
Standard minimum weight (USP)	24 mg
Standard minimum weight (U=1%, k=2)	2.4 mg
Permissible repeatability [5% Max]	0.02 mg
Permissible repeatability [Max]	0.05 mg

Metrological parameters	
Linearity	±0.07 mg
Stabilization time	2 s
Adjustment	internal (automatic)
OIML Class	I
Physical parameters	
Leveling system	manual
Display	LCD (backlit)
Weighing chamber doors	manual
Delivery components	Balance, weighing pan, weighing pan shield, centring ring, bottom cover, power supply, fabric dust cover.
Weighing pan dimensions	ø90 open-work pan + ø85 (option) mm
Packaging dimensions	545×455×575 mm
Net weight	7.04 kg
Gross weight	10 kg
Construction	
Protection class	IP 43
Communication interface	
Communication interface	2×RS232 <sup>1</sup> , 2×USB-A (interchangeable), USB-B, Wi-Fi (option)
Electrical parameters	
Power supply	Adapter: 100 – 240V AC 50/60Hz 0.6A; 12V DC 1.2A Balance: 12 – 15V DC 0.4A max
Power consumption max.	3 W
Environmental conditions	
Operating temperature	+10 – +40 °C
Relative humidity	40% – 80%

**Repeatability** is expressed as a standard deviation from 10 weighing cycles.

**Stabilization time** depends on the ambient conditions and the dynamics of weighing pan loading; specified for FAST profile.

<sup>1</sup> Barcode scanners, available as weighing instrument accessory, communicate with the instrument via RS232 interface exclusively.

\* Wi-Fi® is a registered trademark of Wi-Fi® Alliance.



Extra payment for verification



## Accessories

Antivibration Tables  
Power Adapters  
Cigarette lighter receptacle power supply cables  
Density determination KIT  
USB cable (scale - printer)  
Professional Weighing Tables  
Barcode scanners  
Workstation for Pipettes Calibration  
RS 232, RS 485 cables

Displays  
Protective cover for balances  
Weighing dishes  
Antistatic ionizer  
Receipt Printer  
RS 232, RS 485 cables  
Under-pan weighing  
RS 232 cables (scale - printer)

# Software

- RAD Key [WX-010-0005]
- Alibi Reader [WX-010-0114]
- RADWAG Development Studio [WX-010-0104]
- R-Panel [WX-010-0187]
- R-Lab [WX-010-0080]

# Device dimensions

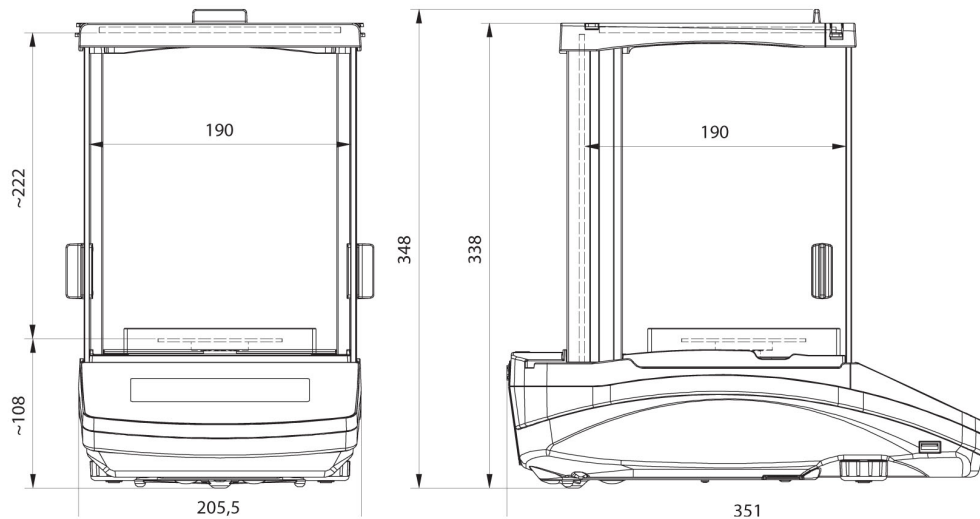

AS R2, d = 0.01 mg

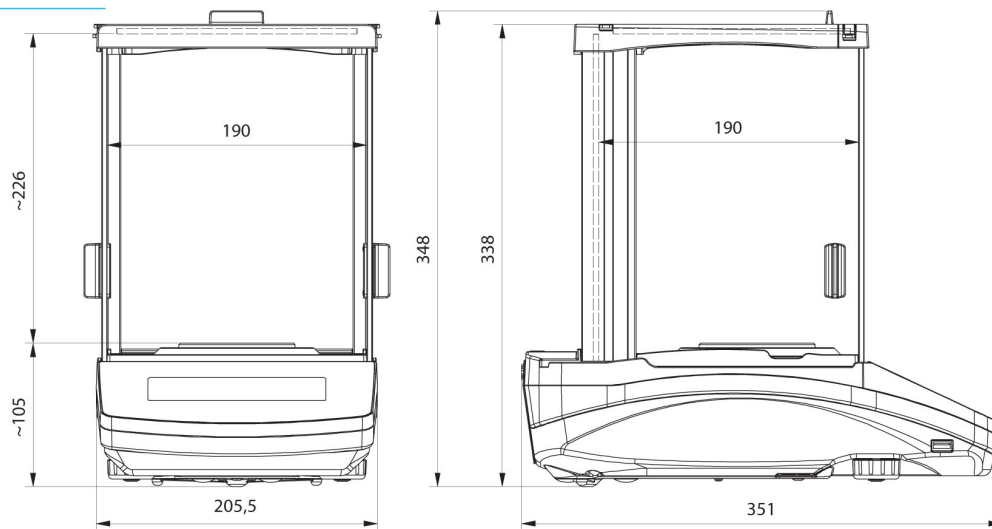

AS R2, AS R1 d = 0.1 mg