



















More information on the website
radwag.com/es/info,w1,YHV

Balanza WLY 60.C2.K.CCE



The drawings, photos and graphics used are for illustrative purposes only.

Funciones

-  Dosificación
-  Etiquetado
-  Indicador más/menos
-  Desviaciones porcentuales
-  Suma de pesajes
-  Contar piezas
-  Cierre del pesaje máximo
-  Recetas
-  Medición en Newtons
-  Estadísticas
-  Controlador de peso
-  Sensores infrarrojos
-  Pesaje de animales
-  Pesaje diferencial
-  Control de productos envasados
-  Memoria Alibi

Datos técnicos

Parámetros metrológicos	
Maxima capacidad [Max]	60 kg
Minima capacidad	0,5 kg
Legibilidad [d]	10 g
División de legalización [e]	10 g
Rango de tara	-120 kg
Repetibilidad	10 g

Parámetros metrológicos	
Linealidad	±10 g
Tiempo de estabilización	3 s
Calibración	externa
Clase OIML	II
Parámetros físicos	
Sistema de nivelación	manualny
Pantalla	5,7" Pantalla táctil resistiva en color
Dimensión de platillo	400×500 mm
Dimensiones de embalaje	720×620×210 mm
Masa neta	12,5 kg
Masa bruta	15 kg
Longitud del cable	2,5 m
Construcción	
Grado de protección	IP 43
Interface de comunicación	
Conectividad	2×RS232, 2×USB-A, Ethernet, 4 IN / 4 OUT (digitales), Wi-Fi
Parámetros electricos	
Alimentacion	Adapter: 100 – 240V AC 50/60Hz 1A; 15V DC 2,4A Balanza: 10 – 28V DC 1A max
Condiciones ambientales	
Temperatura de trabajo	+15 ÷ +30 °C
Temperatura de almacenamiento	-25 - +70 °C
Humedad relativa de aire	10% ÷ 85% RH sin condensación

* Wi-Fi® is a registered trademark of Wi-Fi® Alliance.



Accesorios

Lector de tarjetas transpondedor
 Adaptadores de corriente
 Cables RS 232 (Bascula a Impresora)
 Cables de corriente desde mechero de automóvil
 Escáner de códigos de barra
 Pasaje debajo del platillo
 Cables RS 232, RS 485
 Impresoras de etiquetas
 Módulos adicionales
 Pantallas

Cables Entradas/Salidas
 Teclado, manipuladores
 Soportes, brazos
 Impresoras de recibos
 Pesas de clase F1 - cilíndrico sin cámara de ajuste, juegos
 Salidas del bucle de corriente AP2-1
 Cables RS 232, RS 485
 Módulos adicionales de la plataforma
 Convertidor RS 232 a USB
 Cables RS 232 (Bascula a Impresora)

Programas

- E2R Pesajes [WX-010-0099]
- E2R Registro [WX-010-0038]
- Audit Trail Reader [WX-010-0186]

- E2R CCE [WX-010-0051]
- RAD Key [WX-010-0005]
- Editor de Etiquetas R02 [WX-010-0094]

- RADWAG Remote Desktop [WX-010-0107]
- Editor de Balanzas 2.1 [WX-010-0173]

- R-LAB [WX-010-0080]
- RADWAG Development Studio [WX-010-0104]

Dimensiones de aparato



F1 version



D2 version

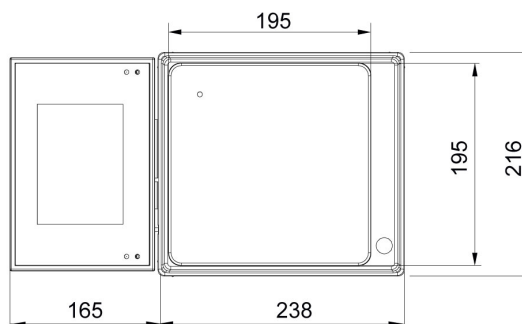

C2 version

