



More information on the website
radwag.com/tr/info,w1,Y6S

WLC 0,6/A1/C/2 Hassas Terazi



The drawings, photos and graphics used are for illustrative purposes only.

Fonksiyonlar



Plus/Minus Control



Percent Weighing



Totalizing



Parts counting



Internal battery



Peak hold



Newton unit
measurement



Under-pan weighing

Teknik Veriler

Metrolojik parametreler	
Maksimum yük [Max]	0,6 kg
Minimum yük [Min]	0,5 g
Okuma için ğruluđu [d]	0,01 g
Yasallaştırma birimi [e]	0,1 g
Dara aralığı	-0,6 kg
Tekrarlanabilirlik	0,015 g
Doğrusallık	±0,02 g
Kararlılık süresi	3 s
Ayarlama	dahili (otomatik)

Metrolojik parametreler	
OIML sınıfı	II
Fiziksel parametreler	
Tesviye sistemi	manuel
Display	LCD (aydınlatma ile)
Tartım kefi boyutları	128x128 mm
Ambalaj boyutları	430x270x190 mm
Net ağırlık	3,6 kg
Brüt ağırlık	3,5 kg
Konstrüksiyon	
IP Sınıfı	IP 43
Haberleşme arayüzler	
Haberleşme arayüzü	2xRS232, USB-A, USB-B
Elektrik parametreleri	
Güç kaynağı	Adapter: 100 – 240V AC 50/60Hz 0,6A; 12V DC 1,2A Teraziler: 10 – 15VDC 0,6A max
Batarya ile çalışma süresi	15 saat (ortalama süre)
Çevresel koşullar	
Çalıştırma sıcaklığı	+15 – +30 °C
Atmosferik nem	10% – 85% RH yoğunlaşma yok

Tekrarlanabilirlik, kütle standardının 10 yerleşmesinin standart sapması olarak ifade edilir.

Kararlılık süresi dış koşullara ve kefiye yük yerleştirme dinamiklerine bağlıdır; FAST profili için belirtilmiştir.

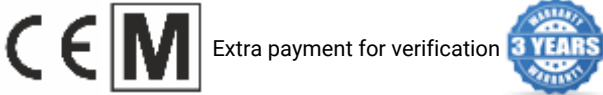

Aksesuarlar

Hassa terazi muhafaza çantası
Antivibrasyon masaları
Güç adaptörü
RS 232 cables (scale - printer)
Çakmak prizine uygun besleme kabloları
Panel altı tartım
RS 232, RS 485 cables
Draft Shield

RS 232 – Ethernet Converter
Display
Fiş yazıcı
AP2-1 Güç döngüsü çıkışı
Koruyucu kapak
RS 232, RS 485 Kabloları
Kablolar RS 232 (Teraziler - Yazıcı)
RS 232 – RS 485 Converter

Yazılım

• RAD Key [WX-010-0005]
• R-Lab [WX-010-0080]

• Alibi Okuyucu PC Yazılımı [WX-010-0114]
• Teraziler Editörü - EWAG 2.1 [WX-010-0173]

Cihaz boyutları

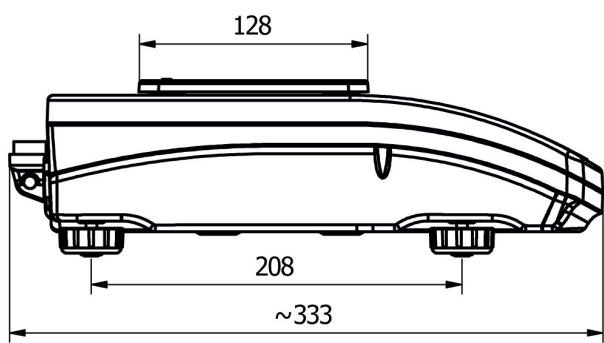

WLC A1



WLC A2

