



More information on the website
radwag.com/fr/info,w1,XWS

Balance de précision WLC 1/10.X7



The drawings, photos and graphics used are for illustrative purposes only.

Fonctions

-  Autotest
-  Dosing
-  Percent Weighing
-  Parts counting
-  Peak hold
-  Formulation
-  Newton unit measurement
-  Statistics
-  Checkweighing
-  IR sensors
-  Under-pan weighing
-  GLP Procedures
-  Animal weighing
-  Density determination
-  Ambient conditions monitoring
-  Replaceable unit
-  Statistical Quality Control
-  ALIBI Memory
-  Mass for titrator
-  Wi-Fi

Paramètres Techniques

Paramètres métrologiques	
Capacité maximale [Max]	10 kg
Précision de lecture	0,01 / 0,1 g
Échelon de légalisation [e]	-
Étendue de tare	-10 kg

Paramètres métrologiques	
Répétabilité	0,015 / 0,08 g
Linéarité	±0,03 / 0,3 g
Temps de stabilisation	4 / 2 s
Ajustage	externe
Paramètres physiques	
Système de nivellement	manualny
Afficheur	7" graphique couleurs écran tactile
Élément du kit	Balance, plateau, couvercle de plateau, vis de mise à la terre ×1, vis ×3, power supply.
Dimension du plateau	195×195 mm
Dimensions de colis	430×270×190 mm
Masse nette	2,2 kg
Masse brute	3,8 kg
Construction	
Degré de protection	IP 43
Composants et logiciels	
Bases de données	7
Interface de Communication	
Interface de Communication	2×RS232 ¹ , USB-A, USB-B, Ethernet, Wi-Fi
Paramètres électriques	
Alimentation	Adapter: 100 – 240V AC 50/60Hz 0,6A; 12V DC 1,2A Balance: 10 – 15VDC 0,6A max
Conditions environnementales	
Température du travail	+10 ÷ +40 °C

Répétabilité exprimée comme un écart standardisé de 10 placements de chargé.

Temps de stabilisation dépend de conditions externes et de la dynamique du placement d'un poids sur le plateau; déterminé pour le profil FAST

¹ Les scanners de codes-barres disponibles en accessoire coopèrent avec la balance en utilisant uniquement l'interface RS232.

* Wi-Fi® is a registered trademark of Wi-Fi® Alliance.



Accessoires

Valises pour balances
Tables antivibratoires
Alimentateurs
Câbles RS 232 (balance – imprimante)
Câbles d'alimentation de cigare-allume
Câble USB (balance – imprimante)
Lecteurs de code-barres
Pesage sous la balance

Câbles RS 232, RS 485
KIT pour déterminer la densité
Afficheurs
Imprimante de tickets de caisse
Câbles RS 232, RS 485
Écran de protection anti-poussière
Câbles RS 232 (balance – imprimante)
Convertisseur RS 232 – RS 485

Software

- RAD Key [WX-010-0005]
- R-LAB [WX-010-0080]
- RADWAG Studio du Développement [WX-010-0104]
- Alibi Reader [WX-010-0114]
- Éditeur de Balances 2.1 [WX-010-0173]

Dimensions d'appareil

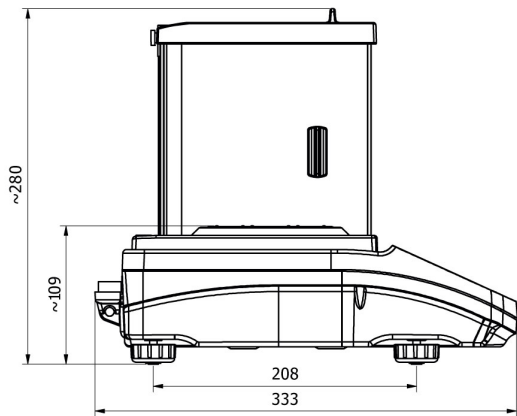

WLC X2, d = 0.001 mg

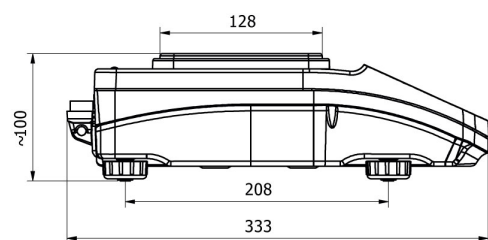
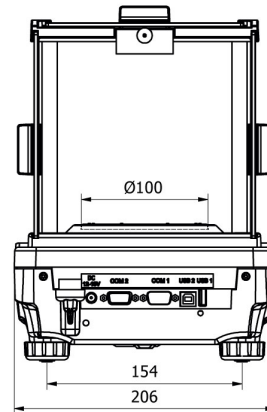

WLC X2, d = 0.01 mg

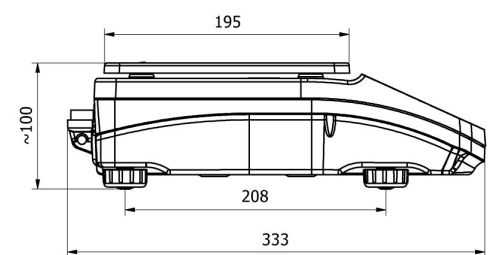
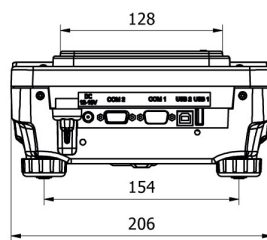

WLC X2, d = 0.1 mg

