

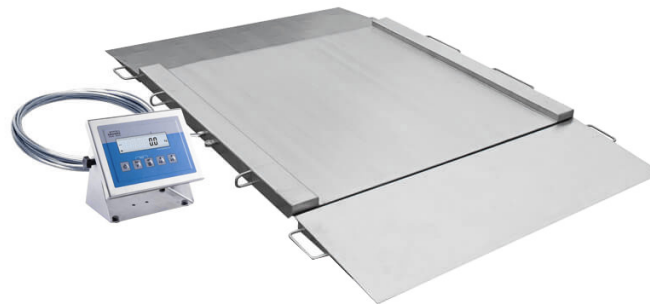

More information on the website
radwag.com/de/info,w1,XRK

Auffahrwaage H315.4N.300.H2



The drawings, photos and graphics used are for illustrative purposes only.

Funktionen



Plus/Minus Control



Percent Weighing



Totalizing



Parts counting



Internal battery



Peak hold



Newton unit measurement



Animal weighing

Technische Daten

Messtechnische Parameter

Wägebereich [Max]	300 kg
Min. Belastung	2 kg
Zifferschritt [d]	100 g
Tarierbereich	-300 kg
Max Ablesbarkeit [d] bei nicht geeichter Waage	20 g
OIML-Klasse	III

Physikalische Parameter

Display	LCD (hinterleuchtet)
Waagschale	1100×1200 mm

Physikalische Parameter	
Verpackungsgröße	1500×1300×600 mm
Gewicht der Waage mit Messgerät	150 kg
Kabellänge	3 m
Konstruktion	
Schutzart	IP 68 Konstruktion, IP 68 (1h max)/69 Messgerät
Kommunikationsschnittstellen	
Schnittstellen	RS232, USB
Optionale Schnittstellen	RS232 oder RS485 oder 4IN/4OUT oder Ethernet oder Analogausgang 4-20 mA
Elektrische Parameter	
Stromversorgung	100 – 240 V AC 50/60 Hz
Optionale Stromversorgung	interner Akkumulator
Akku-Betriebszeit	max 7h
Umgebungsbedingungen	
Umgebungstemperatur	-10 ÷ +40 °C
Relative Luftfeuchtigkeit	10% ÷ 85% RH ohne Kondensation



Extra payment for verification



Zubehör

Kabel RS 232 (Waage – Drucker)
Displays
Netzkabel (Waage – Ethernet)
Kabel RS 232, RS 485
Konverter RS 232 – Ethernet
USB-Adapter

Thermische Drucker
USB-Kabel (Waage – Drucker)
Stative, Ausleger
Konverter RS 232 – USB
Kabel RS 232, RS 485

Software

- RAD Key [WX-010-0005]
- RLAB [WX-010-0080]

- R Panel [WX-010-0187]
- Scale Editor 2.1 [WX-010-0173]

Abmessungen des Geräts



Model	Max	A	B	C	C1	D	E	F	G	H
H315.4N.150.H1	150 kg	840	860	45,5	76	1040	1710	778	940	1170
H315.4N.300.H1	300 kg	840	860	45,5	76	1040	1710	778	940	1170
H315.4N.600.H1	600 kg	840	860	45,5	76	1040	1710	778	940	1170
H315.4N.150.H2	1500 kg	1100	1200	45,5	76	1300	2050	1118	1200	1430
H315.4N.300.H2	300 kg	1100	1200	45,5	76	1300	2050	1118	1200	1430
H315.4N.600.H2	600 kg	1100	1200	45,5	76	1300	2050	1118	1200	1430
H315.4N.1500.H2	1500 kg	1100	1200	52,5	76	1300	2150	1118	1200	1430
H315.4N.300.H3	300 kg	1200	1500	45,5	76	1400	2350	1418	1300	1530
H315.4N.600.H3	600 kg	1200	1500	45,5	76	1400	2350	1418	1300	1530
H315.4N.1500.H3	1500 kg	1200	1500	52,5	76	1400	2450	1418	1300	1530
H315.4N.300.H4	300 kg	1500	1500	52,5	76	1700	2450	1418	1600	1830
H315.4N.600.H4	600 kg	1500	1500	52,5	76	1700	2450	1418	1600	1830
H315.4N.1500.H4	1500 kg	1500	1500	52,5	76	1700	2450	1418	1600	1830