



More information on the website
radwag.com/us/info,w1,X2A

MPS 2000.Y Weighing Module

WX-016-0236



The drawings, photos and graphics used are for illustrative purposes only.

Datasheet

Maximum capacity [Max]	2000 g
Minimum load	20 mg
Readability [d]	1 mg
Tare range	-2000 g
Repeatability	0,5 mg
Linearity	±4 mg
Stabilization time	3 s
Adjustment	internal (automatic)
Physical parameters	
Display	5,7" Resistive Color Touchscreen
Weighing pan dimensions	ø115 mm
Device dimensions	293×190×112 mm
Packaging dimensions	610×340×285 mm
Net weight	4,8 kg

Construction	
Protection class	IP 32
Housing	aluminum
Communication interface	2×RS232, 2×USB-A, Ethernet, 4 IN / 4 OUT (digital), Wi-Fi
Power supply	100 – 240 V AC 50/60 Hz
Operating temperature	+10 – +40 °C
Relative humidity	40% – 80%

* Wi-Fi® is a registered trademark of Wi-Fi® Alliance.



Accessories (Additional Fee)

Antivibration tables
Professional Weighing Tables
RS 232, RS 485 cables

RS 232 – USB Converter
RS 232 cables (scale - printer)

Software (Additional Fee)

- RAD Key [WX-010-0005]
- RADWAG Development Studio [WX-010-0104]

- R Panel [WX-010-0187]

Device dimensions

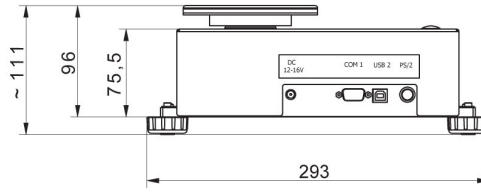
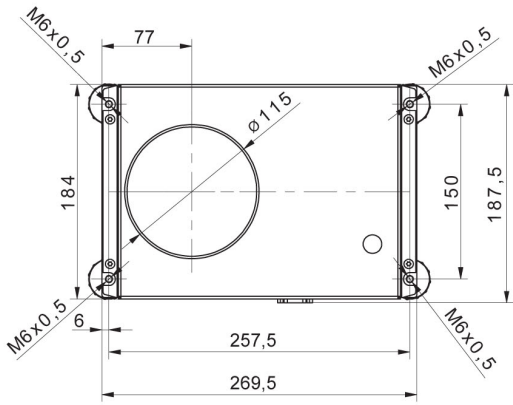

MPS

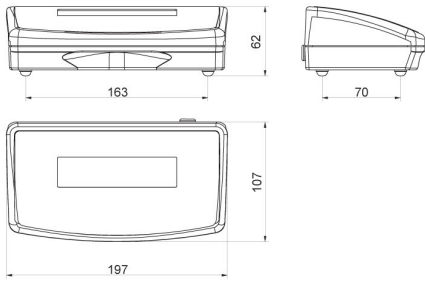

R operator panel

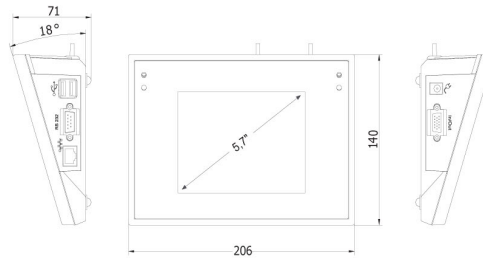

Y operator panel