



More information on the website
radwag.com/us/info,w1,X0B

PS 1000.R2.H Precision Balance



The drawings, photos and graphics used are for illustrative purposes only.

Functions

-  Autotest
-  Dosing
-  Percent Weighing
-  Totalizing
-  Parts counting
-  Peak hold
-  Newton unit measurement
-  Statistics
-  Checkweighing
-  Under-pan weighing
-  GLP Procedures
-  Animal weighing
-  Density determination

Datasheet

Maximum capacity [Max]	1000 g
Minimum load	20 mg
Readability [d]	0,001 g
Tare range	-1000 g
Repeatability (Max)	0,0015 g
Repeatability (5% Max)	0,0005 g

Linearity	±0,003 g
Stabilization time	2 s
Adjustment	internal (automatic)
Sensitivity temperature drift	$2 \times 10^{-6} / ^\circ\text{C} \times \text{Rt}$
Physical parameters	
Leveling system	manual
Display	LCD (backlit)
Weighing pan dimensions	∅100 mm
Packaging dimensions	475×380×345 mm
Net weight	4,5 kg
Gross weight	6 kg
Construction	
Protection class	IP 54
Communication interface	2×RS232 ¹ , USB-A, USB-B, Wi-Fi (option)
Power supply	Adapter: 100 – 240V AC 50/60Hz 0,6A; 12V DC 1,2A Balance: 12 – 15V DC 0,4A max
Power consumption	4 W
Operating temperature	+10 – +40 °C
Relative humidity	40% – 80%

* Wi-Fi® is a registered trademark of Wi-Fi® Alliance.



Accessories

Antivibration tables
Power Adapters
Cigarette lighter receptacle power supply cables
USB cable (scale - printer)
Barcode scanners
RS 232, RS 485 cables

Displays
Receipt Printer
RS 232, RS 485 cables
Protective cover for balances
Under-pan weighing
RS 232 cables (scale - printer)

Software

- RAD Key [WX-010-0005]
- Alibi Reader PC Software [WX-010-0114]
- R Panel [WX-010-0187]
- RADWAG Development Studio [WX-010-0104]

Device dimensions

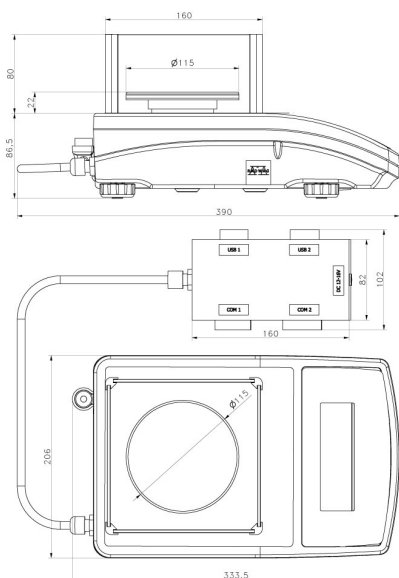

PS R2.H, d = 1 mg

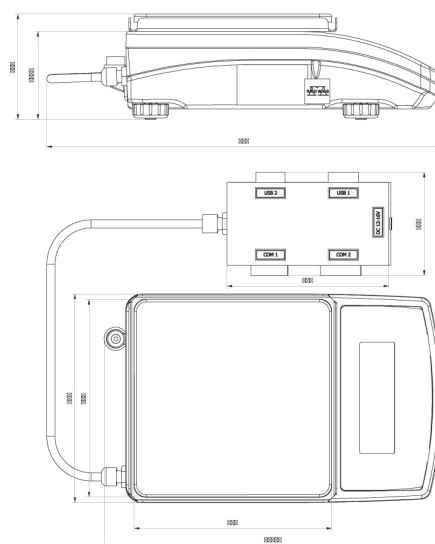

PS R2.M.H, d = 10 mg