



More information on the website
radwag.com/de/info,w1,WKD

Präzisionswaage PS 600.R1



The drawings, photos and graphics used are for illustrative purposes only.

Funktionen

-  Autotest
-  Dosing
-  Percent Weighing
-  Totalizing
-  Parts counting
-  Peak hold
-  Newton unit measurement
-  Statistics
-  Checkweighing
-  Under-pan weighing
-  GLP Procedures
-  Animal weighing
-  Density determination

Technische Daten

Messtechnische Parameter	
Wägebereich [Max]	600 g
Min. Belastung	20 mg
Zifferschritt [d]	0,001 g
Tarierbereich	-600 g
Wiederholbarkeit (Max)	0,0015 g
Wiederholbarkeit (5% Max)	0,0005 g

Messtechnische Parameter	
Linearität	±0,002 g
Stabilisierungszeit	2 s
Justierung	extern
Empfindlichkeitsdrift Temperatur	$2 \times 10^{-6} / ^\circ\text{C} \times \text{Rt}$
Physikalische Parameter	
Nivelliersystem	manuell
Display	LCD (hinterleuchtet)
Lieferumfang	Waage, Waagschale, Waagschalenabdeckung, Erdungsfuß ×1, Fußzeile ×3, Netzteil.
Waagschale	128×128 mm
Verpackungsgröße	475×380×345 mm
Nettogewicht	3,2 kg
Bruttogewicht	4,5 kg
Konstruktion	
Schutzart	IP 43
Kommunikationsschnittstellen	
Schnittstellen	2×RS232 ¹ , USB-A, USB-B, Wi-Fi (optional)
Elektrische Parameter	
Stromversorgung	Adapter: 100 – 240V AC 50/60Hz 0,6A; 12V DC 1,2A Waage: 12 – 15V DC 0,4A max
Leistungsaufnahme des Geräts	4 W
Umgebungsbedingungen	
Umgebungstemperatur	+10 ÷ +40 °C
Relative Luftfeuchtigkeit	40% ÷ 80%

Wiederholbarkeit wird als Standardabweichung von 10 Wägezyklen ausgedrückt.

Die Stabilisierungszeit ist abhängig von den Umgebungsbedingungen und der Geschwindigkeit bei Auflegen der Last auf der Waagschale; für FAST-Profil definiert.

¹ Barcode scanners, available as weighing instrument accessory, communicate with the instrument via RS232 interface exclusively.

* Wi-Fi® is a registered trademark of Wi-Fi® Alliance.



Zubehör

Waagenkoffer
 Antivibrationstische
 Netzteile
 Anschlusskabel für Zigarettenanzünder
 USB-Kabel (Waage – Drucker)
 Dichtebestimmungsset
 Barcodescanner
 Schrank für Waagen mit Waagschale 128×128mm

Kabel RS 232, RS 485
 Displays
 Windschutz
 Thermische Drucker
 Schutzhauben
 Kabel RS 232, RS 485
 Unterflurwägung
 Kabel RS 232 (Waage – Drucker)

Software

- RAD Key [WX-010-0005]
- Alibi Reader [WX-010-0114]
- RADWAG Development Studio [WX-010-0104]

- R Panel [WX-010-0187]
- RLAB [WX-010-0080]

Abmessungen des Geräts

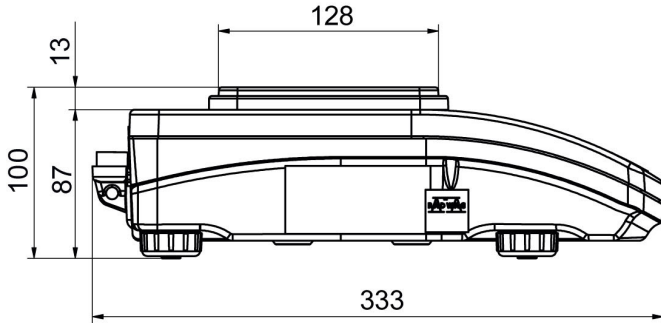

PS R, d = 1 mg

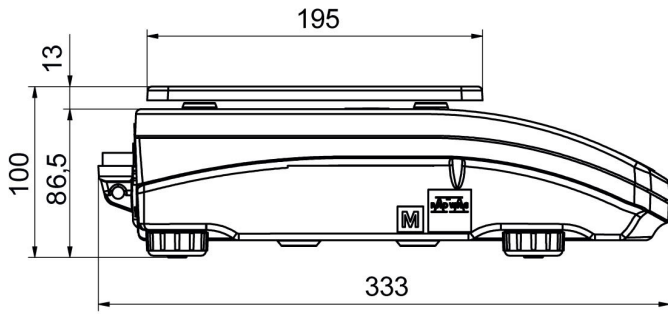
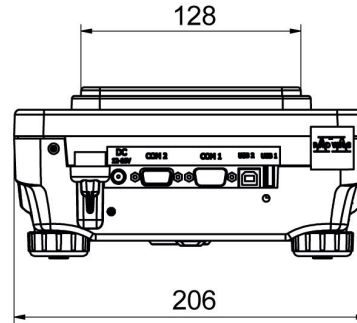

PS R, d = 10 mg

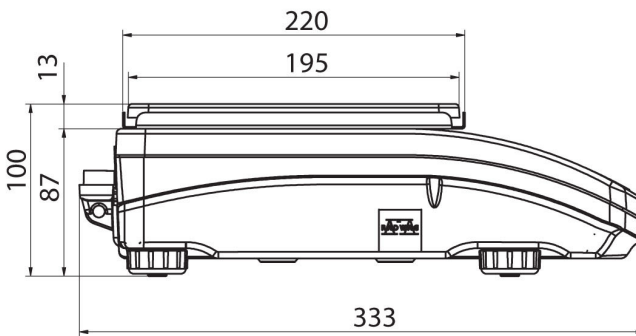
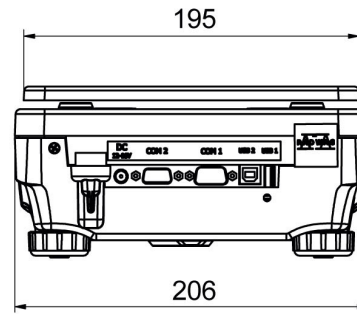

PS R.M, d = 10 mg

