



More information on the website
radwag.com/de/info,w1,W30

Präzisionswaage PS 210.R2



The drawings, photos and graphics used are for illustrative purposes only.

Funktionen



Autotest



Dosing



Percent Weighing



Totalizing



Parts counting



Peak hold



Newton unit measurement



Statistics



Checkweighing



GLP Procedures



Animal weighing



Density determination

Technische Daten

Messtechnische Parameter	
Wägebereich [Max]	210 g
Min. Belastung	20 mg
Zifferschritt [d]	1 mg
Eichwert [e]	10 mg
Tarierbereich	-210 g
Standard Wiederholbarkeit [5% Max]	0,5 mg
Standard Wiederholbarkeit [Max]	1 mg

Messtechnische Parameter	
Min. Einwaage (USP)	1 g
Min. Einwaage (U=1%, k=2)	0,1 g
Linearität	±2 mg
Stabilisierungszeit	2 s
Justierung	intern (automatisch)
OIML-Klasse	II
Empfindlichkeitsdrift Temperatur	$2 \times 10^{-6} / ^\circ\text{C} \times \text{Rt}$
Physikalische Parameter	
Nivelliersystem	manualny
Display	LCD (hinterleuchtet)
Lieferumfang	Waage, Waagschale, Waagschalenabdeckung, grounding bumper x1, bumper x3, Netzteil.
Waagschale	128x128 mm
Verpackungsgröße	475x380x345 mm
Nettogewicht	3,7 kg
Bruttogewicht	5 kg
Konstruktion	
Schutzart	IP 43
Kommunikationsschnittstellen	
Schnittstellen	2xRS232 ¹ , USB-A, USB-B, Wi-Fi (optional)
Elektrische Parameter	
Stromversorgung	Adapter: 100 – 240V AC 50/60Hz 0,6A; 12V DC 1,2A Waage: 12 – 15V DC 0,4A max
Leistungsaufnahme des Geräts	4 W
Umgebungsbedingungen	
Umgebungstemperatur	+10 ÷ +40 °C
Relative Luftfeuchtigkeit	40% ÷ 80%

Wiederholbarkeit wird als Standardabweichung von 10 Wägezyklen ausgedrückt.

Die Stabilisierungszeit ist abhängig von den Umgebungsbedingungen und der Geschwindigkeit bei Auflegen der Last auf der Waagschale; für FAST-Profil definiert.

¹ Barcode scanner, available as weighing instrument accessory, communicate with the instrument via RS232 interface exclusively.

* Wi-Fi® is a registered trademark of Wi-Fi® Alliance.



Extra payment for verification



Zubehör

Waagenkoffer
 Antivibrationstische
 Netzteile
 Anschlusskabel für Zigarettenanzünder
 USB-Kabel (Waage – Drucker)
 Dichtebestimmungsset
 Barcodescanner

Kabel RS 232, RS 485
 Displays
 Windschutz
 Thermische Drucker
 Schutzhauben
 Kabel RS 232, RS 485
 Unterflurwägung

Software

- RAD Key [WX-010-0005]
- Alibi Reader [WX-010-0114]
- RADWAG Development Studio [WX-010-0104]
- R Panel [WX-010-0187]
- RLAB [WX-010-0080]

Abmessungen des Geräts

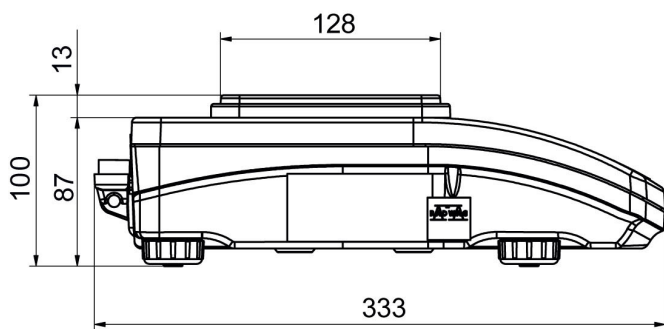

PS R, d = 1 mg

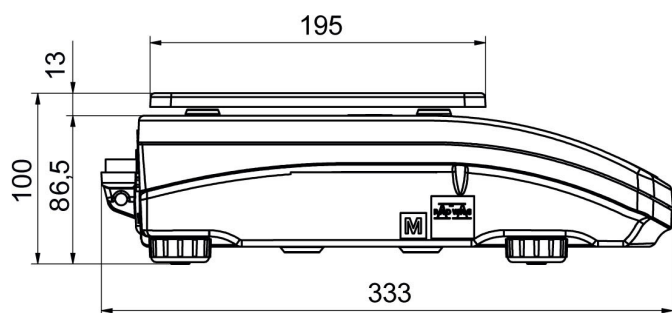
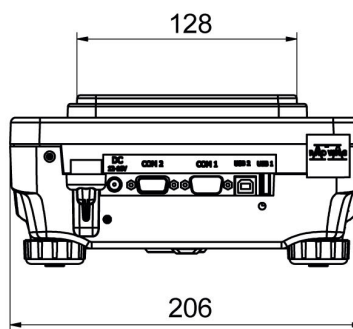

PS R, d = 10 mg

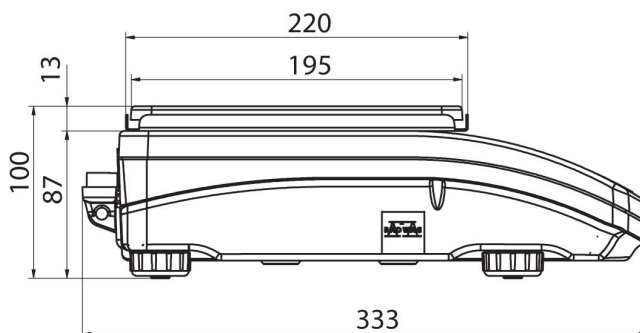
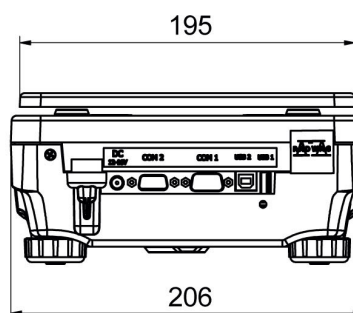

PS R.M, d = 10 mg

