

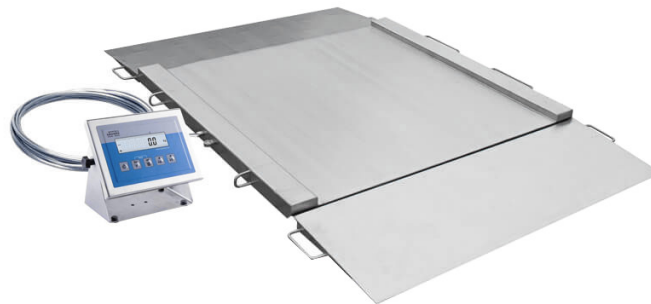

More information on the website
radwag.com/it/info,w1,VPU

Basamento in acciaio inox con rampa di carico H315.4N.1500.H3



The drawings, photos and graphics used are for illustrative purposes only.

Funzioni

 Plus/Minus Control

 Percent Weighing

 Totalizing

 Parts counting

 Internal battery

 Peak hold

 Newton unit measurement

 Animal weighing

Specifiche

Parametri metrologici

Portata massima [Max]	1500 kg
Portata minima [Min]	10 kg
Divisione [d]	500 g
Campo di tara	-1500 kg
Massima leggibilità per bilance non verificate	100 g
Classe OIML	III

Parametri fisici

Display	LCD (backlit)
Lunghezza del cavo	3 m

Parametri fisici	
Dimensione piatto	1200×1500 mm
Dimensioni del pacco	1600×1600×500 mm
Mass scala con indicatore	230 kg
Costruzione	
Punteggio IP	IP 68 construction, IP 68 (1h max)/69 terminal
Interfaccia di comunicazione	
Interfaccia	RS232, USB
Interfacce opzionali	RS232 or RS485 or 4IN/4OUT or Ethernet or analog output 4-20 mA
Parametri elettrici	
Alimentatore	100 – 240 V AC 50/60 Hz
Alimentatore opzionale	internal rechargeable battery
Tempo operativo delle batterie	max 7h
Environmental conditions	
Ambiente di lavoro	-10 – +40 °C
Umidità relativa	10% – 85% RH no condensation



Extra payment for verification



Accessori

Cavo seriale RS 232 (connessione bilance - Stampanti)
 Display
 Cavo seriale RS 232 (connessione bilance - Ethernet)
 Cavo seriale RS 232, RS 485
 RS 232 – Ethernet Converter
 USB adatper

Stampanti di ricevu
 cavo USB (connessione bilance - stampanti)
 Supporto, set di montaggio a muro e braccetti di montaggio
 RS 232 – USB Converter
 Cavo seriale RS 232, RS 485

Software

- RAD Key [WX-010-0005]
- R-LAB [WX-010-0080]

- R Panel [WX-010-0187]
- Editore per sistemi di pesatura 2.1 [WX-010-0173]

Device dimensions

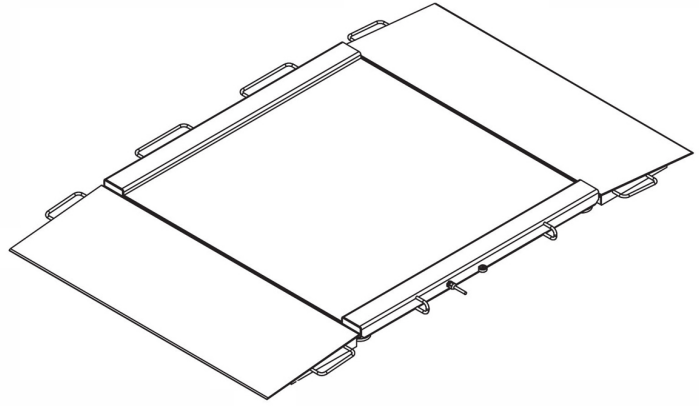

Model	Max	A	B	C	C1	D	E	F	G	H
H315.4N.150.H1	150 kg	840	860	45,5	76	1040	1710	778	940	1170
H315.4N.300.H1	300 kg	840	860	45,5	76	1040	1710	778	940	1170
H315.4N.600.H1	600 kg	840	860	45,5	76	1040	1710	778	940	1170
H315.4N.150.H2	1500 kg	1100	1200	45,5	76	1300	2050	1118	1200	1430
H315.4N.300.H2	300 kg	1100	1200	45,5	76	1300	2050	1118	1200	1430
H315.4N.600.H2	600 kg	1100	1200	45,5	76	1300	2050	1118	1200	1430
H315.4N.1500.H2	1500 kg	1100	1200	52,5	76	1300	2150	1118	1200	1430
H315.4N.300.H3	300 kg	1200	1500	45,5	76	1400	2350	1418	1300	1530
H315.4N.600.H3	600 kg	1200	1500	45,5	76	1400	2350	1418	1300	1530
H315.4N.1500.H3	1500 kg	1200	1500	52,5	76	1400	2450	1418	1300	1530
H315.4N.300.H4	300 kg	1500	1500	52,5	76	1700	2450	1418	1600	1830
H315.4N.600.H4	600 kg	1500	1500	52,5	76	1700	2450	1418	1600	1830
H315.4N.1500.H4	1500 kg	1500	1500	52,5	76	1700	2450	1418	1600	1830