



More information on the website  
[radwag.com/us/info,w1,VIL](http://radwag.com/us/info,w1,VIL)

# WAY 1200.5Y.KO Mass Comparator



The drawings, photos and graphics used are for illustrative purposes only.

## Datasheet

E1	-
E2	500 g ÷ 1 kg
F1	100 g ÷ 1 kg
F2	5 g ÷ 1 kg
M1	1 g ÷ 1 kg
M2	1 g ÷ 1 kg
Maximum capacity [Max]	1200 g
Readability [d]	0,1 mg
Standard repeatability [5% Max]	0,08 mg
Standard repeatability [Max]	0,1 mg
Permissible repeatability	0,2 mg
Eccentricity (tested load)	1d / 1 mm
Electric compensation range	0 g ÷ +1200 g
Stabilization time	10 s
Adjustment	internal

Physical parameters	
Display	10" graphic colour touchscreen
Weighing pan dimensions	ø80 mm
Weighing device dimensions	385×203×407 mm
Controlling device dimensions	249×170×72 mm
Anti-draft chamber dimensions	560×340×455 mm
Packaging dimensions	860×750×560 mm
Chamber packaging size	820×735×630 mm
Net weight	16 kg
Gross weight	31 kg
Supplementary weights internal	automatic
Supplementary weights external	Brak
Communication interface	2×USB-A, USB-C, HDMI, Ethernet, Wi-Fi, Hotspot
Operating temperature	+15 ÷ +30 °C
Operating temperature change rate	±0,5°C/12h (±0,3°C/4h)
Relative humidity	40% ÷ 60%
Relative humidity change rate	± 3 % / 4 h

\* Wi-Fi® is a registered trademark of Wi-Fi® Alliance.



## Accessories

### RFID Tags

Antivibration tables  
 Additional modules  
 Protective cover for balances  
 Barcode scanners  
 RS 232, RS 485 cables

### Label Printers

THBR 2.0 System - Ambient Conditions Monitoring  
 Receipt Printer  
 Fingerprint Reader  
 RS 232, RS 485 cables  
 RS 232 cables (scale - printer)

## Software

- RAD Key [WX-010-0005]
- RMCS System Network Management of Calibration Process [WX-010-0048]

- RMCS Lite [WX-010-0164]

## Device dimensions



WAY 5.5Y.KO

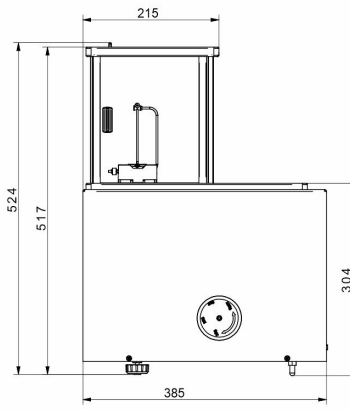
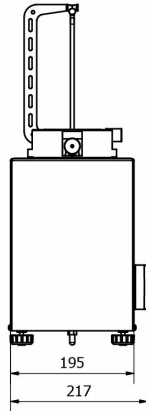

WAY 100.5Y.KO

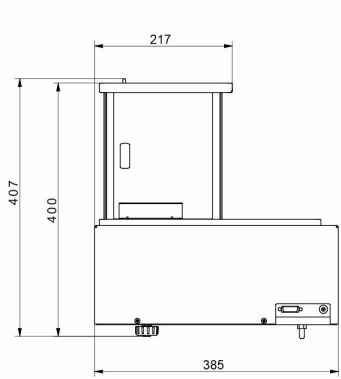
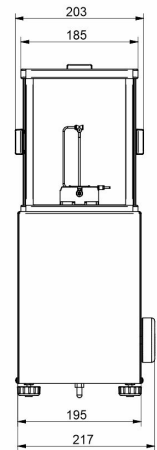

WAY 1200.5Y.KO

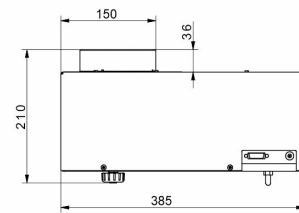
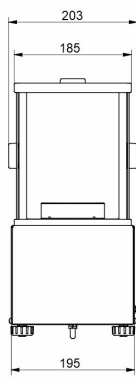

WAY 5100.5Y.KO

