



More information on the website
radwag.com/it/info,w1,UJR

Bilancia multi funzione HX7.60.H4



The drawings, photos and graphics used are for illustrative purposes only.

funzioni



Dosing



Percent Weighing



Parts counting



Formulation



Replaceable unit



ALIBI Memory

Foglio di calcolo

Parametri metrologici

| | |
|--|--------|
| Capacità massima [Max] | 60 kg |
| Pesata minima | 400 g |
| Accuratezza | 20 g |
| Intervallo di verifica della bilancia [e] | 20 g |
| Intervallo di tara | -60 kg |
| Massima leggibilità per bilance non verificate | 2 g |
| Classe OIML | III |

Parametri fisici

| | |
|---------|-------------------|
| Display | 7" graphic colour |
|---------|-------------------|

| Parametri fisici | |
|---------------------------------|---|
| Dimensioni del piatto di pesata | 500×500 mm |
| Dimensioni del pacco | 610×610×550 mm |
| Peso netto | 20,3 kg |
| Peso lordo | 24,6 kg |
| Costruzione | |
| Punteggio IP | IP 67 construction, IP 66/68 indicator |
| Tastiera | membrane |
| Costruzione | Stainless steel AISI304 |
| Materiale da pesata | Stainless steel AISI304 |
| Interfaccia di comunicazione | |
| Interfaccia | RS232, USB-A, 4IN, 4OUT, Ethernet, Modbus RTU |
| Interfacce opzionali | USB (M12 4P), Ethernet, module RS485, module RS232, module Profibus (Dp SLAVE), PROFINET (RRJ45), EtherNet/IP (RRJ45), 12 IN, 12 OUT, 4-20mA, 0-10V |
| Parametri elettrici | |
| Alimentatore | 100 – 240 V AC 50/60 Hz |
| Massimo assorbimento elettrico | 25 W |
| Alimentatore opzionale | 12-24V DC |
| Environmental conditions | |
| Temperatura di lavoro | -10 ÷ +40 °C |
| Temperatura di stoccaggio | -10 ÷ +50 °C |
| Umidità atmosferica | 10% ÷ 80% RH no condensation |
| Indicatore | PUE HX7 |
| Numero di pulsanti | 22 |
| Caratteristiche operative | |
| Numero massimo di piattaforme | 2 |



Extra payment for verification



Accessori

Cavo seriale RS 232 (connessione bilance - Stampanti)
 Banco a rulli
 Cavo seriale RS 232 (connessione bilance - Stampanti ZEBRA)
 Display
 Alimentatore
 Cavo seriale RS 232, RS 485
 cavo USB (connessione bilance - stampanti)
 cavi IN/OUT
 Lettore di codici a barre

stampanti per etichette
 Supporto, set di montaggio a muro e braccetti di montaggio
 Tastiera, interruttori esterni
 USB adapter
 Stampanti di ricevuata
 Moduli aggiuntivi della piattaforma
 RS 232 – USB Converter
 Moduli aggiuntivi

Software

- E2R Weighing [WX-010-0099]
- RAD Key [WX-010-0005]
- „Alibi Reader” PC Software [WX-010-0114]

- E2R Weighing Records [WX-010-0038]
- Editore di etichette R02 [WX-010-0094]
- R-LAB [WX-010-0080]

Device dimensions



H Platform

| | A1 | A2 | H |
|----------|-----|-----|-------|
| HX7.H1 | 200 | 150 | 85±3 |
| HX7.H2 | 250 | 300 | 103±3 |
| HX7.H3 | 410 | 410 | 98±2 |
| HX7.H4 | 500 | 500 | 155±5 |
| HX7.H3/5 | 400 | 600 | 155±5 |
| HX7.H5 | 600 | 600 | 155±5 |
| HX7.H6 | 800 | 800 | 135±5 |

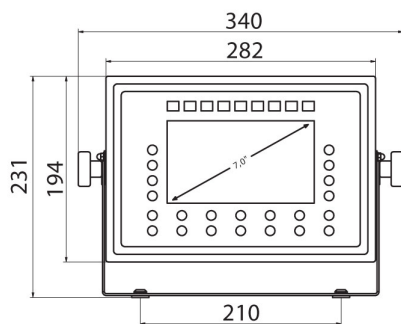
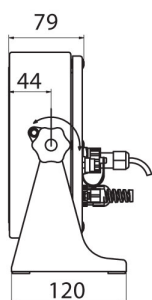

PUE HX7