

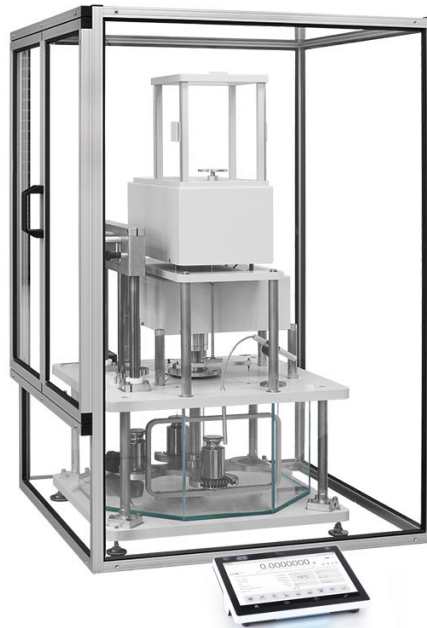

More information on the website  
[radwag.com/us/info,w1,T4L](http://radwag.com/us/info,w1,T4L)

# AGV-2 20.5Y Automatic Comparator



The drawings, photos and graphics used are for illustrative purposes only.

## Datasheet

E1	1 kg ÷ 20 kg
E2	1 kg ÷ 20 kg
F1	1 kg ÷ 20 kg
F2	1 kg ÷ 20 kg
Maximum capacity [Max]	26,1 kg
Readability [d]	1 mg
Standard repeatability [5% Max]	2 mg
Standard repeatability [Max]	3 mg
Permissible repeatability	6 mg
Electric compensation range	100 g ÷ +26,1 kg
Stabilization time	30 s
Adjustment	external
<b>Physical parameters</b>	
Display	10" graphic colour touchscreen
Magazine positions	automatic 2 positions

Physical parameters	
Weighing pan dimensions	ø220 mm self centering
Object diameters	25-145 mm
Power supply	100 – 240 V AC 50/60 Hz
Operating temperature	+15 ÷ +30 °C
Storage temperature	-20 ÷ +50 °C
Operating temperature change rate	±0,5°C/12h (±0,3°C/4h)
Relative humidity	40% ÷ 60%
Relative humidity change rate	±5%/12h (3%/4h)



## Accessories

RFID Tags  
 Additional modules  
 Protective cover for balances  
 Barcode scanners  
 RS 232, RS 485 cables

THBR 2.0 System - Ambient Conditions Monitoring  
 Receipt Printer  
 Fingerprint Reader  
 RS 232, RS 485 cables  
 RS 232 cables (scale - printer)

## Software

• RMCS Lite [WX-010-0164]

• RMCS System Network Management of Calibration Process [WX-010-0048]

## Device dimensions

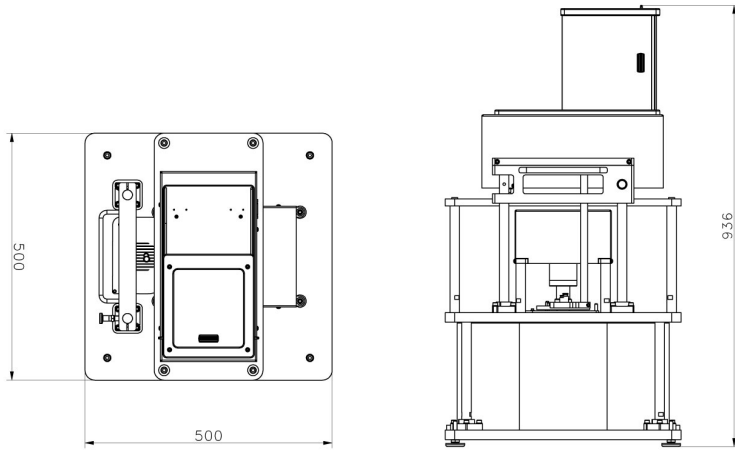

AGV-8/1000

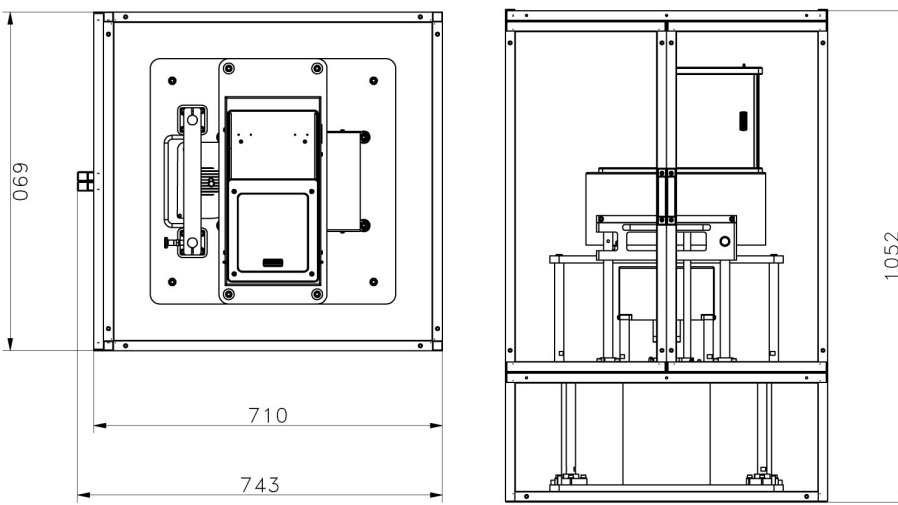

AGV-8/1000  
Anti-draft chamber ver.1

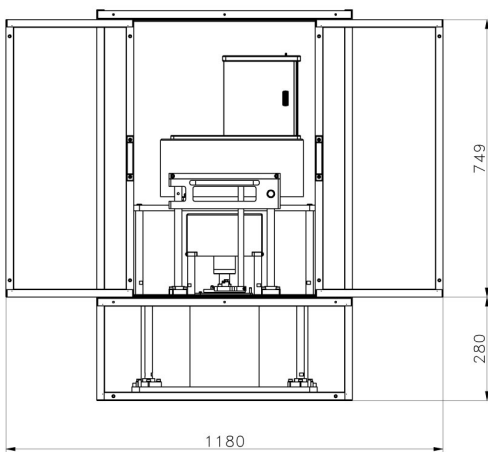

AGV-8/1000  
Anti-draft chamber ver.2