



More information on the website  
[radwag.com/it/info,w1,T45](http://radwag.com/it/info,w1,T45)

# Sistema di pesatura su rotaia H315.2K.300/600H



The drawings, photos and graphics used are for illustrative purposes only.

## Funzioni

 Plus/Minus Control

 Percent Weighing

 Totalizing

 Parts counting

 Internal battery

 Peak hold

 Newton unit measurement

 Animal weighing

## Specifiche

### Parametri metrologici

Portata massima [Max] 300 / 600 kg

Portata minima [Min] 2 kg

Divisione [d] 0,1 / 0,2 kg

Campo di tara -600 kg

Classe OIML III

### Parametri fisici

Display LCD (backlit)

Ampiezza della linea di controllo L= 800 mm (min. 200 mm)

Costruzione	
Punteggio IP	IP 67 construction, IP 68 (1h max)/69 terminal
Costruzione	Stainless steel AISI304
Interfaccia di comunicazione	
Interfaccia	RS232, USB
Interfacce opzionali	RS232 or RS485 or 4IN/4OUT or Ethernet or analog output 4-20 mA
Parametri elettrici	
Alimentatore	100 – 240 V AC 50/60 Hz
Alimentatore opzionale	internal rechargeable battery
Tempo operativo delle batterie	max 7h
Environmental conditions	
Ambiente di lavoro	-10 – +40 °C
Umidità relativa	10% – 85% RH no condensation



Extra payment for verification



## Accessori

Cavo seriale RS 232 (connessione bilance - Stampanti)  
 Display  
 Cavo seriale RS 232 (connessione bilance - Ethernet)  
 Cavo seriale RS 232, RS 485  
 RS 232 – Ethernet Converter  
 USB adatper

Stampanti di ricevuta  
 cavo USB (connessione bilance - stampanti)  
 Supporto, set di montaggio a muro e braccetti di montaggio  
 RS 232 – USB Converter  
 Cavo seriale RS 232, RS 485

## Software

- RAD Key [WX-010-0005]
- R-LAB [WX-010-0080]

- R Panel [WX-010-0187]
- Editore per sistemi di pesatura 2.1 [WX-010-0173]

## Device dimensions



**CAUTION**

- Standard version of the weighing track length:  $L = 800 \text{ mm}$
- The truck in the place of assembling the scale has to be horizontal with a  $\pm 10 \text{ mm}$  tilt limit
- The dimensions bearing the letters are to be agreed with contractor manufacturing Z dimension; the dimensions can be omitted if the following relation is fulfilled:  $Z \leq 80\% D$

Dimensions of an overhead track scale with a shaft of  $\varnothing 60$  (standard version)

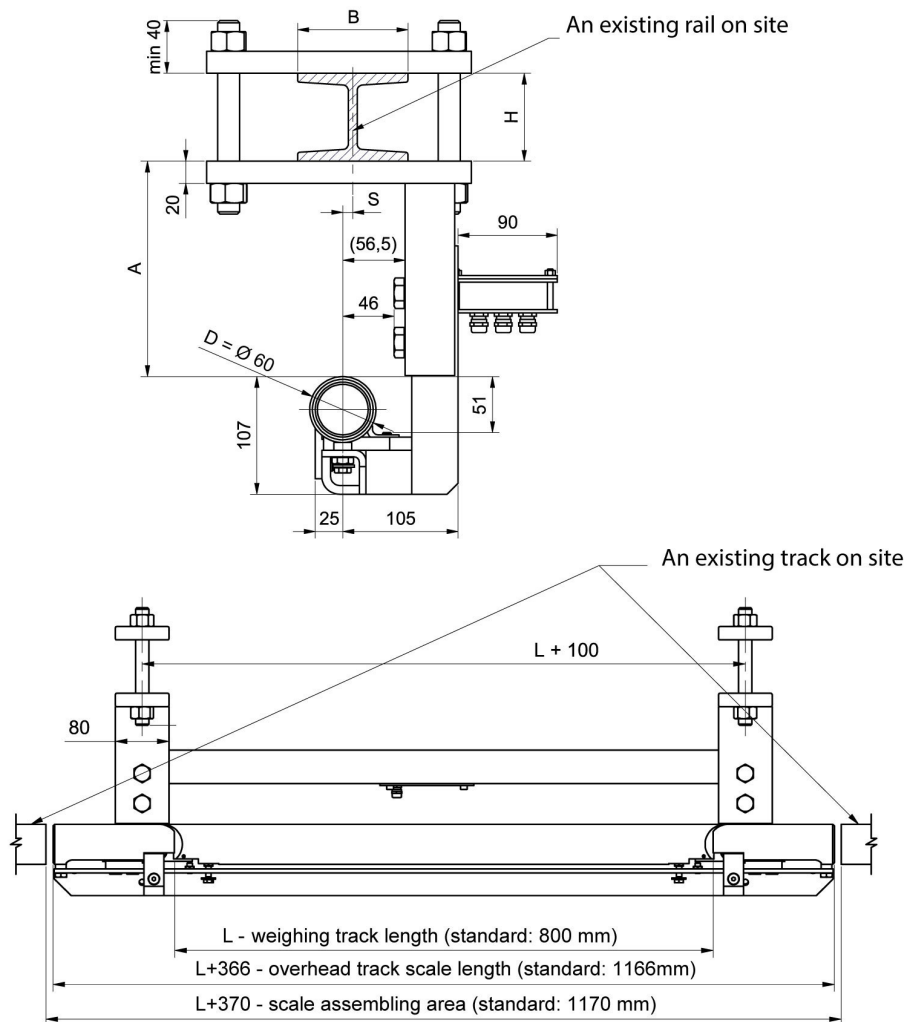

Minimum track clearance:  $A = 90 \text{ mm}$ .  
 Weighing track length:  $200 \leq L \leq 800 \text{ mm}$ . As a standard:  $L=800 \text{ mm}$ .  
 Maximum capacity:  $600 \text{ kg}$ .