



More information on the website
radwag.com/es/info,w1,T45

Báscula de carriles H315.2K.300/600H



The drawings, photos and graphics used are for illustrative purposes only.

Funciones

 Indicador más/menos

 Desviaciones porcentuales

 Suma de pesajes

 Contar piezas

 Batería interna

 Cierre del pesaje máximo

 Medición en Newtons

 Pesaje de animales

Datos técnicos

Parámetros metrológicos

Maxima capacidad [Max] 300 / 600 kg

Minima capacidad 2 kg

Legibilidad [d] 0,1 / 0,2 kg

Rango de tara -600 kg

Clase OIML III

Parámetros físicos

Pantalla LCD (con retroiluminación)

Longitud de la trayectoria de medición L= 800 mm (min. 200 mm)

Construcción	
Grado de protección	IP 67 construcción, IP 68 (1h max)/69 medidor
Construcción	Acero inoxidable AISI304
Interface de comunicación	
Conectividad	RS232, USB
Interfaces opcionales	RS232 o RS485 o 4IN/4OUT o Ethernet o entradas analógica 4-20 mA
Parámetros electricos	
Alimentacion	100 – 240 V AC 50/60 Hz
Corriente de alimentación adicional	batería interna
Horas de trabajo con baterías	max 7h
Condiciones ambientales	
Temperatura de trabajo	-10 – +40 °C
Humedad relativa de aire	10% – 85% RH sin condensación



Extra payment for verification



Accesorios

Cables RS 232 (Bascula a Impresora)
 Pantallas
 Cables de corriente (Bascula a Ethernet)
 Cables RS 232, RS 485
 Convertidor RS 232 a Ethernet
 Adaptadores USB

Impresoras de recibos
 Cable USB (Bascula a Impresora)
 Soportes, brazos
 Convertidor RS 232 a USB
 Cables RS 232, RS 485

Programas

- RAD Key [WX-010-0005]
- R-LAB [WX-010-0080]

- R Panel [WX-010-0187]
- Editor de Balanzas 2.1 [WX-010-0173]

Dimensiones de aparato

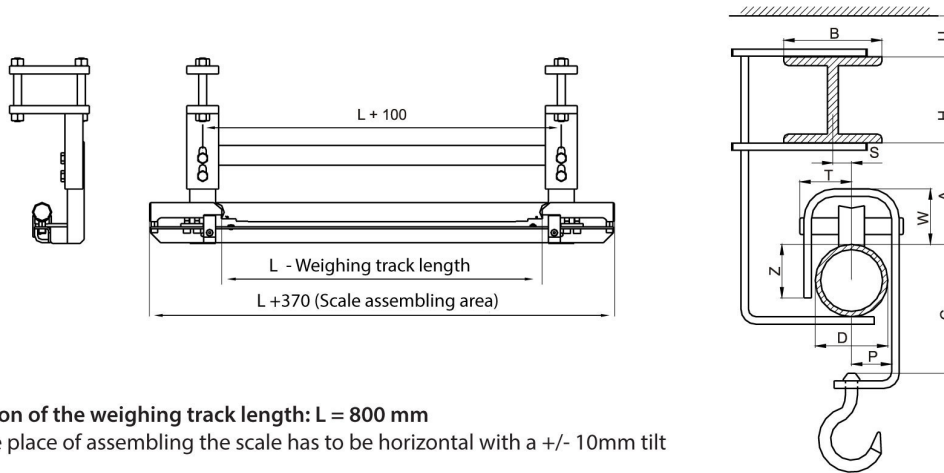

CAUTION

- Standard version of the weighing track length: $L = 800 \text{ mm}$
- The truck in the place of assembling the scale has to be horizontal with a $\pm 10 \text{ mm}$ tilt limit
- The dimensions bearing the letters are to be agreed with contractor manufacturing Z dimension; the dimensions can be omitted if the following relation is fulfilled: $Z \leq 80\% D$

Dimensions of an overhead track scale with a shaft of $\varnothing 60$ (standard version)

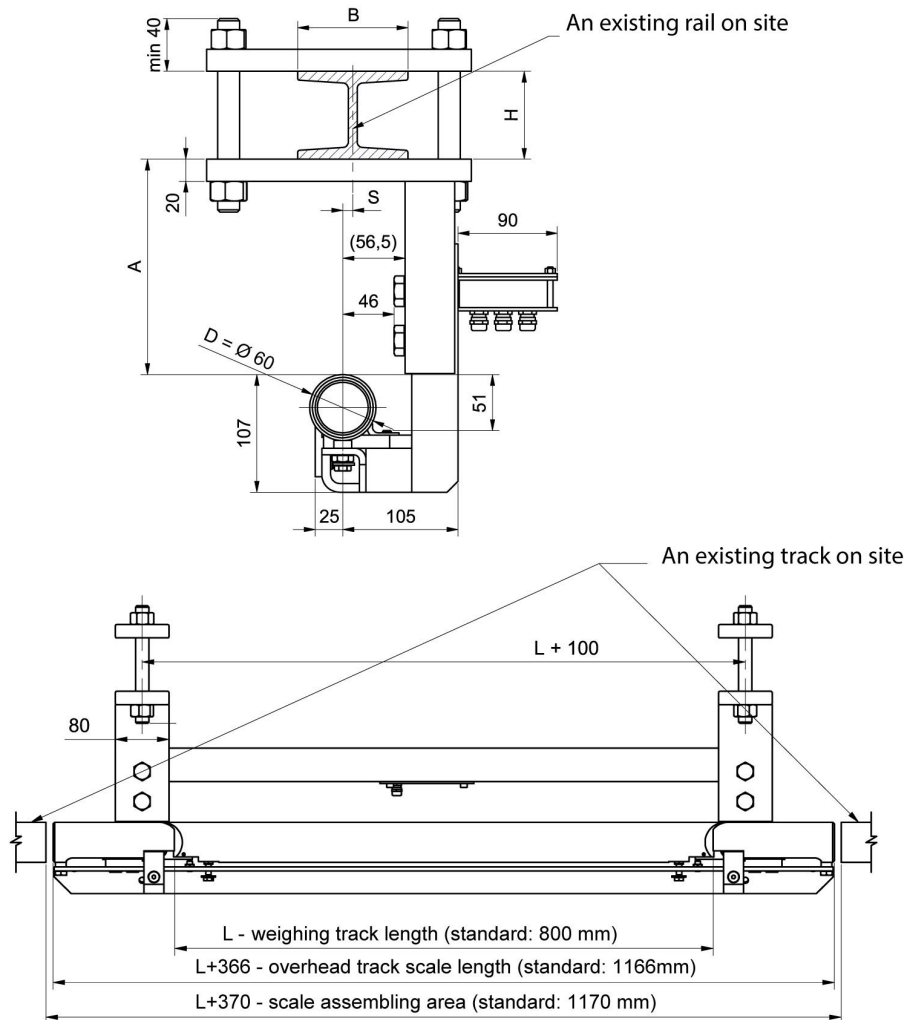

Minimum track clearance: $A = 90 \text{ mm}$.
 Weighing track length: $200 \leq L \leq 800 \text{ mm}$. As a standard: $L=800 \text{ mm}$.
 Maximum capacity: **600 kg**.