



# Balance multifonctionnelle HY10.15.F1.K

WP-116-0003

More information on the website  
[radwag.com/fr/info,w1,S6F](http://radwag.com/fr/info,w1,S6F)



The drawings, photos and graphics used are for illustrative purposes only.

## Fonctions

-  Dosing
-  Labelling
-  Plus/Minus Control
-  Percent Weighing
-  Totalizing
-  Parts counting
-  Peak hold
-  Formulation
-  Newton unit measurement
-  Statistics
-  Checkweighing
-  GLP Procedures
-  Animal weighing
-  Differential weighing
-  Replaceable unit
-  Statistical Quality Control
-  ALIBI Memory
-  Transactions

## Paramètres Techniques

### Paramètres métrologiques

Capacité maximale [Max]	15 kg
Capacité minimale [Min]	100 g
Précision de lecture [d]	5 g
Échelon de légalisation [e]	5 g

Paramètres métrologiques	
Étendue de tare	-15 kg
Précision de lecture maximale pour les balances non vérifiées	0,5 g
Ajustage	externe
Classe de précision OIML	III
Paramètres physiques	
Afficheur	10,1" graphique couleurs écran tactile
Longueur de câble	1 m
Dimension du plateau	300x300 mm
Dimensions de colis L x P x H	390x570x390 mm
Masse nette	10,3 kg
Masse brute	12,2 kg
Construction	
Degré de protection	IP 65 construction, IP 66 / 67 / 69 terminal
Interface de Communication	
Interface de Communication	2xRS232, 2xUSB-A, Ethernet, 4 IN / 4 OUT (numériques)
Interfaces optionnelles	module Wi-Fi 802.11 b/g/n, module Profibus (DP SLAVE), module RS485, module PROFINET (RJ45), module de sorties analogiques (4-20mA, 0-20mA, 0-10V) , 12IN / 12OUT (IN – 5-24 VDC, OUT – max 30 VDC, 0,5 ADC)
Paramètres électriques	
Alimentation	100 – 240 V AC 50/60 Hz
Conditions environnementales	
Température du travail	-10 – +40 °C
Humidité relative d'air	10% – 85% RH sans condensation

\* Wi-Fi® is a registered trademark of Wi-Fi® Alliance.



Additional fee for verification



## Accessoires (Additional Fee)

Sorties de boucle de courant AP2-4  
 Câbles RS 232 (balance – imprimante)  
 Lecteurs de cartes à transpondeur  
 Câbles RS 232 (balance – imprimante ZEBRA)  
 Câbles de réseau (balance – Ethernet)  
 Afficheurs  
 Câbles RS 232, RS 485  
 Câbles d'Entrées/ de Sorties  
 Lecteurs de code-barres  
 Imprimantes d'étiquettes

Supports, Statifs, bras-supports  
 Tables antivibratoires  
 Claviers, manipulateurs  
 Imprimante de tickets de caisse  
 Poids de classe F1 -  
 cylindrique à bouton sans cavité d'ajustage, ensembles  
 Câble USB (balance – imprimante)  
 Modules de plateforme supplémentaires  
 Modules complémentaires  
 Convertisseur RS 232 – USB

## Software (Additional Fee)

- E2R Pesages [WX-010-0099]
- Audit Trail Reader [WX-010-0186]

- RAD Key [WX-010-0005]
- Éditeur D'étiquettes R02 [WX-010-0094]

## Dimensions d'appareil L x P x H

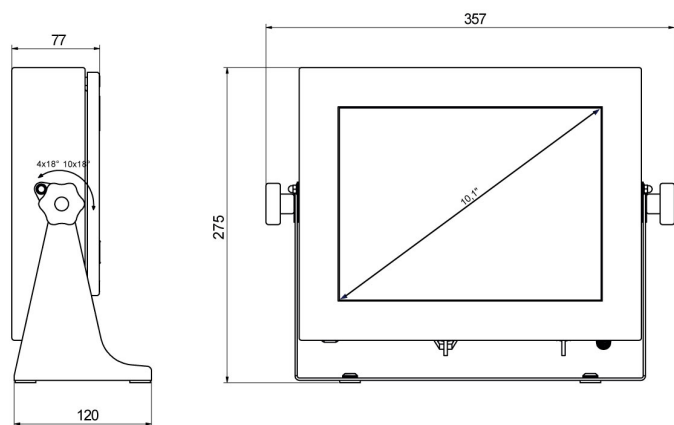

PUE HY10

Scale type	A1	A2	H
HY10.C2.K	400	500	103 ±3
HY10.C3.K	500	700	130 ±3
HY10.F1.K	300	300	70 ±3

dimensions in mm