



More information on the website  
[radwag.com/us/info,w1,QWX](http://radwag.com/us/info,w1,QWX)

# HY10.150.2.HRP.H High Resolution Scale



The drawings, photos and graphics used are for illustrative purposes only.

## Functions

-  Dosing
-  Labelling
-  Plus/Minus Control
-  Percent Weighing
-  Totalizing
-  Parts counting
-  Peak hold
-  Formulation
-  Newton unit measurement
-  Statistics
-  Checkweighing
-  GLP Procedures
-  Animal weighing
-  Differential weighing
-  Replaceable unit
-  Statistical Quality Control
-  ALIBI Memory
-  Transactions

## Datasheet

|                        |        |
|------------------------|--------|
| Maximum capacity [Max] | 150 kg |
| Minimum load           | 50 g   |
| Preload range          | 30 kg  |
| Readability [d]        | 1 g    |

|                            |   |
|----------------------------|---|
| Tare range                 | -150 kg   |
| Repeatability              | 0,6 g   |
| Linearity                  | ±3 g  |
| Stabilization time         | 3 s   |
| Adjustment                 | internal (automatic)  |
| <b>Physical parameters</b> |   |
| Display                    | 10,1" graphic colour touchscreen  |
| Weighing pan dimensions    | 500×500 mm  |
| Packaging dimensions       | 1000×800×307 mm   |
| Net weight                 | 71,5 kg   |
| Gross weight               | 119 kg  |
| <b>Construction</b>        |   |
| Protection class           | IP 66 / 67 construction, IP 68 / 69 terminal  |
| Construction               | Stainless steel AISI304   |
| Weighing pan material      | Stainless steel AISI304   |
| Communication interface    | 2×RS232, 2×USB-A, Ethernet, 4 IN / 4 OUT (digital)  |
| Optional interfaces        | module Wi-Fi 802.11 b/g/n, module Profibus (DP SLAVE), module RS485, module PROFINET (RJ45), analog output module (4-20mA, 0-20mA, 0-10V) , 12IN / 12OUT (IN – 5-24 VDC, OUT – max 30 VDC, 0,5 ADC) |
| Power supply               | 100 – 240 V AC 50/60 Hz   |
| Operating temperature      | +10 – +40 °C  |
| Relative humidity          | 15% – 80%   |

\* Wi-Fi® is a registered trademark of Wi-Fi® Alliance.



## Accessories

Transponder card readers  
 RS 232 cables (scale - ZEBRA printer)  
 RS 232 cables (scale - printer)  
 RS 232 cables (scale - Ethernet)  
 Displays  
 RS 232, RS 485 cables  
 IN/OUT Cables

Stands, wall mounting kits and mounting brackets  
 Keypad, external switches  
 Receipt Printer  
 USB cable (scale - printer)  
 Additional Weighing platforms Module  
 Additional modules

## Software

- E2R Weighing [WX-010-0099]
- E2R Weighing Records [WX-010-0038]
- Label Editor R02 [WX-010-0094]
- Scale Editor - EWAG 2.1 [WX-010-0173]

- E2R Formulations [WX-010-0043]
- Audit Trail Reader [WX-010-0186]
- RADWAG Remote Desktop [WX-010-0107]

# Device dimensions

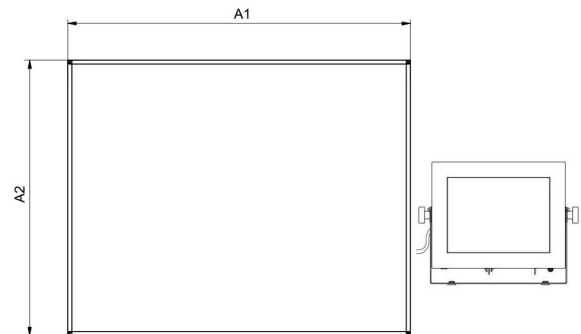
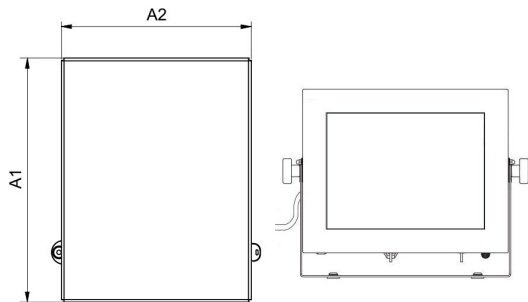
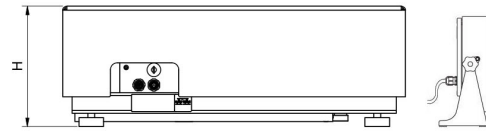
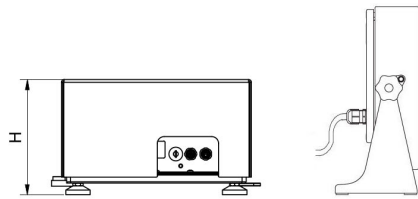

HY10.16 - 32.HRP.H

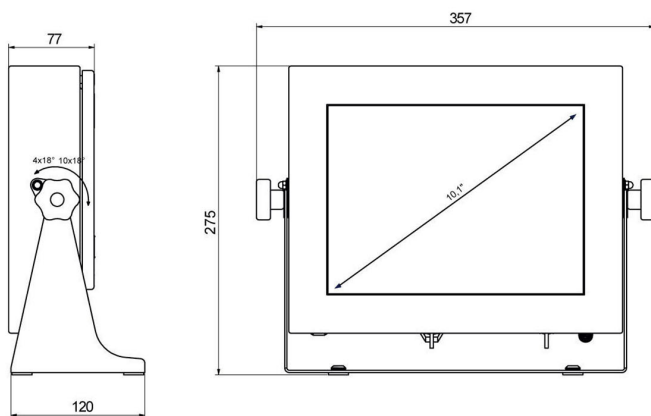

| Scale type              | A1   | A2   | H     |
|-------------------------|------|------|-------|
| HY10.(16-32).HRP.H      | 360  | 280  | 180±5 |
| HY10.(62-150).HRP.H     | 500  | 400  | 180±5 |
| HY10.150.2.HRP.H        | 500  | 500  | 180±5 |
| HY10.(150.1-300).HRP.H  | 800  | 600  | 180±5 |
| HY10.(300.1-1100).HRP.H | 1000 | 800  | 180±5 |
| HY10.(2000).HRP.H       | 1250 | 1000 | 180±5 |

Dimensions in mm

PUE HY10