



More information on the website
radwag.com/en/info,w1,QVV

PUE 5.19C Weighing Terminal



The drawings, photos and graphics used are for illustrative purposes only.

Functions



Dosing



Labelling



Plus/Minus Control



Parts counting



Formulation



Statistics



Checkweighing

Datasheet

Metrological parameters	
OIML Class	III
Maximum quantity of divisions from converter	8388608
Maximum quantity of verification units	6000 e
Minimum voltage per verification unit	0.4 μ V
Maximum voltage per verification unit	3.25 μ V
Minimum load cell impedance	80 Ω
Maximum load cell impedance	1200 Ω
Load cell excitation voltage	5V
Maximum increase of signal	19.5 mV

Metrological parameters	
Connection of load cells	4 or 6 przewodów
Physical parameters	
Display	19" graphic colour touchscreen
Device dimensions	524×420×200 mm
Packaging dimensions	590×470×240 mm
Net weight	14 kg
Gross weight	16 kg
Construction	
Protection class	IP 66 / 67 / 69
Touch panel	capacitive
Housing	Stainless steel
Communication interface	
Communication interface	4×USB 2.0 (2×USB-A, 2×M12 4P), Ethernet - 2×10/100/1000 Mbit (2×RJ45 hermetic), 2×RS232, RS485 (2×M12 8P)
Optional interfaces	external buttons PRINT, TARE, START - terminal with 4IN/4OUT (M12 8P connector) is required, additional weighing platform module - max. 3 pcs, metrological parameters as in the main weighing platform
Electrical parameters	
Power supply	100 – 240 V AC 50/60 Hz
Power consumption max.	75 W
Environmental conditions	
Operating temperature	0 – +40 °C
Storage temperature	-20 – +60 °C
Relative humidity	10% – 85% RH no condensation
Components and software	
Operating system	Microsoft Windows 11
Processor	Intel® Celeron® J6412
Chipset	Intel® UHD Graphics for 10th Gen Intel® Processors
Memory	16 GB RAM
Data memory	SSD 128 GB



Compatible with

Waterproof stainless steel platforms
Mild steel powder coated weighing platforms
Waterproof stainless steel platforms
RS 232 cables (scale - printer)
RS 232 cables (scale - ZEBRA printer)
RS 232 cables (scale - Ethernet)
Stainless steel platforms, pit version
RS 232, RS 485 cables
Mild steel powder coated weighing platforms
Ramp stainless steel platforms

IN/OUT Cables
Barcode scanners
Stainless steel ramp platforms with LD lifting system
Label Printers
Additional Weighing platforms Module
Keypad, external switches
USB adapter
F1 Mass Standard - knob weights without adjustment chamber, set
USB cable (scale - printer)
RS 232 – USB Converter

Software

- RAD Key [WX-010-0005]
- R-Lab [WX-010-0080]

- Label Editor R02 [WX-010-0094]

Device dimensions

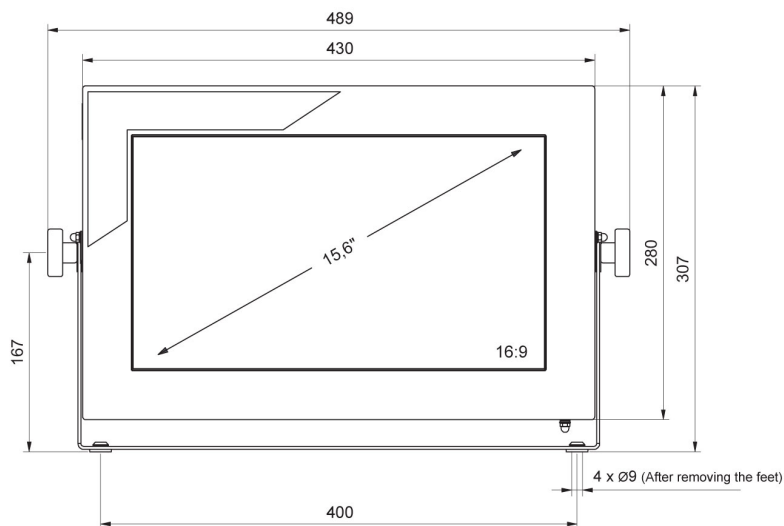
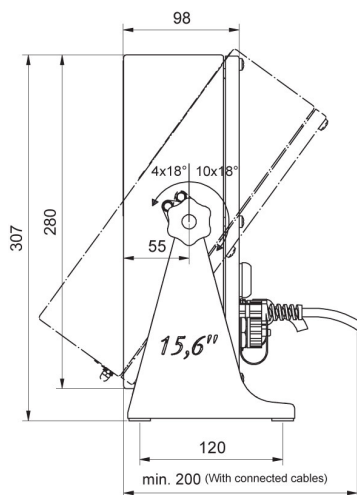

PUE 5.15

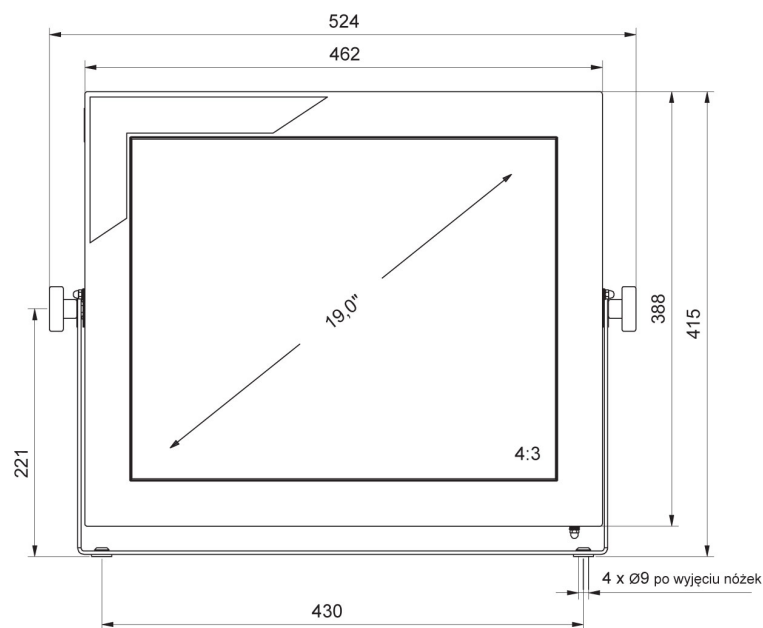
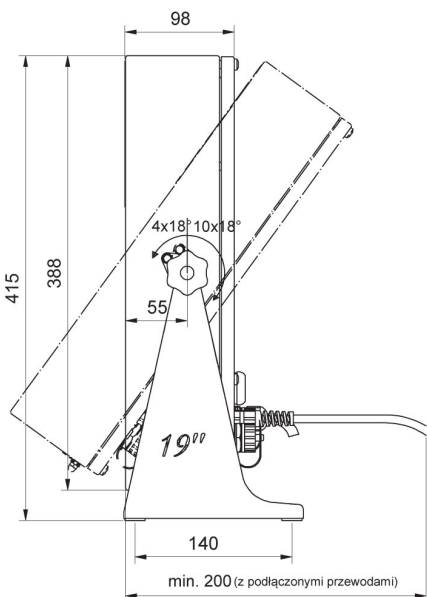

PUE 5.19