

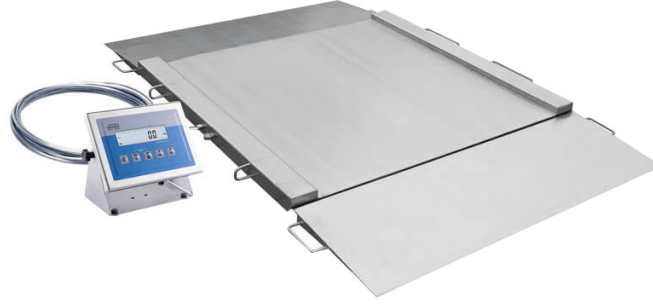

# H315.4N.1500.H2 Paslanmaz Çelik Rampalı Kantar



The drawings, photos and graphics used are for illustrative purposes only.

## Fonksiyonlar



Plus/Minus Control



Percent Weighing



Totalizing



Parts counting



Internal battery



Peak hold



Newton unit  
measurement



Animal weighing

## Teknik Veriler

Metrolojik parametreler	
Maksimum yük [Max]	1500 kg
Minimum yük [Min]	10 kg
Okuma up doğruluğu [d]	500 g
Dara aralığı	-1500 kg
Ticari amaçla kullanılmayan terazi için maksimum hassasiyet	100 g
OIML sınıfı	III
Fiziksel parametreler	
Display	LCD (backlit)
Tartım kefesi boyutları	1100×1200 mm

Fiziksel parametreler	
Ambalaj boyutları	1500×1300×600 mm
Göstergeli terazi kütlesi	190 kg
Kablo uzunluğu	3 m
Konstrüksiyon	
IP Sınıfı	IP 68 construction, IP 68 (1h max)/69 indicator
Haberleşme arayüzler	
Haberleşme arayüzü	RS232, USB
Opsiyonel arayüzler	RS232 or RS485 or 4IN/4OUT or Ethernet or analog output 4-20 mA
Elektrik parametreleri	
Güç kaynağı	100 – 240 V AC 50/60 Hz
Opsiyonel güç kaynağı	internal rechargeable battery
Batarya ile çalışma süresi	max 7h
Çevresel koşullar	
Çalıştırma sıcaklığı	-10 ÷ +40 °C
Atmosferik nem	10% ÷ 85% RH no condensation



Extra payment for verification



## Aksesuarlar

RS 232 cables (scale - printer)  
Display  
RS 232 cables (scale - Ethernet)  
RS 232, RS 485 cables  
RS 232 – Ethernet Converter  
USB adaptör

Fiş yazıcı  
USB kablo (terazi-Epson yazıcı)  
Tartım terminalleri için tutucular  
RS 232 – USB Converter  
RS 232, RS 485 Kabloları

## Yazılım

• RAD Key [WX-010-0005]  
• R-Lab [WX-010-0080]

• R Panel [WX-010-0187]  
• Terazi Editörü - EWAG 2.1 [WX-010-0173]

## Cihaz boyutları



Model	Max	A	B	C	C1	D	E	F	G	H
H315.4N.150.H1	150 kg	840	860	45,5	76	1040	1710	778	940	1170
H315.4N.300.H1	300 kg	840	860	45,5	76	1040	1710	778	940	1170
H315.4N.600.H1	600 kg	840	860	45,5	76	1040	1710	778	940	1170
H315.4N.150.H2	1500 kg	1100	1200	45,5	76	1300	2050	1118	1200	1430
H315.4N.300.H2	300 kg	1100	1200	45,5	76	1300	2050	1118	1200	1430
H315.4N.600.H2	600 kg	1100	1200	45,5	76	1300	2050	1118	1200	1430
H315.4N.1500.H2	1500 kg	1100	1200	52,5	76	1300	2150	1118	1200	1430
H315.4N.300.H3	300 kg	1200	1500	45,5	76	1400	2350	1418	1300	1530
H315.4N.600.H3	600 kg	1200	1500	45,5	76	1400	2350	1418	1300	1530
H315.4N.1500.H3	1500 kg	1200	1500	52,5	76	1400	2450	1418	1300	1530
H315.4N.300.H4	300 kg	1500	1500	52,5	76	1700	2450	1418	1600	1830
H315.4N.600.H4	600 kg	1500	1500	52,5	76	1700	2450	1418	1600	1830
H315.4N.1500.H4	1500 kg	1500	1500	52,5	76	1700	2450	1418	1600	1830