



More information on the website
radwag.com/us/info,w1,N7Z

AS 520.R2 PLUS Analytical Balance



The drawings, photos and graphics used are for illustrative purposes only.

Functions



Autotest



Dosing



Percent Weighing



Totalizing



Parts counting



Peak hold



Newton unit measurement



Statistics



Checkweighing



Under-pan weighing



GLP Procedures



Animal weighing



Density determination

Datasheet

Maximum capacity [Max]	520 g
Minimum load	-
Readability [d]	0,1 mg
Verification unit [e]	-
Tare range	-520 g
Standard repeatability [5% Max]	0,08 mg

Standard repeatability [Max]	0,25 mg
Standard minimum weight (USP)	160 mg
Standard minimum weight (U=1%, k=2)	16 mg
Permissible repeatability [5% Max]	0,12 mg
Permissible repeatability [Max]	0,4 mg
Linearity	±0,6 mg
Stabilization time	2,5 s
Adjustment	internal (automatic)
OIML Class	-
Physical parameters	
Leveling system	manual
Display	LCD (backlit)
Weighing chamber doors	manual
Delivery components	Balance, weighing pan, weighing pan shield, bottom cover, power supply.
Weighing pan dimensions	ø100 mm
Packaging dimensions	490×400×520 mm
Net weight	7,3 kg
Gross weight	8,5 kg
Construction	
Protection class	IP 43
Communication interface	2×RS232 ¹ , 2×USB-A (interchangeable), USB-B, Wi-Fi (option)
Power supply	Adapter: 100 – 240V AC 50/60Hz 0,6A; 12V DC 1,2A Balance: 12 – 15V DC 0,4A max
Power consumption max.	3 W
Operating temperature	+10 – +40 °C
Relative humidity	40% – 80%

Repeatability is expressed as a standard deviation from 10 weighing cycles.

Stabilization time depends on the ambient conditions and the dynamics of weighing pan loading; specified for FAST profile.

¹ Barcode scanners, available as weighing instrument accessory, communicate with the instrument via RS232 interface exclusively.

* Wi-Fi® is a registered trademark of Wi-Fi® Alliance.



Accessories

Antivibration tables
 Holders for laboratory flasks
 Power Adapters
 Cigarette lighter receptacle power supply cables
 Density determination KIT
 USB cable (scale - printer)

RS 232, RS 485 cables
 Displays
 Protective cover for balances
 Weighing dishes
 Antistatic ionizer
 Receipt Printer

Professional Weighing Tables
Barcode scanners
Holders for test tubes and filters
Workstation for pipettes calibration

RS 232, RS 485 cables
Under-pan weighing
RS 232 cables (scale - printer)

Software

- RAD Key [WX-010-0005]
- Alibi Reader PC Software [WX-010-0114]

- R Panel [WX-010-0187]
- RADWAG Development Studio [WX-010-0104]

Device dimensions

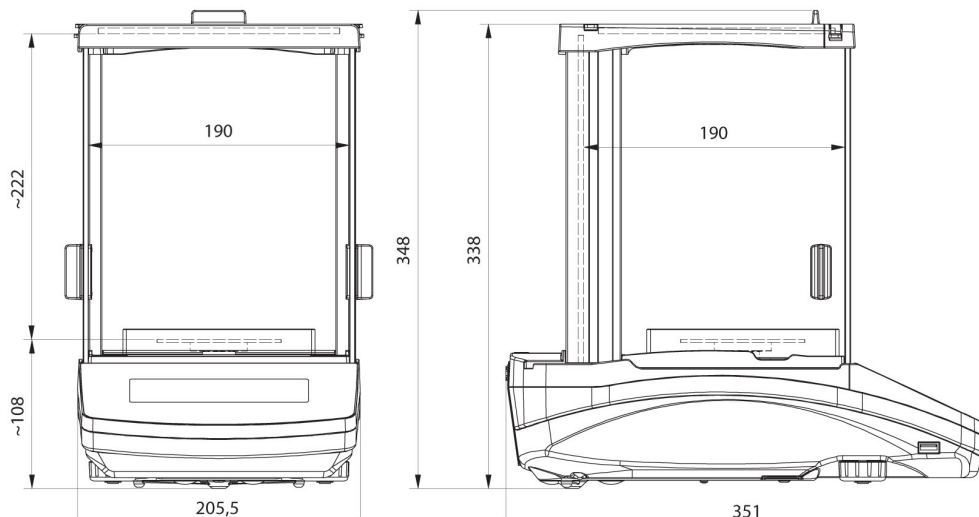

AS R2, d = 0.01 mg

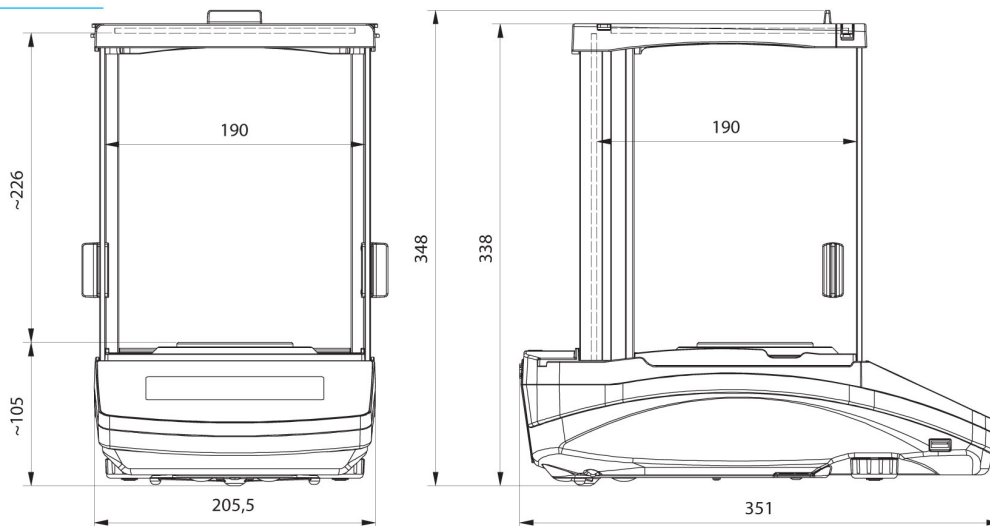

AS R2, AS R1 d = 0.1 mg