



More information on the website
radwag.com/fr/info,w1,MJT

Balance de précision PS 360.R1



The drawings, photos and graphics used are for illustrative purposes only.

Fonctions

-  Autotest
-  Dosing
-  Percent Weighing
-  Totalizing
-  Parts counting
-  Peak hold
-  Newton unit measurement
-  Statistics
-  Checkweighing
-  Under-pan weighing
-  GLP Procedures
-  Animal weighing
-  Density determination

Paramètres Techniques

Paramètres métrologiques	
Capacité maximale [Max]	360 g
Capacité minimale [Min]	20 mg
Précision de lecture	0,001 g
Étendue de tare	-360 g
Répétabilité (Max)	0,001 g
Répétabilité (5% Max)	0,0005 g

Paramètres métrologiques	
Linéarité	±0,002 g
Temps de stabilisation	2 s
Ajustage	externe
Dérive de température de la sensibilité	$2 \times 10^{-6} / ^\circ\text{C} \times \text{Rt}$
Paramètres physiques	
Système de nivellement	manuel
Afficheur	LCD (rétro-éclairé)
Élément du kit	Balance, plateau, couvercle de plateau, vis de mise à la terre ×1, vis ×3, adaptateur secteur.
Dimension du plateau	128×128 mm
Dimensions de colis	475×380×345 mm
Masse nette	3,2 kg
Masse brute	5 kg
Construction	
Degré de protection	IP 43
Interface de Communication	
Interface de Communication	2×RS232, USB-A, USB-B, Wi-Fi (option)
Paramètres électriques	
Alimentation	Adapter: 100 – 240V AC 50/60Hz 0,6A; 12V DC 1,2A Balance: 12 – 15V DC 0,4A max
Prise d'alimentation par l'appareil	4 W
Conditions environnementales	
Température du travail	+10 – +40 °C
Humidité relative d'air	40% – 80%

Répétabilité exprimée comme un écart standardisé de 10 placements de chargé.

Temps de stabilisation dépend de conditions externes et de la dynamique du placement d'un poids sur le plateau; déterminé pour le profil FAST

¹ Les scanners de codes-barres disponibles en accessoire coopèrent avec la balance en utilisant uniquement l'interface RS232.

* Wi-Fi® is a registered trademark of Wi-Fi® Alliance.



Accessoires

Valises pour balances
Tables antivibratoires
Alimentateurs
Câbles d'alimentation de cigare-allume
Câble USB (balance – imprimante)
KIT pour déterminer la densité
Lecteurs de code-barres
Boîte pour balances avec le plateau 128×128mm

Câbles RS 232, RS 485
Afficheurs
Piège anti-courant d'air
Imprimante de tickets de caisse
Écran de protection anti-poussière
Câbles RS 232, RS 485
Pesage sous la balance
Câbles RS 232 (balance – imprimante)

Software

- RAD Key [WX-010-0005]
- Alibi Reader [WX-010-0114]
- RADWAG Studio du Développement [WX-010-0104]

- R Panel [WX-010-0187]
- R-LAB [WX-010-0080]

Dimensions d'appareil

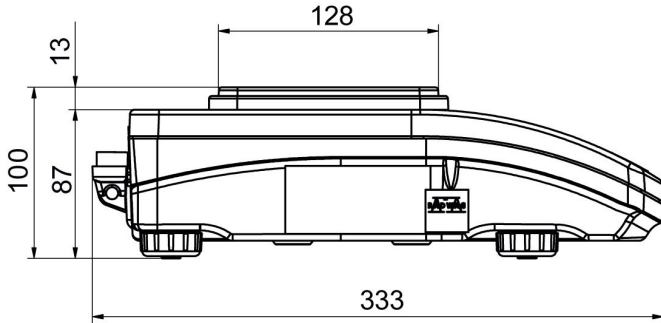

PS R, d = 1 mg

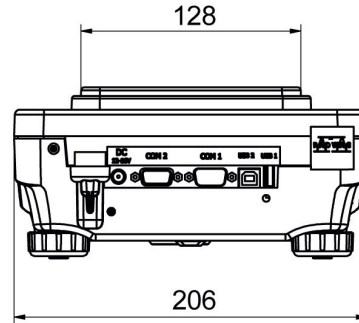

PS R, d = 10 mg

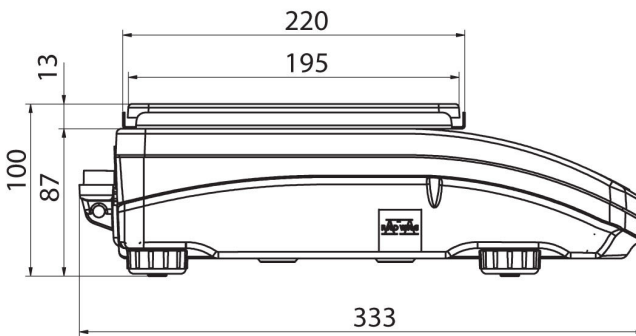
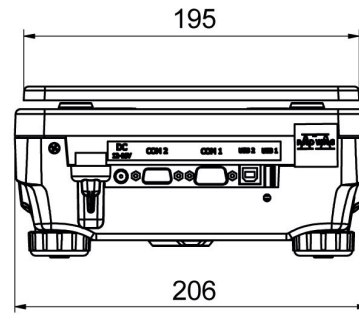

PS R.M, d = 10 mg

