



More information on the website
radwag.com/us/info,w1,LZY

AS 220.R1 PLUS Analytical Balance



The drawings, photos and graphics used are for illustrative purposes only.

Functions



Autotest



Dosing



Percent Weighing



Totalizing



Parts counting



Peak hold



Newton unit measurement



Statistics



Checkweighing



Under-pan weighing



GLP Procedures



Animal weighing



Density determination

Datasheet

Maximum capacity [Max]	220 g
Minimum load	10 mg
Readability [d]	0,1 mg
Tare range	-220 g
Standard repeatability [5% Max]	0,07 mg
Standard repeatability [Max]	0,08 mg

Standard minimum weight (USP)	140 mg
Standard minimum weight (U=1%, k=2)	14 mg
Permissible repeatability [5% Max]	0,09 mg
Permissible repeatability [Max]	0,1 mg
Linearity	±0,2 mg
Stabilization time	2 s
Adjustment	external
OIML Class	-
Physical parameters	
Leveling system	manual
Display	LCD (backlit)
Weighing chamber doors	manual
Delivery components	Balance, weighing pan, weighing pan shield, bottom cover, power supply.
Weighing pan dimensions	ø100 mm
Packaging dimensions	490×400×520 mm
Net weight	7,3 kg
Gross weight	9,3 kg
Construction	
Protection class	IP 43
Communication interface	2×RS232, 2×USB-A (interchangeable), USB-B, Wi-Fi (option)
Power supply	Adapter: 100 – 240V AC 50/60Hz 0,6A; 12V DC 1,2A Balance: 12 – 15V DC 0,4A max
Operating temperature	+10 – +40 °C
Relative humidity	40% – 80%

Repeatability is expressed as a standard deviation from 10 weighing cycles.

Stabilization time depends on the ambient conditions and the dynamics of weighing pan loading; specified for FAST profile.

* Wi-Fi® is a registered trademark of Wi-Fi® Alliance.



Accessories

Holders for laboratory flasks
 Power Adapters
 Cigarette lighter receptacle power supply cables
 Density determination KIT
 USB cable (scale - printer)
 Professional Weighing Tables
 Barcode scanners
 Holders for test tubes and filters
 Workstation for pipettes calibration
 RS 232, RS 485 cables

Antivibration tables
 Displays
 Weighing dishes
 Antistatic ionizer
 Receipt Printer
 AP2-1 Current Loop Unit
 RS 232, RS 485 cables
 Under-pan weighing
 RS 232 cables (scale - printer)

Software

- RAD Key [WX-010-0005]
- Alibi Reader PC Software [WX-010-0114]

- R Panel [WX-010-0187]
- RADWAG Development Studio [WX-010-0104]

Device dimensions

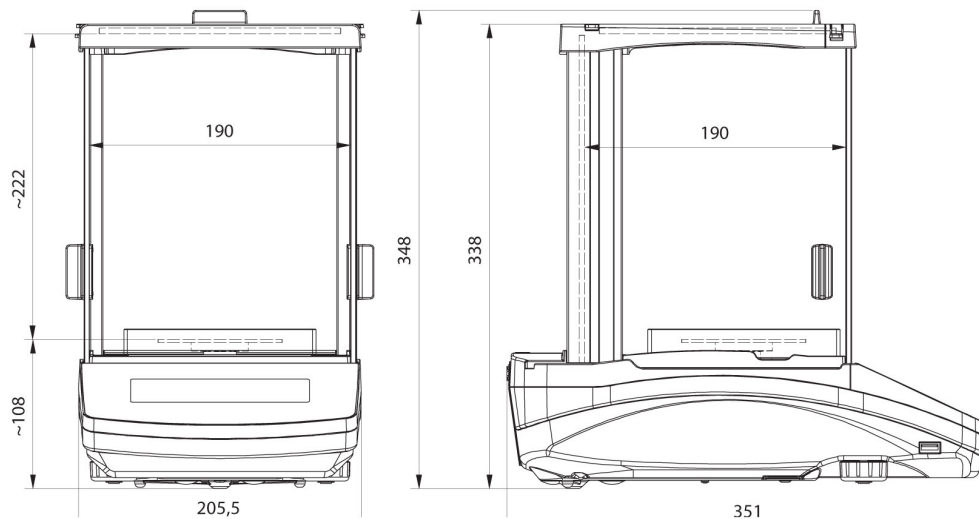

AS R2, d = 0.01 mg

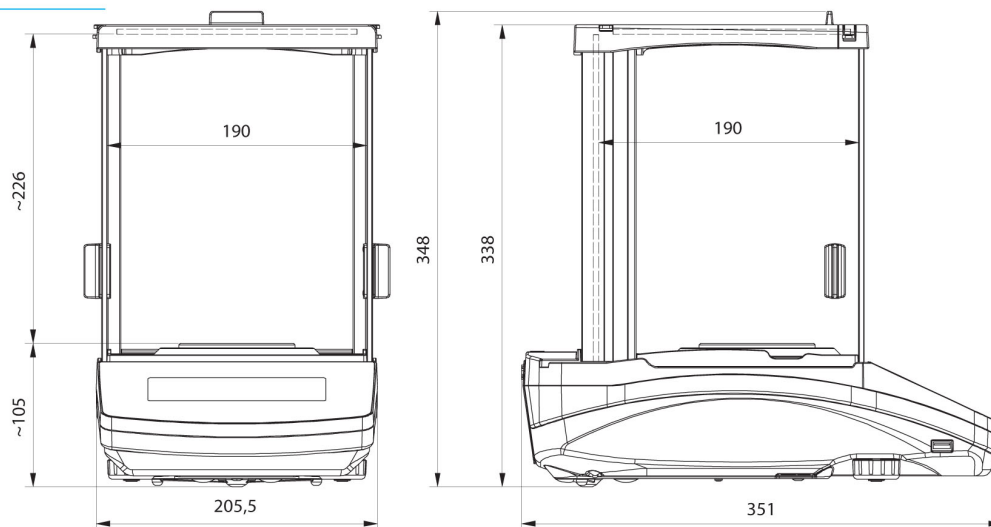

AS R2, AS R1 d = 0.1 mg