



More information on the website
radwag.com/de/info,w1,LRI

Präzisionswaage PS 4500.R2.M



The drawings, photos and graphics used are for illustrative purposes only.

Funktionen



Autotest



Dosing



Percent Weighing



Totalizing



Parts counting



Peak hold



Newton unit measurement



Statistics



Checkweighing



GLP Procedures



Animal weighing



Density determination

Technische Daten

Messtechnische Parameter	
Wägebereich [Max]	4500 g
Min. Belastung	500 mg
Zifferschritt [d]	10 mg
Eichwert [e]	100 mg
Tarierbereich	-4500 g
Standard Wiederholbarkeit [5% Max]	5 mg
Standard Wiederholbarkeit [Max]	8 mg

Messtechnische Parameter	
Min. Einwaage (USP)	10 g
Min. Einwaage (U=1%, k=2)	1 g
Linearität	±20 mg
Stabilisierungszeit	1,5 s
Justierung	intern (automatisch)
OIML-Klasse	II
Empfindlichkeitsdrift Temperatur	$2 \times 10^{-6} / ^\circ\text{C} \times \text{Rt}$
Physikalische Parameter	
Nivelliersystem	manualny
Display	LCD (hinterleuchtet)
Lieferumfang	Waage, Waagschale, Waagschalenabdeckung, Netzteil
Waagschale	195×195 mm
Abmessungen des Geräts	333×206×107 mm
Verpackungsgröße	475×380×345 mm
Nettogewicht	4,26 kg
Bruttogewicht	5,5 kg
Konstruktion	
Schutzart	IP 43
Kommunikationsschnittstellen	
Schnittstellen	2×RS232 ¹ , USB-A, USB-B, Wi-Fi (optional)
Elektrische Parameter	
Stromversorgung	Adapter: 100 – 240V AC 50/60Hz 0,6A; 12V DC 1,2A Waage: 12 – 15V DC 0,4A max
Leistungsaufnahme des Geräts	4 W
Umgebungsbedingungen	
Umgebungstemperatur	+10 ÷ +40 °C
Lagertemperatur	-20 ÷ +50 °C
Relative Luftfeuchtigkeit	40% ÷ 80%

Wiederholbarkeit wird als Standardabweichung von 10 Wägezyklen ausgedrückt.

Die Stabilisierungszeit ist abhängig von den Umgebungsbedingungen und der Geschwindigkeit bei Auflegen der Last auf der Waagschale; für FAST-Profil definiert.

¹ Barcode scanners, available as weighing instrument accessory, communicate with the instrument via RS232 interface exclusively.

* Wi-Fi® is a registered trademark of Wi-Fi® Alliance.



Extra payment for verification



Zubehör

Waagenkoffer
Antivibrationstische
Netzteile
Anschlusskabel für Zigarettanzünder

Displays
Dichtebestimmungsset
Schutzhauben
Thermische Drucker

USB-Kabel (Waage – Drucker)
Barcodescanner
Kabel RS 232, RS 485

Kabel RS 232, RS 485
Unterflurwägung
Kabel RS 232 (Waage – Drucker)

Software

- RAD Key [WX-010-0005]
- Alibi Reader [WX-010-0114]
- RADWAG Development Studio [WX-010-0104]

- R Panel [WX-010-0187]
- RLAB [WX-010-0080]

Abmessungen des Geräts

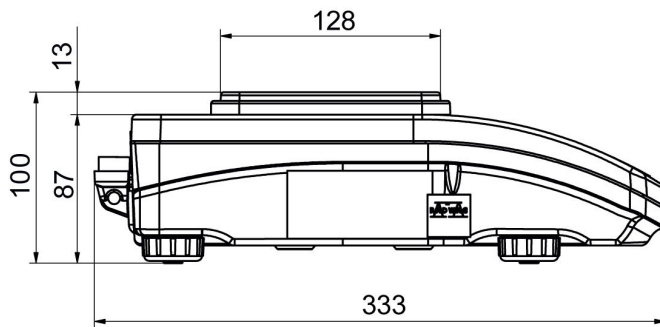

PS R, d = 1mg

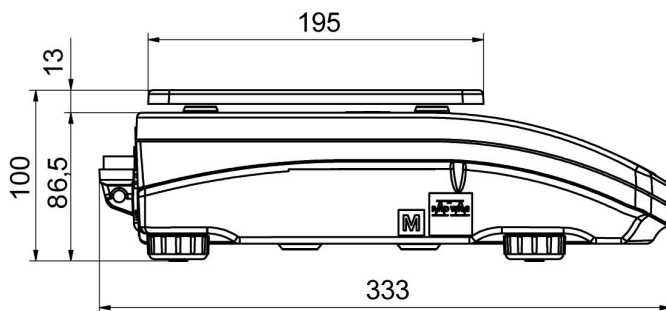
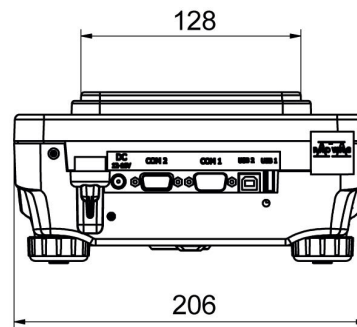

PS R, d = 10 mg

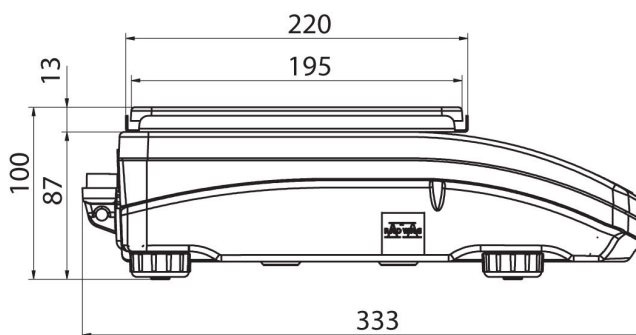
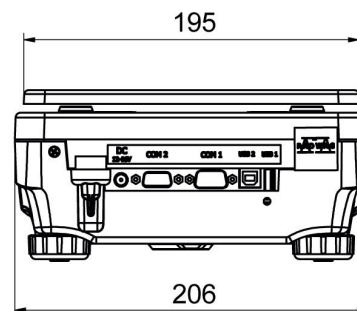

PS R.M, d = 10 mg

