



More information on the website
radwag.com/tr/info,w1,K13

MAS.1.82/220 Tartım Modülü



The drawings, photos and graphics used are for illustrative purposes only.

Teknik Veriler

Metrolojik parametreler	
Maksimum yük [Max]	82 / 220 g
Minimum yük [Min]	1 mg
Ön yük	8,2 g
Okuma up doğruluğu [d]	0,01 / 0,1 mg
Dara aralığı	-220 g
Minimum ağırlık (USP)	40 mg
Minimum ağırlık (U=1%,k=2)	4 mg
Tekrarlanabilirlik (Max)	0,1 mg
Düşük yükte tekrarlanabilirlik	0,02 mg
Doğrusallık	±0,06 / 0,2 mg
Kararlılık süresi	6 / 2 s
Konstrüksiyon	
IP Sınıfı	IP 54

Haberleşme arayüzler	
Haberleşme arayüzü	RS232
Elektrik parametreleri	
Güç kaynağı	100 – 240 V AC 50/60 Hz
Çevresel koşullar	
Çalıştırma sıcaklığı	+10 ÷ +40 °C
Atmosferik nem	40% ÷ 80%
Fiziksel parametreler	
Tartım kefesi boyutları	ø42 mm
Cihaz boyutları	289×143×125 mm
Ambalaj boyutları	650×340×315 mm
Net ağırlık	4,1 kg
Brüt ağırlık	6,1 kg



Aksesuarlar

Antivibrasyon masaları
RS 232, RS 485 cables
Profesyonel tartım masaları

RS 232 – USB Converter
RS 232, RS 485 Kabloları

Yazılım

• RAD Key [WX-010-0005]
• R-Lab [WX-010-0080]

• R Panel [WX-010-0187]
• RADWAG Development Studio [WX-010-0104]

Cihaz boyutları



MAS.1
MAS.1.R



MAS.1



MAS.1.Y

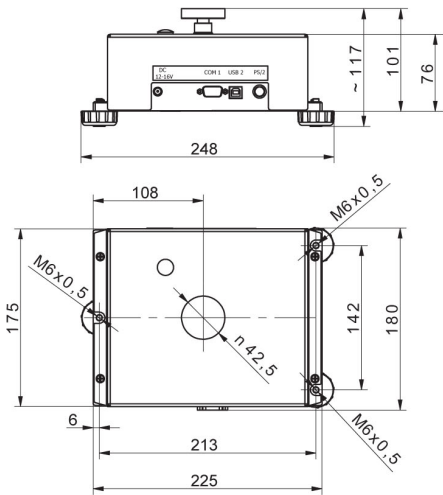

MAS



R operator panel



Y operator panel