



More information on the website
radwag.com/it/info,w1,KI3

MAS.1.82/220 Modulo di pesatura



The drawings, photos and graphics used are for illustrative purposes only.

Specifiche

Parametri metrologici	
Portata massima [Max]	82 / 220 g
Portata minima [Min]	1 mg
Intervallo di precarico	8,2 g
Divisione [d]	0,01 / 0,1 mg
Campo di tara	-220 g
Portata minima (secondo USP)	40 mg
Portata minima (U=1%,k=2)	4 mg
Ripetibilita (Max)	0,1 mg
Ripetibilita (5% Max)	0,02 mg
Linearità	±0,06 / 0,2 mg
Tempo di stabilizzazione	6 / 2 s
Costruzione	
Punteggio IP	IP 54

Interfaccia di comunicazione	
Interfaccia	RS232
Parametri elettrici	
Alimentatore	100 – 240 V AC 50/60 Hz
Environmental conditions	
Ambiente di lavoro	+10 – +40 °C
Umidità relativa	40% – 80%
Parametri fisici	
Dimensione piatto	ø42 mm
Device dimensions	289×143×125 mm
Dimensioni del pacco	650×340×315 mm
Peso netto	4,1 kg
Peso lordo	6,1 kg



Accessori

Tavoli antivibranti
 Cavo seriale RS 232, RS 485
 Tavolo di pesata professionale

RS 232 – USB Converter
 Cavo seriale RS 232, RS 485

Software

- RAD Key [WX-010-0005]
- R-LAB [WX-010-0080]

- R Panel [WX-010-0187]
- Software „Development Studio“ RADWAG [WX-010-0104]

Device dimensions

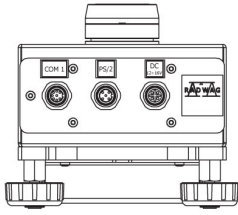

MAS.1
MAS.1.R

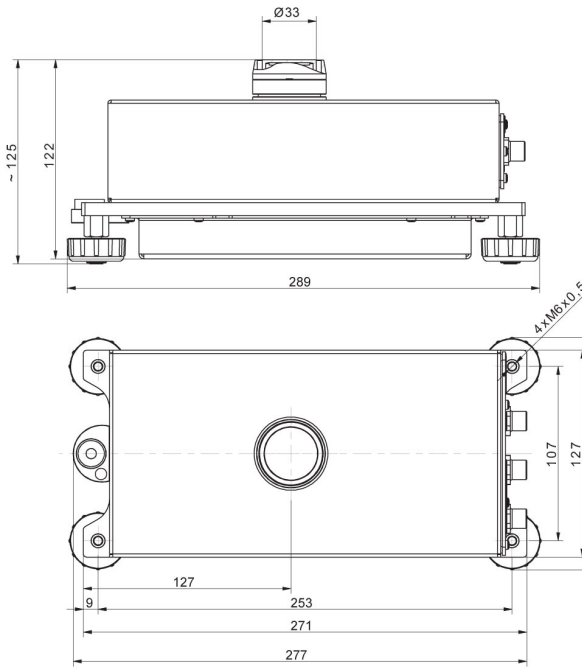

MAS.1

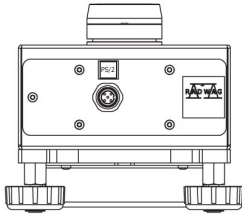

MAS.1.Y

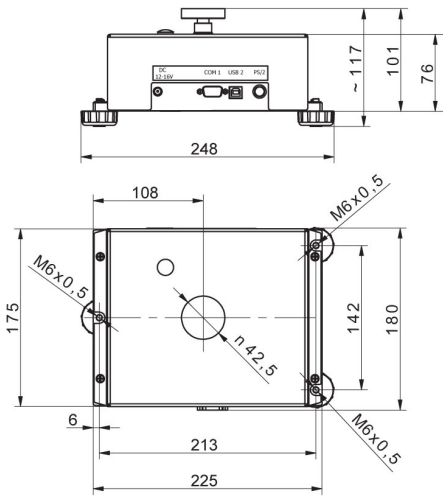

MAS

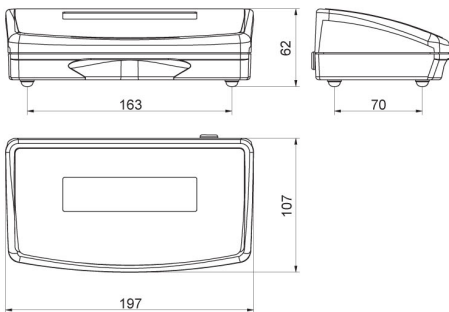

R operator panel

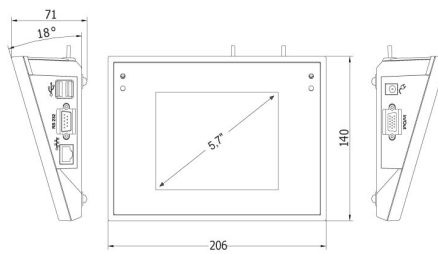

Y operator panel