



More information on the website
radwag.com/us/info,w1,K57

MPS 6000.Y Weighing Module



The drawings, photos and graphics used are for illustrative purposes only.

Datasheet

Maximum capacity [Max]	6000 g
Readability [d]	10 mg
Tare range	-6000 g
Physical parameters	
Display	5,7" Resistiv-Farb-Touchscreen
Weighing pan dimensions	ø115 mm
Device dimensions	293×190×112 mm
Packaging dimensions	515×340×295 mm
Net weight	4,8 kg
Power supply	100 – 240 V AC 50/60 Hz
Operating temperature	+15 ÷ +35 °C
Relative humidity	40% ÷ 80%



Accessories

Antivibration tables
Professional Weighing Tables
RS 232, RS 485 cables

RS 232 – USB Converter
RS 232 cables (scale - printer)

Software

• RAD Key [WX-010-0005]
• RADWAG Development Studio [WX-010-0104]

• R Panel [WX-010-0187]

Device dimensions

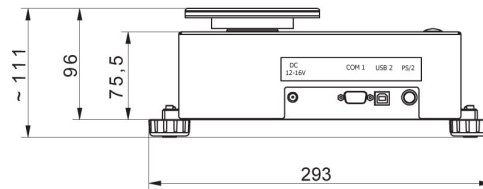
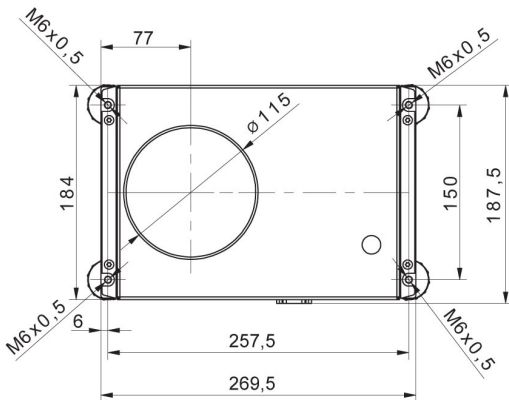

MPS

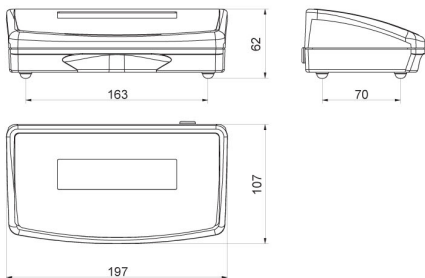

R operator panel

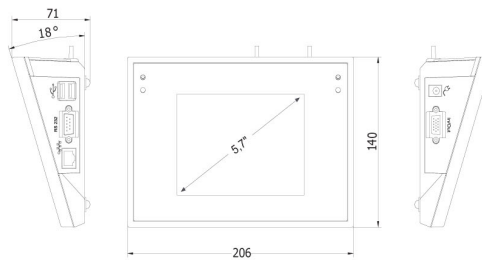

Y operator panel