



More information on the website
radwag.com/es/info,w1,K57

Módulo de pesaje MPS 6000.Y



The drawings, photos and graphics used are for illustrative purposes only.

Datos técnicos

Parámetros metrológicos	
Maxima capacidad [Max]	6000 g
Legibilidad [d]	10 mg
Rango de tara	-6000 g
Parámetros físicos	
Pantalla	5,7" Pantalla táctil resistiva en color
Dimensión de platillo	ø115 mm
Dimensiones de aparato	293×190×112 mm
Dimensiones de embalaje	515×340×295 mm
Masa neta	4,8 kg
Parámetros electricos	
Alimentacion	100 – 240 V AC 50/60 Hz
Condiciones ambientales	
Temperatura de trabajo	+15 – +35 °C
Humedad relativa de aire	40% – 80%



Accesorios

Mesas antivibratil
 Mesas de pesaje profesional
 Cables RS 232, RS 485

Convertidor RS 232 a USB
 Cables RS 232 (Bascula a Impresora)

Programas

- RAD Key [WX-010-0005]
- R-LAB [WX-010-0080]

- R Panel [WX-010-0187]
- RADWAG Development Studio [WX-010-0104]

Dimensiones de aparato

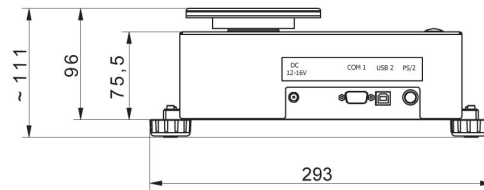
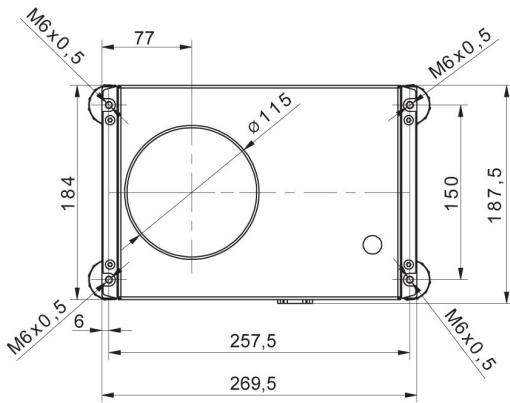

MPS

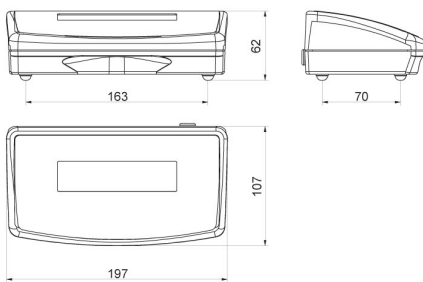

R operator panel

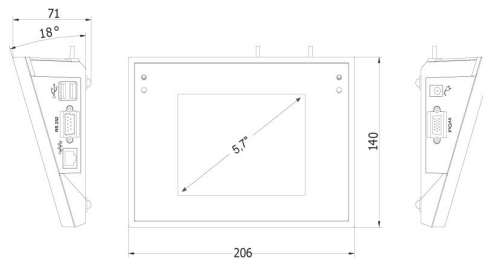

Y operator panel