



More information on the website
radwag.com/en/info,w1,J16

WLC 1/A2/C/2/IO Precision Balance



The drawings, photos and graphics used are for illustrative purposes only.

Functions

 Plus/Minus Control

 Percent Weighing

 Totalizing

 Parts counting

 Internal battery

 Peak hold

 Newton unit measurement

Datasheet

Metrological parameters	
Maximum capacity [Max]	1 kg
Readability [d]	0.01 g
Verification unit [e]	-
Tare range	-1 kg
Repeatability	0.015 g
Linearity	±0.03 g
Stabilization time	3 s
Adjustment	internal (automatic)

Physical parameters	
Leveling system	manualny
Display	LCD (backlit)
Weighing pan dimensions	195×195 mm
Packaging dimensions	430×270×190 mm
Net weight	3.6 kg
Gross weight	5 kg
Construction	
Protection class	IP 43
Communication interface	
Communication interface	2×RS232, USB-A, USB-B, 4 IN / 4 OUT
Electrical parameters	
Power supply	Adapter: 100 – 240V AC 50/60Hz 0.6A; 12V DC 1.2A Balance: 10 – 15VDC 0.6A max
Operation time on batteries	15 h (average time)
Environmental conditions	
Operating temperature	+15 ÷ +30 °C
Relative humidity	10% ÷ 85% RH no condensation

Repeatability is expressed as a standard deviation from 10 weighing cycles.

Stabilization time depends on the ambient conditions and the dynamics of weighing pan loading; specified for FAST profile.



Accessories

Balance Storage Case
 Antivibration Tables
 Power Adapters
 RS 232 cables (scale - printer)
 Cigarette lighter receptacle power supply cables
 Under-pan weighing
 RS 232, RS 485 cables
 Density determination KIT

RS 232 – Ethernet Converter
 Displays
 Receipt Printer
 AP2-1 Current Loop Unit
 RS 232, RS 485 cables
 Protective cover for balances
 RS 232 cables (scale - printer)
 RS 232 – RS 485 Converter

Software

- RAD Key [WX-010-0005]
- R-Lab [WX-010-0080]

- Alibi Reader [WX-010-0114]
- Scale Editor 2.1 [WX-010-0173]

Device dimensions

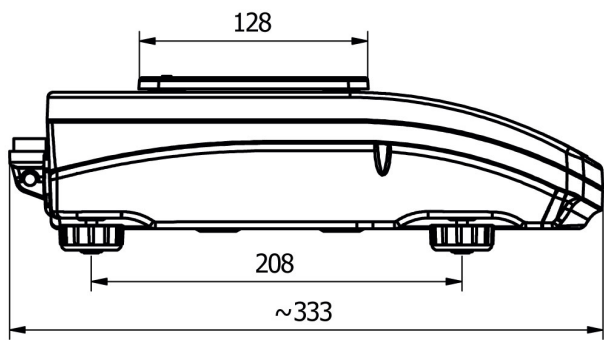

WLC A1

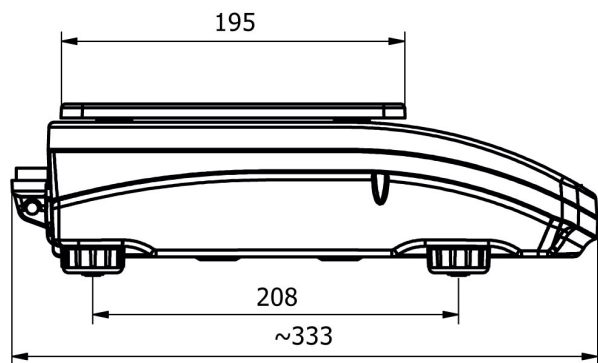

WLC A2

