



More information on the website
radwag.com/en/info,w1,HRY

PS 600.R2.1 Precision Balance



The drawings, photos and graphics used are for illustrative purposes only.

Functions



Autotest



Dosing



Percent Weighing



Totalizing



Parts counting



Peak hold



Newton unit measurement



Statistics



Checkweighing



GLP Procedures



Animal weighing



Density determination

Datasheet

Metrological parameters	
Maximum capacity [Max]	600 g
Minimum load	500 mg
Readability [d]	10 mg
Verification unit [e]	10 mg
Tare range	-600 g
Standard repeatability [5% Max]	5 mg
Standard repeatability [Max]	10 mg

Metrological parameters	
Standard minimum weight (USP)	1 g
Standard minimum weight (U=1%, k=2)	0.1 g
Linearity	±20 mg
Stabilization time	1.5 s
Adjustment	internal (automatic)
OIML Class	II
Sensitivity temperature drift	$2 \times 10^{-6} / ^\circ\text{C} \times \text{Rt}$
Physical parameters	
Leveling system	manualny
Display	LCD (backlit)
Delivery components	Balance, weighing pan, grounding bumper ×1, bumper ×3, power supply.
Weighing pan dimensions	195×195 mm
Packaging dimensions	475×380×345 mm
Net weight	3.9 kg
Gross weight	5.5 kg
Construction	
Protection class	IP 43
Communication interface	
Communication interface	2×RS232 ¹ , USB-A, USB-B, Wi-Fi (option)
Electrical parameters	
Power supply	Adapter: 100 – 240V AC 50/60Hz 0.6A; 12V DC 1.2A Balance: 12 – 15V DC 0.4A max
Power consumption	4 W
Environmental conditions	
Operating temperature	+10 ÷ +40 °C
Relative humidity	40% ÷ 80%

Repeatability is expressed as a standard deviation from 10 weighing cycles.

Stabilization time depends on the ambient conditions and the dynamics of weighing pan loading; specified for FAST profile.

¹ Barcode scanners, available as weighing instrument accessory, communicate with the instrument via RS232 interface exclusively.

* Wi-Fi® is a registered trademark of Wi-Fi® Alliance.



Extra payment for verification



Accessories

Balance Storage Case
Antivibration Tables
Power Adapters
Cigarette lighter receptacle power supply cables
USB cable (scale - printer)
Barcode scanners
RS 232, RS 485 cables

Density determination KIT
Displays
Receipt Printer
RS 232, RS 485 cables
Protective cover for balances
Under-pan weighing
RS 232 cables (scale - printer)

Software

- RAD Key [WX-010-0005]
- Alibi Reader [WX-010-0114]
- RADWAG Development Studio [WX-010-0104]
- R-Panel [WX-010-0187]
- R-Lab [WX-010-0080]

Device dimensions

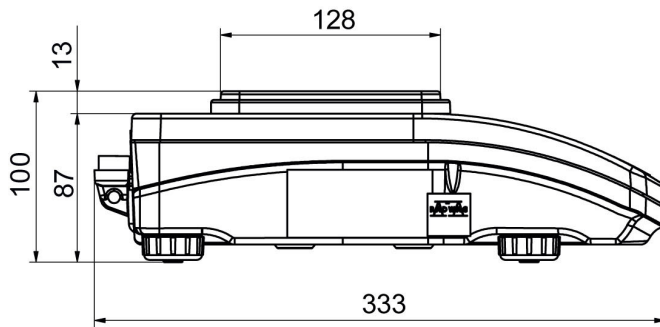

PS R, d = 1mg

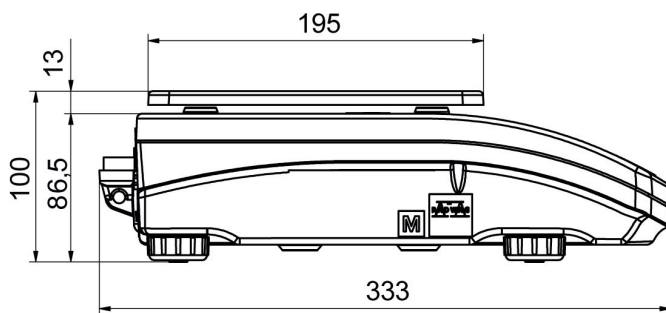

PS R, d = 10 mg

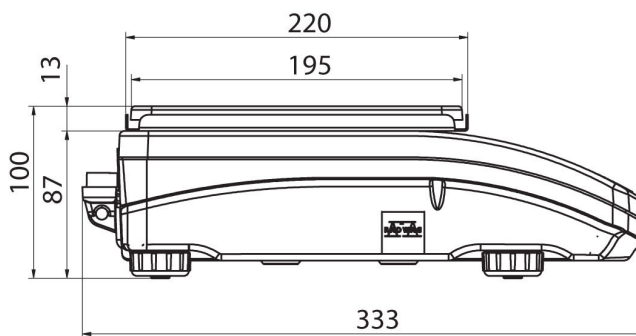
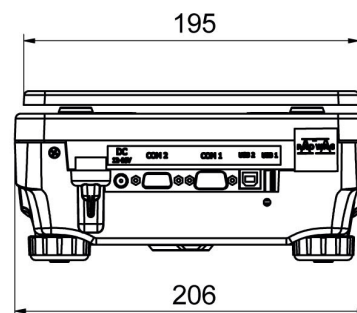

PS R.M, d = 10 mg

