



More information on the website
radwag.com/en/info,w1,HRY

PS 600.R2.1 Precision Balance



The drawings, photos and graphics used are for illustrative purposes only.

Functions



Autotest



Dosing



Percent Weighing



Totalizing



Parts counting



Peak hold



Newton unit measurement



Statistics



Checkweighing



GLP Procedures



Animal weighing



Density determination

Datasheet

| Metrological parameters | |
|---------------------------------|--------|
| Maximum capacity [Max] | 600 g |
| Minimum load | 500 mg |
| Readability [d] | 10 mg |
| Verification unit [e] | 10 mg |
| Tare range | -600 g |
| Standard repeatability [5% Max] | 5 mg |
| Standard repeatability [Max] | 10 mg |

| Metrological parameters | |
|-------------------------------------|---|
| Standard minimum weight (USP) | 1 g |
| Standard minimum weight (U=1%, k=2) | 0.1 g |
| Linearity | ±20 mg |
| Stabilization time | 1.5 s |
| Adjustment | internal (automatic) |
| OIML Class | II |
| Sensitivity temperature drift | $2 \times 10^{-6} / ^\circ\text{C} \times \text{Rt}$ |
| Physical parameters | |
| Leveling system | manualny |
| Display | LCD (backlit) |
| Delivery components | Balance, weighing pan, grounding bumper ×1, bumper ×3, power supply. |
| Weighing pan dimensions | 195×195 mm |
| Packaging dimensions | 475×380×345 mm |
| Net weight | 3.9 kg |
| Gross weight | 5.5 kg |
| Construction | |
| Protection class | IP 43 |
| Communication interface | |
| Communication interface | 2×RS232 ¹ , USB-A, USB-B, Wi-Fi (option) |
| Electrical parameters | |
| Power supply | Adapter: 100 – 240V AC 50/60Hz 0.6A; 12V DC 1.2A Balance: 12 – 15V DC 0.4A max |
| Power consumption | 4 W |
| Environmental conditions | |
| Operating temperature | +10 ÷ +40 °C |
| Relative humidity | 40% ÷ 80% |

Repeatability is expressed as a standard deviation from 10 weighing cycles.

Stabilization time depends on the ambient conditions and the dynamics of weighing pan loading; specified for FAST profile.

¹ Barcode scanners, available as weighing instrument accessory, communicate with the instrument via RS232 interface exclusively.

* Wi-Fi® is a registered trademark of Wi-Fi® Alliance.



Extra payment for verification



Accessories

Balance Storage Case
 Antivibration Tables
 Power Adapters
 Cigarette lighter receptacle power supply cables
 USB cable (scale - printer)
 Barcode scanners
 RS 232, RS 485 cables

Density determination KIT
 Displays
 Receipt Printer
 RS 232, RS 485 cables
 Protective cover for balances
 Under-pan weighing
 RS 232 cables (scale - printer)

Software

- RAD Key [WX-010-0005]
- Alibi Reader [WX-010-0114]
- RADWAG Development Studio [WX-010-0104]
- R-Panel [WX-010-0187]
- R-Lab [WX-010-0080]

Device dimensions

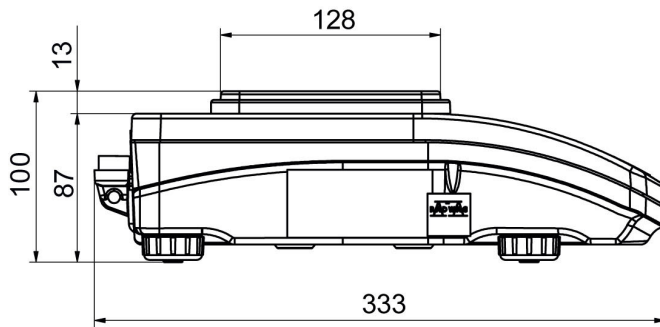

PS R, d = 1mg

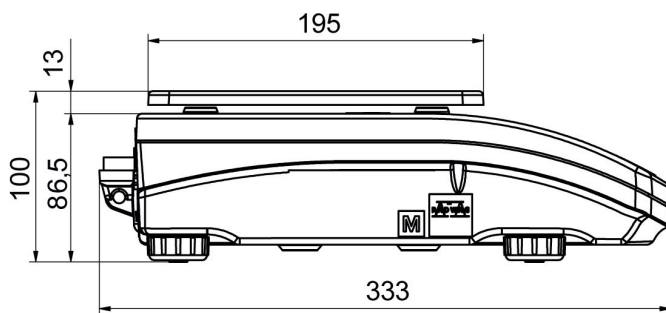

PS R, d = 10 mg

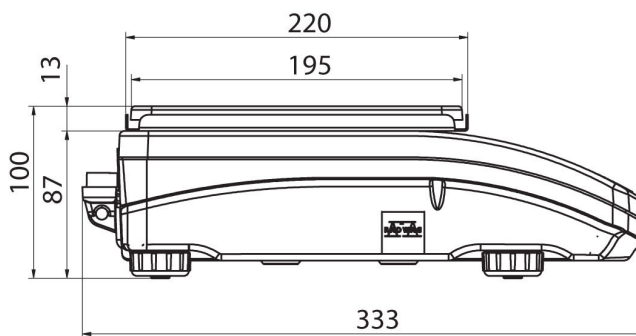
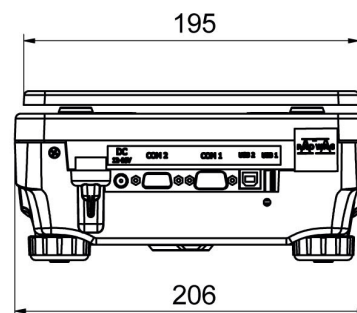

PS R.M, d = 10 mg

