



More information on the website
radwag.com/de/info,w1,GT1

Präzisionswaage PS 3500.R2.M



The drawings, photos and graphics used are for illustrative purposes only.

Funktionen



Autotest



Dosing



Percent Weighing



Totalizing



Parts counting



Peak hold



Newton unit measurement



Statistics



Checkweighing



Under-pan weighing



GLP Procedures



Animal weighing



Density determination

Technische Daten

Messtechnische Parameter	
Wägebereich [Max]	3500 g
Min. Belastung	500 mg
Ziffernschritt [d]	10 mg
Eichwert [e]	100 mg
Tarierbereich	-3500 g
Standard Wiederholbarkeit [5% Max]	5 mg

Messtechnische Parameter	
Standard Wiederholbarkeit [Max]	8 mg
Min. Einwaage (USP)	10 g
Min. Einwaage (U=1%, k=2)	1 g
Linearität	±20 mg
Stabilisierungszeit	1,5 s
Justierung	intern (automatisch)
OIML-Klasse	II
Empfindlichkeitsdrift Temperatur	$2 \times 10^{-6} / ^\circ\text{C} \times \text{Rt}$
Physikalische Parameter	
Nivelliersystem	manuell
Display	LCD (hinterleuchtet)
Lieferumfang	Waage, Waagschale, Waagschalenabdeckung, Netzteil
Waagschale	195×195 mm
Verpackungsgröße	475×380×345 mm
Nettogewicht	4,33 kg
Bruttogewicht	5,5 kg
Konstruktion	
Schutzart	IP 43
Kommunikationsschnittstellen	
Schnittstellen	2×RS232 ¹ , USB-A, USB-B, Wi-Fi (optional)
Elektrische Parameter	
Stromversorgung	Adapter: 100 – 240V AC 50/60Hz 0,6A; 12V DC 1,2A Waage: 12 – 15V DC 0,4A max
Leistungsaufnahme des Geräts	4 W
Umgebungsbedingungen	
Umgebungstemperatur	+10 – +40 °C
Relative Luftfeuchtigkeit	40% – 80%

Wiederholbarkeit wird als Standardabweichung von 10 Wägezyklen ausgedrückt.

Die Stabilisierungszeit ist abhängig von den Umgebungsbedingungen und der Geschwindigkeit bei Auflegen der Last auf der Waagschale; für FAST-Profil definiert.

¹ Die als Zubehör erhältlichen Barcode-Scanner arbeiten mit der Waage nur über die RS232-Schnittstelle.

* Wi-Fi® is a registered trademark of Wi-Fi® Alliance.



Extra payment for verification



Zubehör

Waagenkoffer
 Antivibrationstische
 Netzteile
 Anschlusskabel für Zigarettanzünder
 USB-Kabel (Waage – Drucker)
 Barcode-Scanner
 Kabel RS 232, RS 485

Displays
 Dichtebestimmungsset
 Thermische Drucker
 Kabel RS 232, RS 485
 Schutzhauben
 Unterflurwägung
 Kabel RS 232 (Waage – Drucker)

Software

- RAD Key [WX-010-0005]
- Alibi Reader [WX-010-0114]
- RADWAG Development Studio [WX-010-0104]

- R Panel [WX-010-0187]
- RLAB [WX-010-0080]

Abmessungen des Geräts

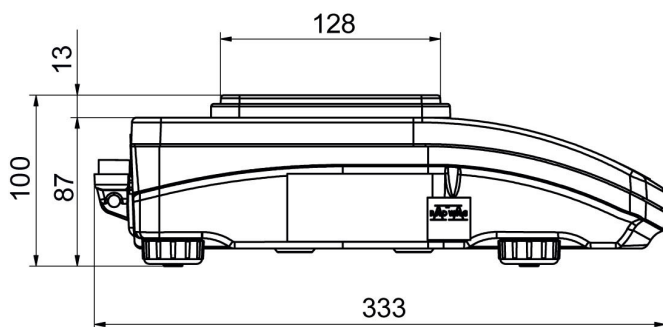

PS R, d = 1mg

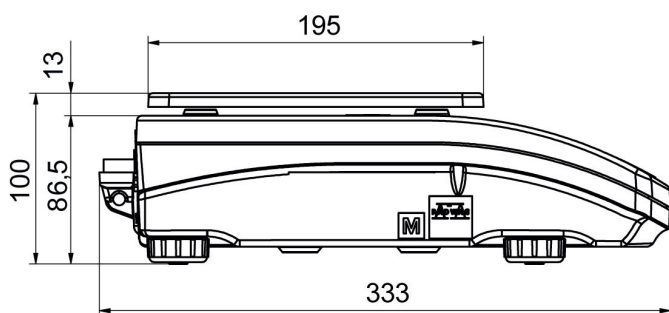
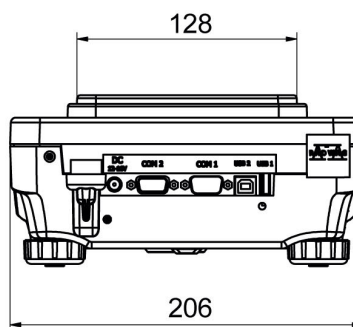

PS R, d = 10 mg

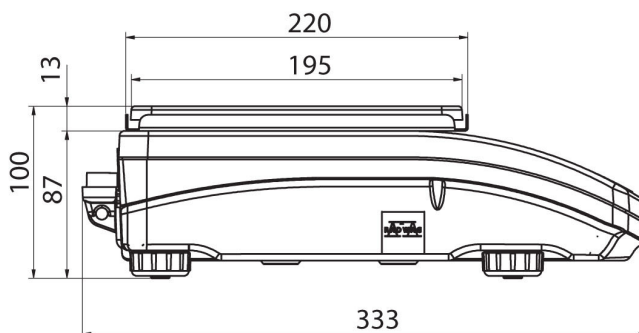
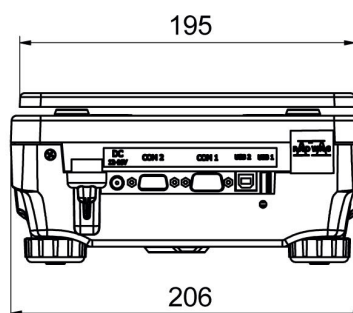

PS R.M, d = 10 mg

