



More information on the website
radwag.com/en/info,w1,GNN

WAY 5.5Y.KO Mass Comparator



The drawings, photos and graphics used are for illustrative purposes only.

Datasheet

Metrological parameters	
E1 Calibration Range	2 – 5 kg
E2 Calibration Range	500 g – 5 kg
F1 Calibration Range	200 g – 5 kg
F2 Calibration Range	20 g – 5 kg
M1 Calibration Range	1 g – 5 kg
M2 Calibration Range	1 g – 5 kg
Maximum capacity [Max]	5.05 kg
Readability [d]	0.1 mg
Standard repeatability [5% Max]	0.15 mg
Standard repeatability [Max]	0.2 mg
Permissible repeatability	0.35 mg
Eccentricity (tested load)	0 mg*
Electric compensation range	-10 g – +50 g
Stabilization time	20 s
Adjustment	internal

Physical parameters	
Display	10" graphic colour touchscreen
Weighing pan dimensions	ø90 mm
Weighing device dimensions	385×217×545 mm
Controlling device dimensions	249×170×72 mm
Anti-draft chamber dimensions	560×340×570 mm
Packaging dimensions	945×820×1260 mm
Chamber packaging size	820×850×630 mm
Net weight	39 kg
Gross weight	59 kg
Supplementary weights internal	automatic
Supplementary weights external	500 g, 300 g, 100 g, 50 g, 30 g, 2×10 g
Communication interface	
Communication interface	2×USB-A, USB-C, HDMI, Ethernet, Wi-Fi, Hotspot
Environmental conditions	
Operating temperature	+15 – +30 °C
Operating temperature change rate	±0.5 °C / 12 h (±0.3 °C / 4 h)
Relative humidity	40% – 60%
Relative humidity change rate	±5% / 4 h

Repeatability is expressed as a standard deviation determined for 6 ABBA cycles. Standard deviation is experimentally determined under ambient conditions for calibration of E1 class mass standards specified in OIML R111 (Table C.1.) document.

Eccentricity (tested load) – suspended self-centring weighing pan (available as an option): 0 mg.

* **Eccentricity (tested load):** 1 d / mm.

* Wi-Fi® is a registered trademark of Wi-Fi® Alliance.



Accessories

RFID Tags
 Antivibration Tables
 Additional modules
 Protective cover for balances
 Barcode scanners
 RS 232, RS 485 cables
 Label Printers

THBR 2.0 System - Ambient Conditions Monitoring
 Receipt Printer
 Suspended Self-Centring Weighing Pan for WAY 5Y.KO Manual Mass Comparator
 Fingerprint Reader
 RS 232, RS 485 cables
 RS 232 cables (scale - printer)

Software

• RAD Key [WX-010-0005]
 • RMCS System Network Management of Calibration Process [WX-010-0048]

• RMCS Lite [WX-010-0164]

Device dimensions



WAY 5.5Y.KO

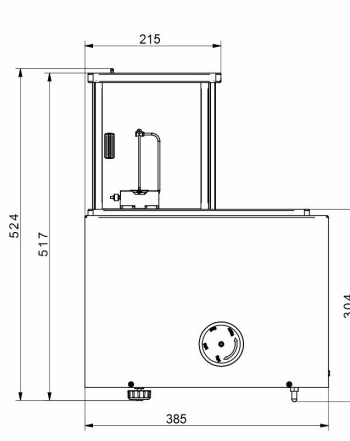
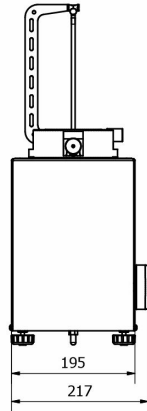

WAY 100.5Y.KO

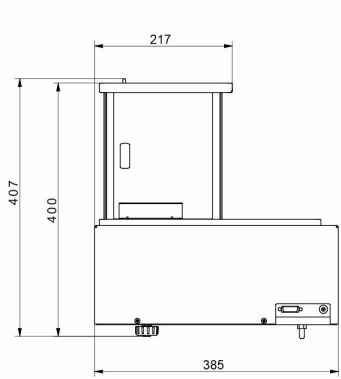
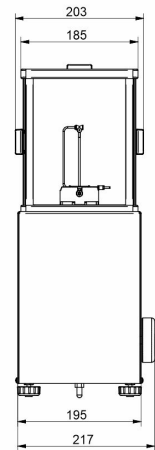

WAY 1200.5Y.KO

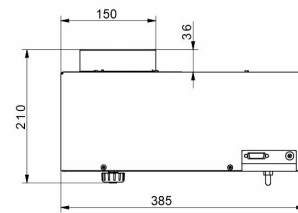
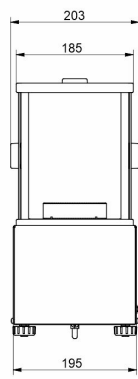

WAY 5100.5Y.KO

