



More information on the website
radwag.com/us/info,w1,FV9

PS 600.R2 Precision Balance



The drawings, photos and graphics used are for illustrative purposes only.

Functions

-  Autotest
-  Dosing
-  Percent Weighing
-  Totalizing
-  Parts counting
-  Peak hold
-  Newton unit measurement
-  Statistics
-  Checkweighing
-  Under-pan weighing
-  GLP Procedures
-  Animal weighing
-  Density determination

Datasheet

Maximum capacity [Max]	600 g
Minimum load	20 mg
Readability [d]	1 mg
Verification unit [e]	10 mg
Tare range	-600 g
Standard repeatability [5% Max]	0,5 mg

Standard repeatability [Max]	1,5 mg
Standard minimum weight (USP)	1 g
Standard minimum weight (U=1%, k=2)	0,1 g
Linearity	±3 mg
Stabilization time	2 s
Adjustment	internal (automatic)
OIML Class	II
Sensitivity temperature drift	$2 \times 10^{-6} / ^\circ\text{C} \times \text{Rt}$
Physical parameters	
Leveling system	manual
Display	LCD (backlit)
Delivery components	Balance, weighing pan, weighing pan shield, grounding bumper ×1, bumper ×3, power supply.
Weighing pan dimensions	128×128 mm
Packaging dimensions	475×380×345 mm
Net weight	3,9 kg
Gross weight	5 kg
Construction	
Protection class	IP 43
Communication interface	2×RS232 ¹ , USB-A, USB-B, Wi-Fi (option)
Power supply	Adapter: 100 – 240V AC 50/60Hz 0,6A; 12V DC 1,2A Balance: 12 – 15V DC 0,4A max
Power consumption	4 W
Operating temperature	+10 ÷ +40 °C
Relative humidity	40% ÷ 80%

* Wi-Fi® is a registered trademark of Wi-Fi® Alliance.



Extra payment for verification



Accessories

!Balance Storage Case
 Antivibration tables
 Power Adapters
 Cigarette lighter receptacle power supply cables
 USB cable (scale - printer)
 Density determination KIT
 Barcode scanners
 Anti-draft Chamber for balances with a weighing pan 128×128mm

RS 232, RS 485 cables
 Displays
 Draft Shield
 Receipt Printer
 Protective cover for balances
 RS 232, RS 485 cables
 Under-pan weighing
 RS 232 cables (scale - printer)

Software

• RAD Key [WX-010-0005]
 • Alibi Reader PC Software [WX-010-0114]

• R Panel [WX-010-0187]
 • RADWAG Development Studio [WX-010-0104]

Device dimensions

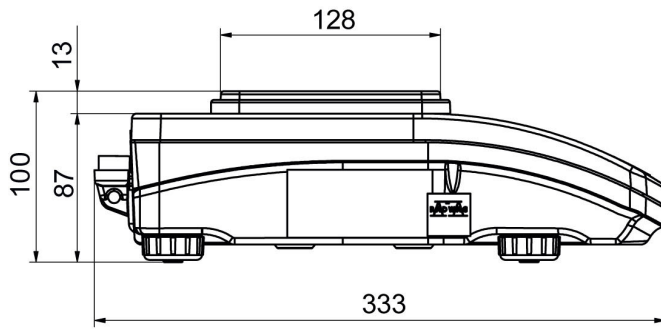

PS R, d = 1mg

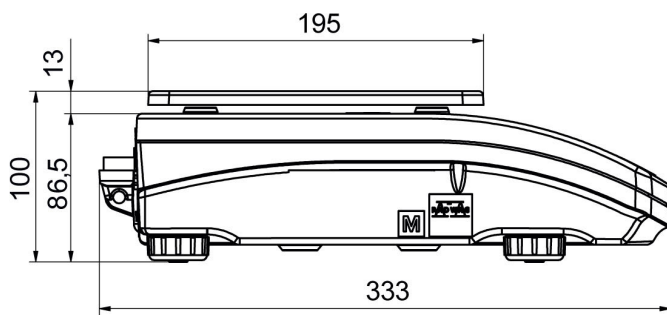
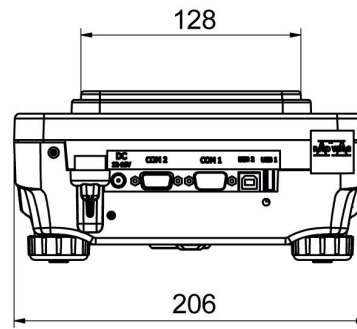

PS R, d = 10 mg

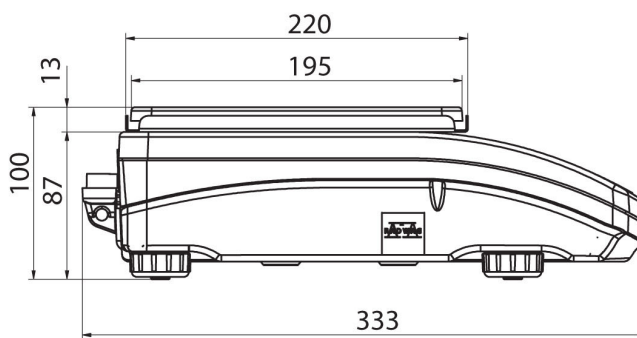
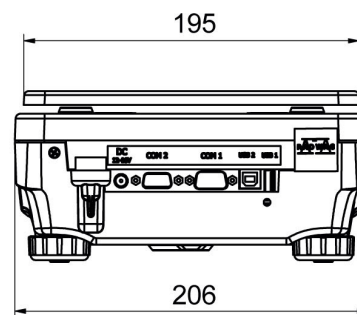

PS R.M, d = 10 mg

