



More information on the website
radwag.com/us/info,w1,FDD

H315.4.300/600.H6/Z Stainless Steel Platform Scale, pit version



The drawings, photos and graphics used are for illustrative purposes only.

Functions

 Plus/Minus Control

 Percent Weighing

 Totalizing

 Parts counting

 Internal battery

 Peak hold

 Newton unit measurement

 Animal weighing

Datasheet

Maximum capacity [Max]	300/600 kg
Minimum load	2 kg
Readability [d]	100/200 g
Tare range	-600 kg
OIML Class	III
Physical parameters	
Display	LCD (backlit)
Weighing pan dimensions	800×800 mm
Weighing platform height	88 mm

Physical parameters	
Packaging dimensions	1000×1000×530 mm
Scale mass with indicator and frame	75 kg
Cable length	3 m
Construction	
Protection class	IP 68 construction, IP 68 (1h max)/69 terminal
Communication interface	RS232, USB
Optional interfaces	RS232 or RS485 or 4IN/4OUT or Ethernet or analog output 4-20 mA
Power supply	100 – 240 V AC 50/60 Hz
Optional power supply	internal rechargeable battery
Operation time on batteries	max 7h
Operating temperature	-10 ÷ +40 °C
Relative humidity	10% ÷ 85% RH no condensation



Extra payment for verification



Accessories

RS 232 cables (scale - printer)
 Displays
 RS 232 cables (scale - Ethernet)
 RS 232, RS 485 cables
 RS 232 – Ethernet Converter
 USB adapter

Receipt Printer
 USB cable (scale - printer)
 Stands, wall mounting kits and mounting brackets
 RS 232 – USB Converter
 RS 232, RS 485 cables

Software

- RAD Key [WX-010-0005]
- Scale Editor - EWAG 2.1 [WX-010-0173]

- R Panel [WX-010-0187]

Device dimensions

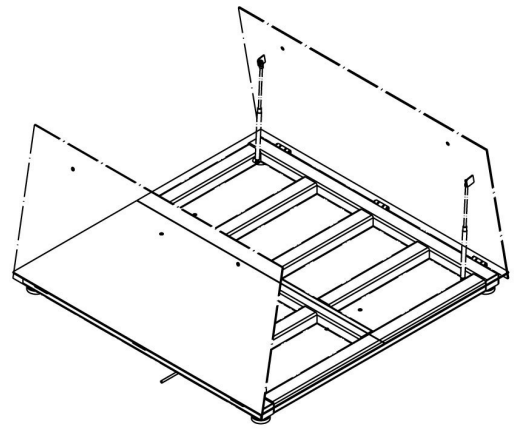

Single-leaf platform:

H315.4.H6/Z

H315.4.H7/Z

H315.4.H8/Z

Double-leaf platform:

H315.4.H8/9/Z

H315.4.H9/Z

H315.4.H10/Z



Scale type	A	B	H
H315.4.150-600.H6/Z	800	800	88±2
H315.4.150-1500.H7/Z	1000	1000	88±2
H315.4.300-1500.H8/Z	1200	1200	88 ±2
H315.4.3000.H8/Z	1200	1200	111 ±2
H315.4.300-1500.H8/9/Z	1200	1500	88 ±2
H315.4.3000.H8/9/Z	1200	1500	111 ±2
H315.4.300-1500.H9/Z	1500	1500	88 ±2
H315.4.3000-6000.H9/Z	1500	1500	111 ±2
H315.4.600-6000.H10/Z	1500	2000	111 ±2

dimensions in mm