



More information on the website
radwag.com/de/info,w1,EVT

Präzisionswaage PS 3500.R1.M



The drawings, photos and graphics used are for illustrative purposes only.

Funktionen



Autotest



Dosing



Percent Weighing



Totalizing



Parts counting



Peak hold



Newton unit measurement



Statistics



Checkweighing



GLP Procedures



Animal weighing



Density determination

Technische Daten

Messtechnische Parameter	
Wägebereich [Max]	3500 g
Min. Belastung	500 mg
Zifferschritt [d]	0,01 g
Tarierbereich	-3500 g
Wiederholbarkeit (Max)	0,008 g
Wiederholbarkeit (5% Max)	0,005 g
Linearität	±0,02 g

Messtechnische Parameter	
Stabilisierungszeit	1,5 s
Justierung	extern
Empfindlichkeitsdrift Temperatur	$2 \times 10^{-6} / ^\circ\text{C} \times \text{Rt}$
Physikalische Parameter	
Nivelliersystem	manualny
Display	LCD (hinterleuchtet)
Lieferumfang	Waage, Waagschale, Waagschalenabdeckung, Netzteil
Waagschale	195×195 mm
Verpackungsgröße	475×380×345 mm
Nettogewicht	3,6 kg
Bruttogewicht	5,1 kg
Konstruktion	
Schutzart	IP 43
Kommunikationsschnittstellen	
Schnittstellen	2×RS232 ¹ , USB-A, USB-B, Wi-Fi (optional)
Elektrische Parameter	
Stromversorgung	Adapter: 100 – 240V AC 50/60Hz 0,6A; 12V DC 1,2A Waage: 12 – 15V DC 0,4A max
Leistungsaufnahme des Geräts	4 W
Umgebungsbedingungen	
Umgebungstemperatur	+10 ÷ +40 °C
Relative Luftfeuchtigkeit	40% ÷ 80%

Wiederholbarkeit wird als Standardabweichung von 10 Wägezyklen ausgedrückt.

Die Stabilisierungszeit ist abhängig von den Umgebungsbedingungen und der Geschwindigkeit bei Auflegen der Last auf der Waagschale; für FAST-Profil definiert.

¹ Barcode scanner, available as weighing instrument accessory, communicate with the instrument via RS232 interface exclusively.

* Wi-Fi® is a registered trademark of Wi-Fi® Alliance.



Zubehör

Waagenkoffer
 Antivibrationstische
 Netzteile
 Anschlusskabel für Zigarettenanzünder
 USB-Kabel (Waage – Drucker)
 Barcodescanner
 Kabel RS 232, RS 485

Displays
 Dichtebestimmungsset
 Thermische Drucker
 Kabel RS 232, RS 485
 Schutzhauben
 Unterflurwägung
 Kabel RS 232 (Waage – Drucker)

Software

• RAD Key [WX-010-0005]
 • Alibi Reader [WX-010-0114]

• R Panel [WX-010-0187]
 • RLAB [WX-010-0080]

Abmessungen des Geräts

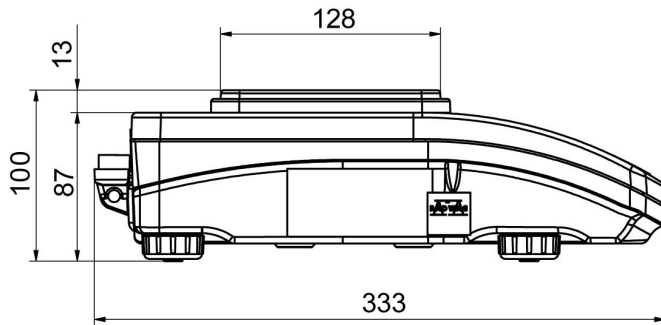

PS R, d = 1 mg

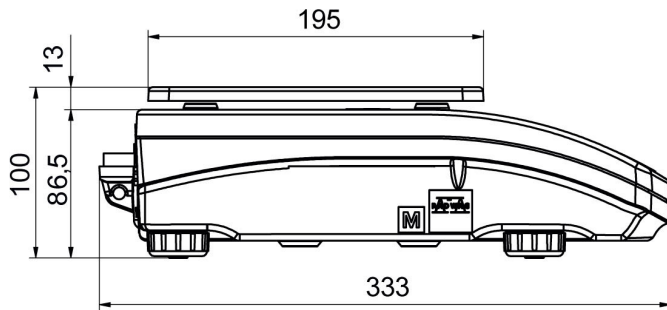
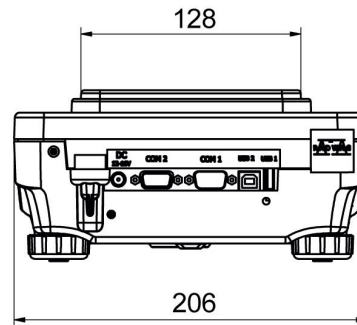

PS R, d = 10 mg

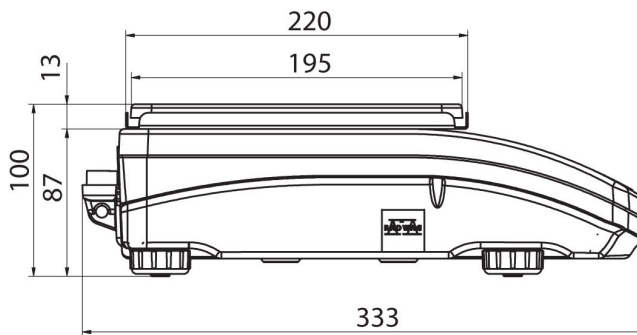
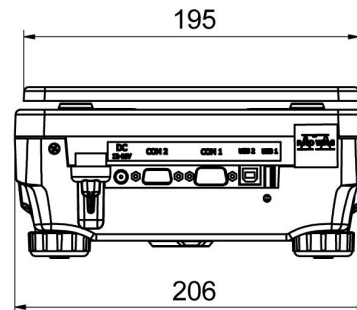

PS R.M, d = 10 mg

