



More information on the website  
radwag.com/de/info,w1,EVT

# Präzisionswaage PS 3500.R1.M



The drawings, photos and graphics used are for illustrative purposes only.

## Funktionen

-  Autotest
-  Dosing
-  Percent Weighing
-  Totalizing
-  Parts counting
-  Peak hold
-  Newton unit measurement
-  Statistics
-  Checkweighing
-  Under-pan weighing
-  GLP Procedures
-  Animal weighing
-  Density determination

## Technische Daten

Messtechnische Parameter	
Wägebereich [Max]	3500 g
Min. Belastung	500 mg
Zifferschritt [d]	0,01 g
Tarierbereich	-3500 g
Wiederholbarkeit (Max)	0,008 g
Wiederholbarkeit (5% Max)	0,005 g

Messtechnische Parameter	
Linearität	±0,02 g
Stabilisierungszeit	1,5 s
Justierung	extern
Empfindlichkeitsdrift Temperatur	$2 \times 10^{-6} / ^\circ\text{C} \times \text{Rt}$
Physikalische Parameter	
Nivelliersystem	manuell
Display	LCD (hinterleuchtet)
Lieferumfang	Waage, Waagschale, Waagschalenabdeckung, Netzteil
Waagschale	195×195 mm
Verpackungsgröße	475×380×345 mm
Nettogewicht	3,6 kg
Bruttogewicht	5,1 kg
Konstruktion	
Schutzart	IP 43
Kommunikationsschnittstellen	
Schnittstellen	2×RS232 <sup>1</sup> , USB-A, USB-B, Wi-Fi (optional)
Elektrische Parameter	
Stromversorgung	Adapter: 100 – 240V AC 50/60Hz 0,6A; 12V DC 1,2A Waage: 12 – 15V DC 0,4A max
Leistungsaufnahme des Geräts	4 W
Umgebungsbedingungen	
Umgebungstemperatur	+10 – +40 °C
Relative Luftfeuchtigkeit	40% – 80%

**Wiederholbarkeit** wird als Standardabweichung von 10 Wägezyklen ausgedrückt.

**Die Stabilisierungszeit** ist abhängig von den Umgebungsbedingungen und der Geschwindigkeit bei Auflegen der Last auf der Waagschale; für FAST-Profil definiert.

<sup>1</sup> Die als Zubehör erhältlichen Barcode-Scanner arbeiten mit der Waage nur über die RS232-Schnittstelle.

\* Wi-Fi® is a registered trademark of Wi-Fi® Alliance.



## Zubehör

Waagenkoffer  
 Antivibrationstische  
 Netzteile  
 Anschlusskabel für Zigarettenanzünder  
 USB-Kabel (Waage – Drucker)  
 Barcode-Scanner  
 Kabel RS 232, RS 485

Displays  
 Dichtebestimmungsset  
 Thermische Drucker  
 Kabel RS 232, RS 485  
 Schutzhauben  
 Unterflurwägung  
 Kabel RS 232 (Waage – Drucker)

## Software

• RAD Key [WX-010-0005]  
 • Alibi Reader [WX-010-0114]

• R Panel [WX-010-0187]  
 • RLAB [WX-010-0080]

# Abmessungen des Gerats

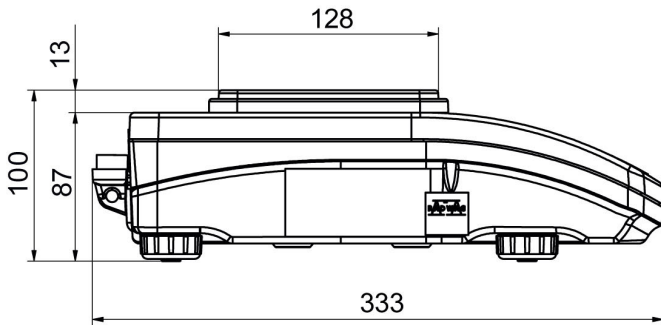

PS R, d = 1 mg

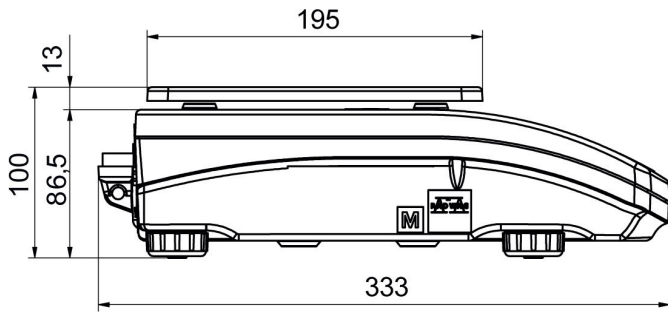
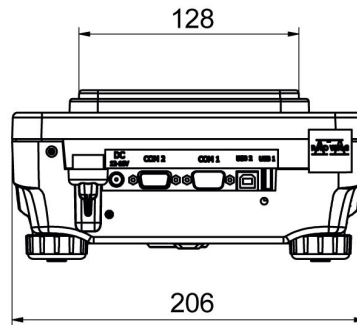

PS R, d = 10 mg

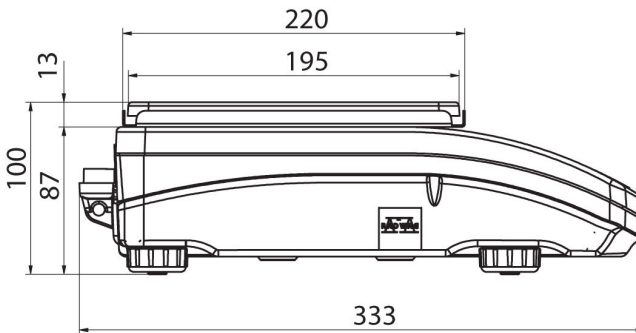
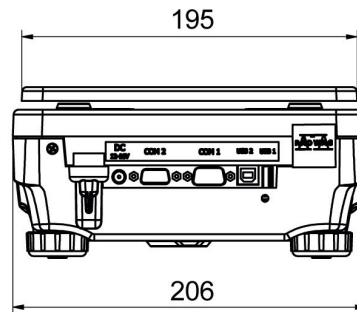

PS R.M, d = 10 mg

